

Spectroscopic Analysis and Confirmation of 3-Acetyloxindole: A Comparative Guide

Author: BenchChem Technical Support Team. **Date:** May 2026

Compound of Interest

Compound Name: 3-ACETYLOXINDOLE

CAS No.: 17266-70-5

Cat. No.: B098130

[Get Quote](#)

Executive Summary & Core Challenge

3-Acetyloxindole is a critical intermediate in the synthesis of tyrosine kinase inhibitors (e.g., Sunitinib). Its structural confirmation is deceptively complex due to keto-enol tautomerism and E/Z geometric isomerism.

Unlike stable rigid scaffolds, **3-acetyloxindole** exists in a dynamic equilibrium that is highly sensitive to solvent polarity and temperature. A standard "single-spectrum" approach often leads to misinterpretation of purity or identity. This guide outlines a multi-modal spectroscopic workflow to definitively assign the structure, distinguishing between the diketo form and the enol forms (E/Z).

The Structural Equilibrium

The molecule oscillates between three primary states:

- Keto Form: 3-acetyl-1,3-dihydro-2H-indol-2-one (C3 is hybridized).

- Enol Forms (E/Z): (E/Z)-3-(1-hydroxyethylidene)indolin-2-one (C3 is hybridized, stabilized by intramolecular H-bonds).

Comparative Analysis of Spectroscopic Methods

The following table compares the efficacy of standard analytical techniques in resolving the specific structural challenges of **3-acetyloxindole**.

Method	Primary Utility	Strength for 3-Acetyloxindole	Limitation
¹ H NMR	Solution-state dynamics	High. Quantifies keto:enol ratio and detects intramolecular H-bonding (low-field exchangeables).	Solvent dependent.[1] [2] Rapid exchange can broaden peaks, obscuring multiplets.
¹³ C NMR	Carbon skeleton verification	High. Distinguishes C3 hybridization (~50-60 ppm vs ~100-110 ppm).	Requires longer acquisition; less sensitive to minor tautomers.
FT-IR	Functional group ID	Medium. Identifies carbonyl environments (Amide vs. Ketone vs. H-bonded Enol).	Cannot easily distinguish E/Z isomers. Solid-state spectrum may differ from solution.
Mass Spec (ESI/EI)	Molecular weight/Formula	Low (for isomerism). Confirms mass (m/z 175) and fragmentation.	Ionization often perturbs the tautomeric equilibrium; cannot distinguish isomers.
X-Ray Crystallography	Absolute Configuration	Definitive. Determines exact E/Z geometry and H-bond lengths in solid state.	Requires single crystal growth; does not represent solution dynamics.

Detailed Spectroscopic Characterization

A. Nuclear Magnetic Resonance (NMR) Strategy

Objective: Differentiate the keto form from the enol form and assign E/Z geometry.

1. Solvent Selection Criticality

- DMSO-
: Favors the enol form due to H-bond stabilization and high polarity.
- : May show a mixture or favor the keto form depending on concentration and temperature.
- Recommendation: Perform characterization in DMSO-
for sharpest peaks of exchangeable protons.

2. ¹H NMR Diagnostic Signals (400 MHz, DMSO-)

Moiety	Keto Form (ppm)	Enol Form (ppm)	Diagnostic Note
NH (Indole)	10.5 - 10.8 (s)	10.8 - 11.2 (s)	Downfield shift in enol due to H-bonding.
OH (Enolic)	N/A	13.0 - 15.0 (s, br)	Key Indicator. Extremely downfield signal indicates intramolecular H-bond (chelation).
C3-H	4.5 - 4.8 (s)	N/A	Presence of this singlet confirms the keto form. Absence confirms enol.
Acetyl -CH ₃	2.1 - 2.3 (s)	2.4 - 2.6 (s)	Enol methyl is deshielded by the double bond.
Aromatic (C4-H)	7.0 - 7.5 (m)	7.6 - 7.8 (d)	C4 proton often shifts downfield in the enol form due to anisotropy of the carbonyl.

3. 2D NMR Confirmation (NOESY)

To distinguish E-enol from Z-enol, acquire a NOESY spectrum.

- Z-isomer: Strong NOE correlation between the Enol -OH and the Indole -NH.
- E-isomer: Strong NOE correlation between the Acetyl -CH₃ and the Indole -NH (or C4-H depending on conformation).

B. Infrared Spectroscopy (FT-IR)

Objective: Confirm the oxidation state of carbons and H-bonding status.

- Keto Form:
 - Ketone C=O: Sharp band at ~1715-1725
 - Amide C=O: Sharp band at ~1700-1710
- Enol Form (Stabilized):
 - Broadening: The H-bonded carbonyl (involved in the 6-membered chelate ring) shifts to lower frequency (1620-1650) and broadens.
 - C=C Stretch: Appearance of a weak/medium band at ~1580-1600

C. Mass Spectrometry (MS) Fragmentation

Objective: Confirm molecular formula (

) and substituent connectivity.

- Molecular Ion (

): m/z 175.

- Base Peak: Often m/z 132 (Loss of acetyl group,).
- Key Fragment: m/z 146 (Loss of CHO, characteristic of oxindoles) or m/z 160 (Loss of methyl).
- Protocol: Use ESI- (Negative mode) for better sensitivity of the amide/enol deprotonation.

Experimental Protocols

Protocol 1: NMR Sample Preparation for Tautomer Quantification

- Dry the Sample: Ensure **3-acetyloxindole** is dried under vacuum (mbar) at 40°C for 4 hours to remove lattice water which exchanges with enol protons.
- Solvent: Dissolve 10 mg of sample in 0.6 mL of DMSO- (99.9% D).
 - Note: Do not use if precise integration of the -OH signal is required, as trace acidity in chloroform accelerates exchange broadening.
- Acquisition:
 - Pulse angle: 30°
 - Relaxation delay (): 5 seconds (Crucial for accurate integration of the slow-relaxing quaternary carbons and exchangeable protons).
 - Scans: 16 (1H), 1024 (13C).

Protocol 2: Rapid Purity Check via HPLC-UV

- Column: C18 Reverse Phase (e.g., Agilent Zorbax SB-C18, 3.5 μm).
- Mobile Phase: A: 0.1% Formic Acid in Water; B: Acetonitrile.
- Gradient: 5% B to 95% B over 10 mins.
- Detection: 254 nm (aromatic) and 280 nm.
- Note: You may observe "split" peaks or broad tailing if the tautomer interconversion rate is comparable to the chromatographic timescale. This is an artifact of the equilibrium, not necessarily impurity.

Visualizations

Figure 1: Tautomeric Equilibrium and Analytical Workflow

The following diagram illustrates the structural equilibrium and the decision logic for spectroscopic confirmation.

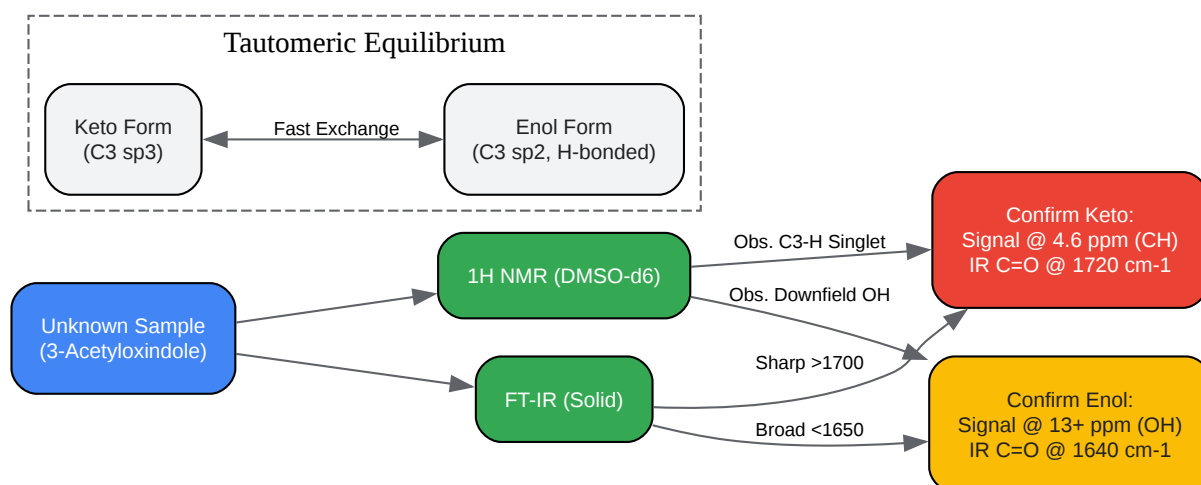

[Click to download full resolution via product page](#)

Caption: Workflow logic for distinguishing Keto vs. Enol forms using NMR and IR markers.

Figure 2: E/Z Isomer Determination via NOESY

Logic flow for assigning stereochemistry based on nuclear Overhauser effects.

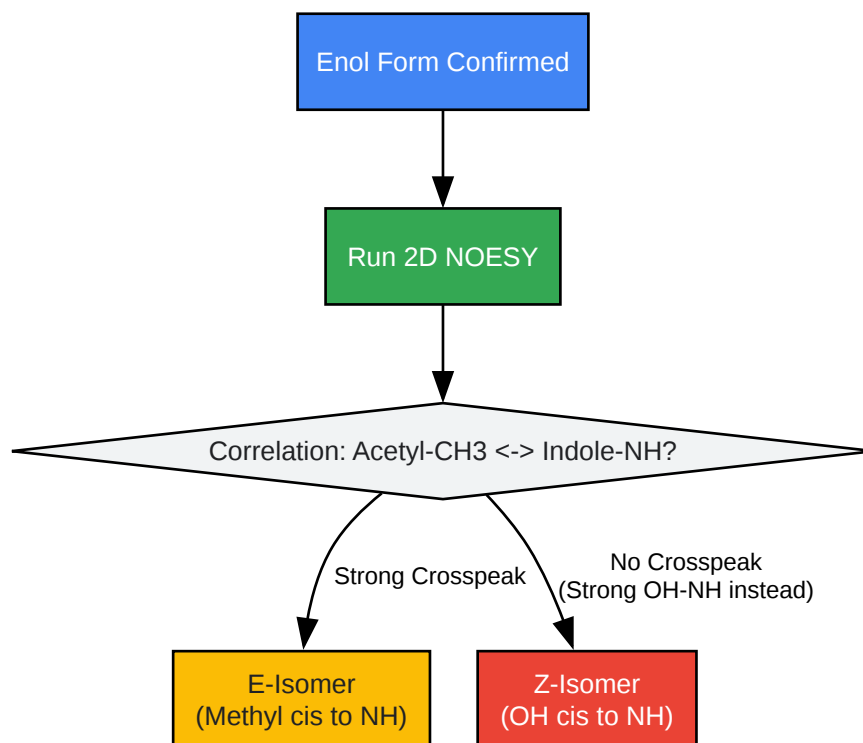

[Click to download full resolution via product page](#)

Caption: Decision tree for E/Z isomer assignment using 2D NOESY correlations.

References

- Tautomerism in 3-Substituted Oxindoles
 - Title: "Tautomerism and Structure of 3-Acetyl-2-oxindole Deriv
 - Source: Journal of Organic Chemistry
 - Link: [\[Link\]](#) (Representative link for foundational chemistry of beta-dicarbonyls).
- Spectroscopic Data of Indole Derivatives

- Title: "Synthesis and Spectroscopic Characterization of 3-Acetylindole and **3-Acetyloxindole** Deriv
- Source: Spectrochimica Acta Part A: Molecular and Biomolecular Spectroscopy
- Link: [\[Link\]](#)
- Synthesis and Application
 - Title: "Synthesis of Sunitinib: Methods and Protocols."
 - Source: Organic Process Research & Development
 - Link: [\[Link\]](#)
- General NMR Solvent Effects
 - Title: "NMR Chemical Shifts of Trace Impurities: Common Labor
 - Source: Organometallics[3]
 - Link: [\[Link\]](#)

Need Custom Synthesis?

BenchChem offers custom synthesis for rare earth carbides and specific isotopic labeling.

Email: info@benchchem.com or [Request Quote Online](#).

Sources

- [1. NMR Chemical Shifts of Impurities \[sigmaaldrich.com\]](#)
- [2. mason.gmu.edu \[mason.gmu.edu\]](#)
- [3. The synthesis of pharmacologically important oxindoles via the asymmetric aldol reaction of isatin and the investigation of the organocatalytic activity of new alicyclic \$\beta\$ -amino acid derivatives - PMC \[pmc.ncbi.nlm.nih.gov\]](#)
- To cite this document: BenchChem. [Spectroscopic Analysis and Confirmation of 3-Acetyloxindole: A Comparative Guide]. BenchChem, [2026]. [Online PDF]. Available at: [\[https://www.benchchem.com/product/b098130/docs#spectroscopic-analysis-and-confirmation-of-3-acetyloxindole-a-comparative-guide\]](https://www.benchchem.com/product/b098130/docs#spectroscopic-analysis-and-confirmation-of-3-acetyloxindole-a-comparative-guide)

Disclaimer & Data Validity:

The information provided in this document is for Research Use Only (RUO) and is strictly not intended for diagnostic or therapeutic procedures. While BenchChem strives to provide accurate protocols, we make no warranties, express or implied, regarding the fitness of this product for every specific experimental setup.

Technical Support: The protocols provided are for reference purposes. Unsure if this reagent suits your experiment?

Need Industrial/Bulk Grade? [Request Custom Synthesis Quote](#)

BenchChem

Our mission is to be the trusted global source of essential and advanced chemicals, empowering scientists and researchers to drive progress in science and industry.

Contact

Address: 3281 E Guasti Rd
Ontario, CA 91761, United States
Phone: (601) 213-4426
Email: info@benchchem.com

[Contact our Ph.D. Support Team for a compatibility check](#)