

Introduction: Strategic Importance and Synthesis Overview

Author: BenchChem Technical Support Team. **Date:** May 2026

Compound of Interest

Compound Name: 3-Bromo-5-methylphenol

CAS No.: 74204-00-5

Cat. No.: B1280546

[Get Quote](#)

3-Bromo-5-methylphenol is a crucial building block in organic synthesis, valued for its specific substitution pattern that allows for further functionalization in the development of complex molecules.^{[1][2][3]} Its applications span the creation of active pharmaceutical ingredients (APIs) and potent agrochemicals.^{[3][4]} This document provides a comprehensive guide to its large-scale synthesis, moving beyond a simple recitation of steps to explain the underlying chemical principles and process controls necessary for a safe, efficient, and scalable operation.

The primary challenge in synthesizing this molecule is achieving high regioselectivity. Direct bromination of the readily available precursor, m-cresol (3-methylphenol), often leads to a mixture of ortho- and para-brominated isomers, as well as di- and tri-brominated byproducts, which are difficult and costly to separate at scale.^{[5][6]} To overcome this, we will detail a robust and highly selective protocol based on the Sandmeyer reaction, a cornerstone of aromatic chemistry for converting aryl amines into aryl halides with exceptional control.^{[7][8]}

Table 1: Physicochemical Properties of **3-Bromo-5-methylphenol**

Property	Value	Source
CAS Number	74204-00-5	[1][9]
Molecular Formula	C ₇ H ₇ BrO	[1][3][10]
Molecular Weight	187.03 g/mol	[3][4][10]
Appearance	Colorless to off-white crystalline solid	[1]
Melting Point	61-62 °C	[3]
Boiling Point	249 °C at 760 mmHg	[3]
Solubility	Soluble in alcohols, ethers, and chlorinated solvents; slightly soluble in water.	[1]

Recommended Synthetic Pathway: The Sandmeyer Reaction

The Sandmeyer reaction provides a reliable method for introducing a bromine atom at a specific position on the aromatic ring by converting a primary aromatic amine to a diazonium salt, which is then displaced by a bromide ion using a copper(I) salt catalyst.[7][11] This multi-step process ensures high regioselectivity, which is paramount for industrial-scale production where purity and yield are critical economic drivers.

The overall workflow involves two key transformations:

- **Diazotization:** The conversion of the aromatic amine precursor (5-amino-m-cresol) into a diazonium salt using nitrous acid at low temperatures.
- **Bromo-dediazotiation:** The copper(I) bromide-catalyzed displacement of the diazonium group with a bromide, releasing nitrogen gas and forming the desired product.

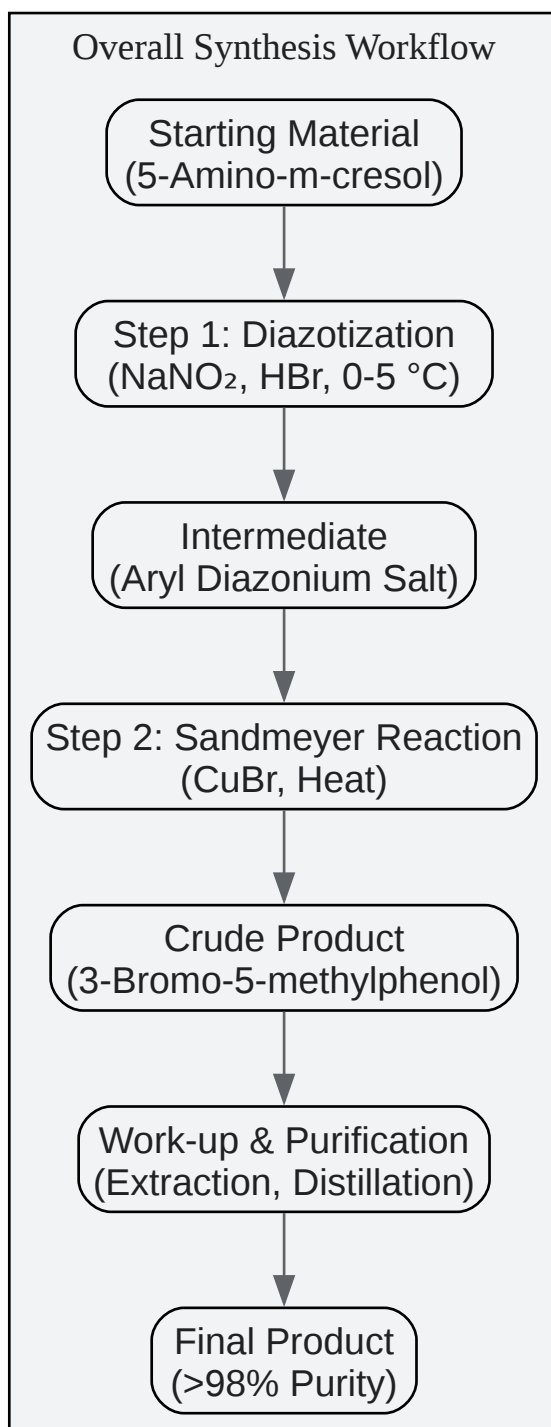

[Click to download full resolution via product page](#)

Caption: High-level workflow for the synthesis of **3-Bromo-5-methylphenol**.

Detailed Large-Scale Synthesis Protocol

This protocol is designed for a nominal 100g scale and can be adapted for larger production volumes with appropriate engineering controls.

Part 1: Diazotization of 5-Amino-m-cresol

Causality: This step converts the stable amino group into a highly reactive diazonium group ($-N_2^+$), an excellent leaving group. The reaction must be conducted at 0-5 °C because diazonium salts are thermally unstable and can decompose violently or undergo unwanted side reactions at higher temperatures. Hydrobromic acid is used both as the acid medium and the source of the bromide counter-ion.

Materials & Equipment:

- Jacketed glass reactor (2 L) with overhead stirring, temperature probe, and addition funnel.
- 5-Amino-m-cresol (123 g, 1.0 mol)
- 48% Hydrobromic acid (HBr) (425 mL, 2.5 mol)
- Sodium nitrite ($NaNO_2$) (72.5 g, 1.05 mol)
- Deionized water
- Ice bath or chiller for the reactor jacket

Procedure:

- **Reactor Setup:** Charge the 2 L jacketed reactor with 48% HBr (425 mL). Begin cooling the reactor jacket to 0 °C.
- **Amine Addition:** Once the acid temperature is below 10 °C, slowly add 5-amino-m-cresol (123 g) with vigorous stirring. The amine will dissolve to form the corresponding ammonium salt. Cool the resulting solution to 0-5 °C.
- **Nitrite Solution Preparation:** In a separate beaker, dissolve sodium nitrite (72.5 g) in 150 mL of deionized water. Cool this solution in an ice bath.

- **Diazotization:** Add the cold sodium nitrite solution dropwise to the stirred amine solution over 60-90 minutes. Crucially, maintain the internal reaction temperature between 0 °C and 5 °C throughout the addition. A slight excess of nitrous acid can be confirmed with starch-iodide paper (turns blue).
- **Holding:** Once the addition is complete, stir the resulting diazonium salt solution for an additional 30 minutes at 0-5 °C. The solution should be kept cold and used immediately in the next step.

Part 2: Sandmeyer Bromo-dediazoniatio

Causality: This is the core transformation where the diazonium group is replaced by bromine. Copper(I) bromide is the catalyst. The mechanism is believed to involve a single-electron transfer from Cu(I) to the diazonium salt, generating an aryl radical, nitrogen gas, and Cu(II)Br. The aryl radical then abstracts a bromine atom from Cu(II)Br to form the product and regenerate the Cu(I) catalyst.^[8] Adding the diazonium salt to a hot CuBr solution helps to control the vigorous evolution of N₂ gas.

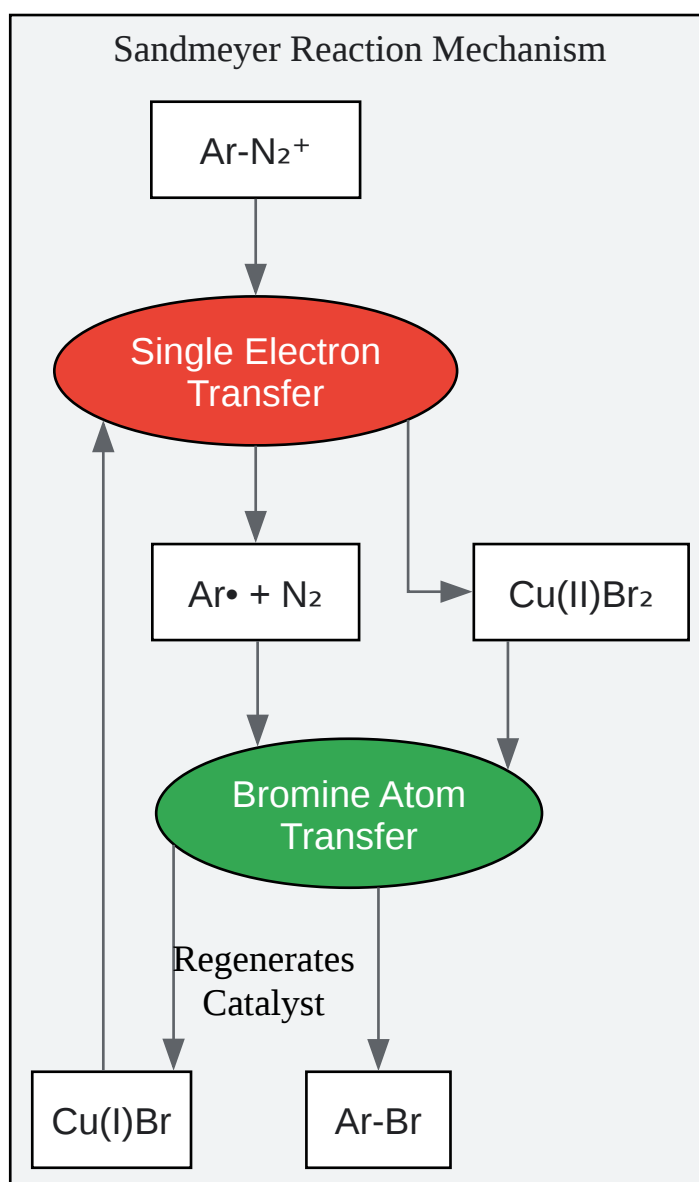

[Click to download full resolution via product page](#)

Caption: Simplified mechanism of the copper(I)-catalyzed Sandmeyer reaction.

Materials & Equipment:

- Jacketed glass reactor (3 L) with overhead stirring, temperature probe, addition funnel, and condenser connected to a gas scrubber.
- Copper(I) bromide (CuBr) (21.5 g, 0.15 mol)

- 48% Hydrobromic acid (HBr) (50 mL)
- Toluene or Dichloromethane (for extraction)
- Sodium hydroxide solution (10%)
- Anhydrous magnesium sulfate or sodium sulfate

Procedure:

- **Catalyst Preparation:** Charge the 3 L reactor with Copper(I) bromide (21.5 g) and 48% HBr (50 mL). Heat the mixture to 60-70 °C with stirring.
- **Addition of Diazonium Salt:** Slowly add the cold diazonium salt solution from Part 1 to the hot CuBr solution over approximately 1-2 hours. A vigorous evolution of nitrogen gas will occur. The rate of addition must be carefully controlled to manage the effervescence and maintain the reaction temperature between 60-80 °C.
- **Reaction Completion:** After the addition is complete, heat the reaction mixture to 90-100 °C for 1 hour to ensure complete decomposition of any remaining diazonium salt.
- **Cooling and Extraction:** Cool the reaction mixture to room temperature. Transfer the mixture to a separatory funnel and extract the product with toluene or dichloromethane (3 x 200 mL).
[2]
- **Washing:** Combine the organic extracts. Wash sequentially with water (200 mL), 10% sodium hydroxide solution (2 x 150 mL) to remove any unreacted phenolic starting material, and finally with brine (150 mL).
- **Drying and Concentration:** Dry the organic layer over anhydrous sodium sulfate, filter, and concentrate the solvent using a rotary evaporator to yield the crude product as an oil or low-melting solid.[2]

Part 3: Purification

Causality: While the Sandmeyer reaction is highly selective, minor impurities may persist.

Vacuum distillation is the preferred method for large-scale purification of liquid or low-melting

point solids, as it allows for separation based on boiling point at temperatures low enough to prevent product degradation.

Equipment:

- Vacuum distillation apparatus.

Procedure:

- Set up the apparatus for vacuum distillation.
- Distill the crude product under reduced pressure. The product, **3-Bromo-5-methylphenol**, will distill at approximately 102-104 °C at 20 mmHg.[12]
- Collect the pure fraction, which should solidify upon cooling.
- The expected yield is 130-150 g (70-80%).

Analytical Quality Control

To ensure the final product meets the required specifications for further use, a suite of analytical tests must be performed.

Table 2: Final Product Specifications

Test	Method	Specification
Appearance	Visual	Colorless to off-white crystalline solid
Purity (Assay)	HPLC/GC	≥ 98.0%
Melting Point	Melting Point Apparatus	61-62 °C
Identity	¹ H NMR, ¹³ C NMR, MS	Conforms to structure
Residual Solvents	GC-HS	As per ICH Q3C guidelines

Safety, Handling, and Environmental Considerations

Large-scale synthesis involving brominating agents and diazonium intermediates requires stringent safety protocols.[13][14]

Table 3: Hazard Analysis and Mitigation

Hazard	Risk	Mitigation and PPE
48% Hydrobromic Acid	Severe corrosive burns to skin and eyes; respiratory tract irritation.	Work in a well-ventilated fume hood. Wear acid-resistant gloves (neoprene/nitrile), chemical splash goggles, a face shield, and a lab coat.[15][16]
Sodium Nitrite	Strong oxidizer, toxic if ingested or inhaled. Can form toxic nitrogen oxides.	Store away from combustible materials. Avoid creating dust. Use standard PPE.
Diazonium Salts	Thermally unstable; can be explosive when isolated and dry.	NEVER isolate the diazonium salt. Keep the solution cold (0-5 °C) at all times and use it immediately after preparation. Use a blast shield for the reactor.
Copper Compounds	Irritant, toxic to aquatic life.	Prevent release to the environment. Dispose of copper-containing waste through a licensed hazardous waste contractor.
Toluene/DCM	Flammable (Toluene), suspected carcinogen (DCM), volatile organic compounds (VOCs).	Use in a well-ventilated area away from ignition sources. Use a closed-system for transfers where possible. Wear appropriate gloves and eye protection.

Emergency Procedures:

- Spills: For HBr spills, neutralize with sodium bicarbonate. For bromine-related spills, a solution of sodium thiosulfate should be readily available.[16]
- Exposure: In case of skin contact, immediately flush with copious amounts of water for at least 15 minutes.[1][17] For eye contact, use an eyewash station and seek immediate medical attention.[15][17]

References

- Practical One-Pot C-H Activation/Borylation/Oxidation: Preparation of **3-Bromo-5-methylphenol** on a Multigram Scale. PubMed.
- phenol, 3-bromo-5-methyl-. ChemBK.
- Bromination safety. YouTube. Available from: [\[Link\]](#)
- Sandmeyer reaction. Wikipedia. Available from: [\[Link\]](#)
- Sandmeyer reaction. L.S.College, Muzaffarpur. Available from: [\[Link\]](#)
- meta cresol on bromination gives. Careers360. Available from: [\[Link\]](#)
- Standard Operating Procedure_Bromine.docx. University of Texas at Dallas. Available from: [\[Link\]](#)
- Handling liquid bromine and preparing bromine water. Royal Society of Chemistry Education. Available from: [\[Link\]](#)
- **3-Bromo-5-methylphenol**. MySkinRecipes. Available from: [\[Link\]](#)
- Recent trends in the chemistry of Sandmeyer reaction: a review. National Institutes of Health (NIH). Available from: [\[Link\]](#)
- Safety Data Sheet: Bromine. Carl ROTH. Available from: [\[Link\]](#)
- ipso Halogenation. 11.' Bromination of phenols, isomerization and disproportionation - of bromophenols, and dienone-phenol rearrangement of bromodienones. Canadian Journal of Chemistry. Available from: [\[Link\]](#)
- Sandmeyer Reaction. Organic Chemistry Portal. Available from: [\[Link\]](#)

- BROMINE BROMINE - Safety Handbook. ICL Group. Available from: [\[Link\]](#)
- Method for selectively brominating phenols. Google Patents.
- **3-bromo-5-methylphenol**. Stenutz. Available from: [\[Link\]](#)
- **3-Bromo-5-methylphenol** | CAS#:74204-00-5. Chemsrvc. Available from: [\[Link\]](#)
- 74204-00-5 | **3-bromo-5-methylphenol**. Alachem Co., Ltd.. Available from: [\[Link\]](#)
- Sandmeyer reaction : r/Chempros. Reddit. Available from: [\[Link\]](#)
- **3-bromo-5-methylphenol**, CAS No. 74204-00-5. iChemical. Available from: [\[Link\]](#)
- **3-Bromo-5-methylphenol** | C7H7BrO | CID 12648409. PubChem. Available from: [\[Link\]](#)
- A Process For Synthesis Of 2 Bromo 4 Methyl Phenol. Quick Company. Available from: [\[Link\]](#)
- 3-bromo-4-hydroxytoluene. Organic Syntheses Procedure. Available from: [\[Link\]](#)

Need Custom Synthesis?

BenchChem offers custom synthesis for rare earth carbides and specific isotopic labeling.

Email: info@benchchem.com or [Request Quote Online](#).

Sources

- 1. chembk.com [chembk.com]
- 2. [3-Bromo-5-methylphenol | 74204-00-5](https://chemicalbook.com) [chemicalbook.com]
- 3. [3-Bromo-5-methylphenol](https://myskinrecipes.com) [myskinrecipes.com]
- 4. [3-Bromo-5-methylphenol | 74204-00-5 | FB67528](https://biosynth.com) | Biosynth [biosynth.com]
- 5. careers360.com [careers360.com]
- 6. [US3449443A - Method for selectively brominating phenols - Google Patents](https://patents.google.com) [patents.google.com]
- 7. [Sandmeyer reaction - Wikipedia](https://en.wikipedia.org) [en.wikipedia.org]

- [8. lscollge.ac.in \[lscollge.ac.in\]](https://lscollge.ac.in)
- [9. chemscene.com \[chemscene.com\]](https://chemscene.com)
- [10. 3-Bromo-5-methylphenol | C7H7BrO | CID 12648409 - PubChem \[pubchem.ncbi.nlm.nih.gov\]](https://pubchem.ncbi.nlm.nih.gov)
- [11. Sandmeyer Reaction \[organic-chemistry.org\]](https://organic-chemistry.org)
- [12. Organic Syntheses Procedure \[orgsyn.org\]](https://orgsyn.org)
- [13. m.youtube.com \[m.youtube.com\]](https://m.youtube.com)
- [14. icl-group-sustainability.com \[icl-group-sustainability.com\]](https://icl-group-sustainability.com)
- [15. www-s3-live.kent.edu \[www-s3-live.kent.edu\]](https://www-s3-live.kent.edu)
- [16. Handling liquid bromine and preparing bromine water | Demonstration | RSC Education \[edu.rsc.org\]](https://edu.rsc.org)
- [17. carloth.com \[carloth.com\]](https://carloth.com)
- To cite this document: BenchChem. [Introduction: Strategic Importance and Synthesis Overview]. BenchChem, [2026]. [Online PDF]. Available at: [\[https://www.benchchem.com/product/b1280546/docs#introduction-strategic-importance-and-synthesis-overview\]](https://www.benchchem.com/product/b1280546/docs#introduction-strategic-importance-and-synthesis-overview)

Disclaimer & Data Validity:

The information provided in this document is for Research Use Only (RUO) and is strictly not intended for diagnostic or therapeutic procedures. While BenchChem strives to provide accurate protocols, we make no warranties, express or implied, regarding the fitness of this product for every specific experimental setup.

Technical Support: The protocols provided are for reference purposes. Unsure if this reagent suits your experiment?

Need Industrial/Bulk Grade? [Request Custom Synthesis Quote](#)

BenchChem

Our mission is to be the trusted global source of essential and advanced chemicals, empowering scientists and researchers to drive progress in science and industry.

Contact

Address: 3281 E Guasti Rd

Ontario, CA 91761, United States

Phone: (601) 213-4426

Email: info@benchchem.com

[Contact our Ph.D. Support Team for a compatibility check](#)