

# FT-IR spectroscopy of 1-Iodo-2,2-dimethylpropane functional groups

**Author:** BenchChem Technical Support Team. **Date:** December 2025

## Compound of Interest

Compound Name: 1-Iodo-2,2-dimethylpropane

Cat. No.: B098784

[Get Quote](#)

A comprehensive guide to the FT-IR spectroscopy of **1-iodo-2,2-dimethylpropane**, offering a comparative analysis with related compounds. This document is intended for researchers, scientists, and professionals in the field of drug development, providing key spectral data, experimental protocols, and visual aids to facilitate understanding.

## Comparative Analysis of FT-IR Spectral Data

The FT-IR spectrum of **1-iodo-2,2-dimethylpropane** is characterized by absorption bands corresponding to the vibrations of its constituent functional groups. A comparison with its parent alkane, neopentane, and a structural isomer, tert-butyl iodide, provides valuable insights into the influence of the iodine substituent on the molecule's vibrational modes.

The table below summarizes the key FT-IR absorption peaks for **1-iodo-2,2-dimethylpropane** and its comparative compounds.

Compound	Functional Group	Vibrational Mode	Wavenumber (cm <sup>-1</sup> )
1-Iodo-2,2-dimethylpropane	Neopentyl Group	C-H Stretch	~2960-2870
C-H Bend (CH <sub>3</sub> )	~1470, ~1370		
C-C Skel. (tert-butyl)	~1250		
Methylene Group	CH <sub>2</sub> -I Wag	~1200-1150	
Carbon-Iodine Bond	C-I Stretch	~600-500	
Neopentane	Neopentyl Group	C-H Stretch	2975-2845[1]
C-H Bend (CH <sub>3</sub> )	1470-1370[1]		
tert-Butyl Iodide	tert-Butyl Group	C-H Stretch	2975-2845[2]
C-H Bend (CH <sub>3</sub> )	1470-1365[2]		
C-C Skel. (tert-butyl)	1255-1200[2]		
Carbon-Iodine Bond	C-I Stretch	600-500[2]	

## Key Spectral Interpretations

The FT-IR spectrum of **1-iodo-2,2-dimethylpropane** is expected to exhibit the following characteristic absorption bands:

- C-H Stretching Vibrations:** In the region of 2960-2870 cm<sup>-1</sup>, strong absorptions arise from the symmetric and asymmetric stretching of the C-H bonds in the methyl (CH<sub>3</sub>) and methylene (CH<sub>2</sub>) groups of the neopentyl moiety. This is consistent with the spectral data for neopentane and tert-butyl iodide.[1][2]
- C-H Bending Vibrations:** Characteristic bending vibrations for the methyl groups are expected around 1470 cm<sup>-1</sup> and 1370 cm<sup>-1</sup>. The peak around 1370 cm<sup>-1</sup> is often split into a doublet, characteristic of a gem-dimethyl group.

- C-C Skeletal Vibrations: The vibrations of the carbon skeleton of the tert-butyl group are expected to appear around  $1250\text{ cm}^{-1}$ .<sup>[2]</sup>
- CH<sub>2</sub>-I Wagging Vibration: A key feature for primary iodoalkanes is the methylene wagging vibration, which is anticipated in the  $1200\text{-}1150\text{ cm}^{-1}$  region.
- C-I Stretching Vibration: The stretching vibration of the carbon-iodine bond is found in the far-infrared region, typically between  $600\text{ and }500\text{ cm}^{-1}$ .<sup>[2][3]</sup> This absorption is often weak and may be difficult to observe with standard FT-IR instruments.

## Experimental Protocols

Acquiring a high-quality FT-IR spectrum of liquid **1-iodo-2,2-dimethylpropane** can be achieved using the following standard methods:

### Method 1: Neat Liquid Transmission using a Liquid Cell

This is a traditional method for obtaining the FT-IR spectrum of a pure liquid sample.

- Cell Preparation: Select a demountable or sealed liquid cell with infrared-transparent windows (e.g., NaCl or KBr). Ensure the cell is clean and dry.
- Sample Loading: Using a syringe, carefully introduce a few drops of **1-iodo-2,2-dimethylpropane** into the cell's filling port to create a thin film between the windows.
- Cell Sealing: Securely seal the cell to prevent leakage and evaporation of the sample.
- Background Spectrum: Acquire a background spectrum of the empty instrument to account for atmospheric and instrumental contributions.
- Sample Spectrum: Place the loaded liquid cell in the sample holder of the FT-IR spectrometer and acquire the sample spectrum.
- Data Processing: The instrument software will automatically ratio the sample spectrum against the background spectrum to produce the final absorbance or transmittance spectrum.

- **Cleaning:** After analysis, thoroughly clean the cell with a suitable solvent (e.g., dry acetone or isopropanol) and store it in a desiccator.

## Method 2: Attenuated Total Reflectance (ATR)

ATR is a modern and convenient technique that requires minimal sample preparation.

- **Crystal Cleaning:** Ensure the surface of the ATR crystal (commonly diamond or zinc selenide) is clean. This can be done by wiping it with a soft cloth dampened with a volatile solvent like isopropanol.
- **Background Spectrum:** Record a background spectrum with the clean, empty ATR crystal.
- **Sample Application:** Place a single drop of **1-iodo-2,2-dimethylpropane** directly onto the center of the ATR crystal.
- **Sample Spectrum:** Acquire the FT-IR spectrum. The instrument's software will perform the background correction.
- **Cleaning:** After the measurement, clean the ATR crystal by wiping away the sample with a soft cloth and a suitable solvent.

## Visualizing Molecular Vibrations and Experimental Workflow

To further clarify the relationship between the molecular structure and its spectral features, as well as the experimental process, the following diagrams are provided.

## FT-IR Signaling Pathway of 1-Iodo-2,2-dimethylpropane

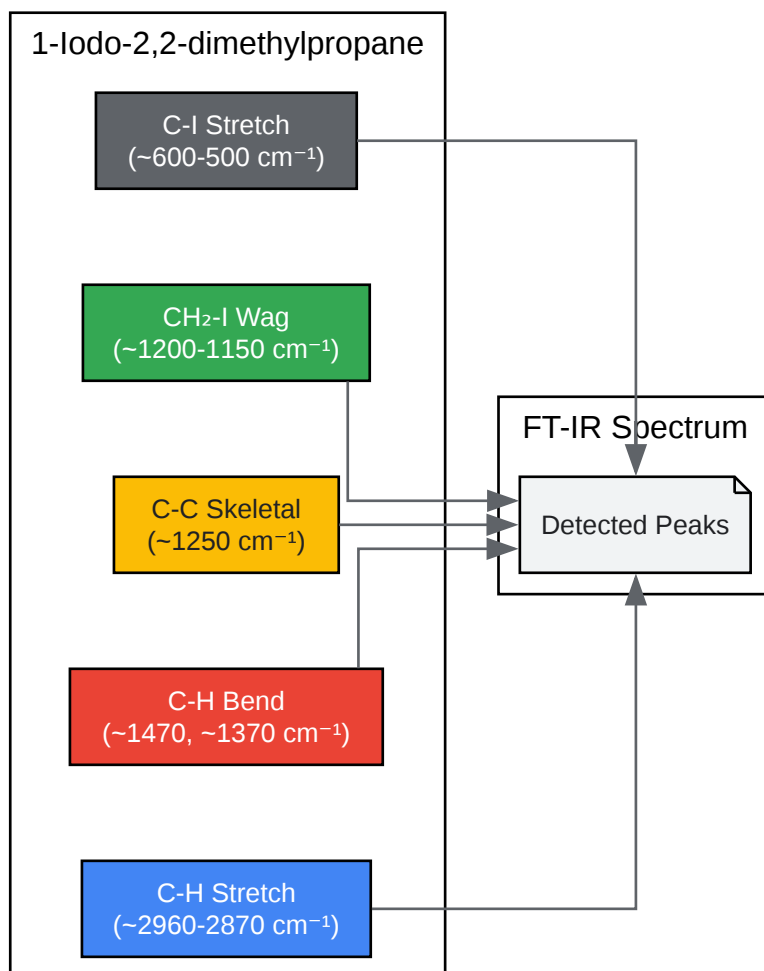

[Click to download full resolution via product page](#)

Caption: Molecular vibrations of **1-Iodo-2,2-dimethylpropane** and their corresponding FT-IR spectral regions.

## Experimental Workflow for Liquid Sample FT-IR Analysis

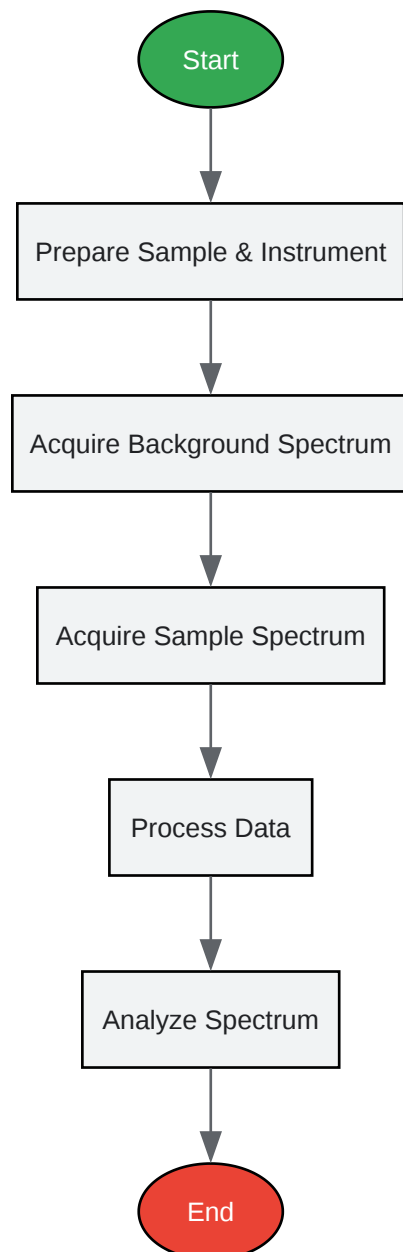

[Click to download full resolution via product page](#)

Caption: General workflow for obtaining an FT-IR spectrum of a liquid sample.

### Need Custom Synthesis?

BenchChem offers custom synthesis for rare earth carbides and specific isotopic labeling.

Email: [info@benchchem.com](mailto:info@benchchem.com) or [Request Quote Online](#).

## References

- 1. infrared spectrum of 2,2-dimethylpropane prominent wavenumbers cm-1 detecting ? functional groups present finger print for identification of neopentane image diagram doc brown's advanced organic chemistry revision notes [docbrown.info]
- 2. infrared spectrum of 2-iodo-2-methylpropane (CH<sub>3</sub>)<sub>3</sub>CI prominent wavenumbers cm-1 detecting functional groups present finger print for identification of tert-butyl iodide image diagram doc brown's advanced organic chemistry revision notes [docbrown.info]
- 3. infrared spectrum of 1-iodo-2-methylpropane C<sub>4</sub>H<sub>9</sub>I (CH<sub>3</sub>)<sub>2</sub>CHCH<sub>2</sub>I prominent wavenumbers cm-1 detecting functional groups present finger print for identification of isobutyl iodide image diagram doc brown's advanced organic chemistry revision notes [docbrown.info]
- To cite this document: BenchChem. [FT-IR spectroscopy of 1-Iodo-2,2-dimethylpropane functional groups]. BenchChem, [2025]. [Online PDF]. Available at: [https://www.benchchem.com/product/b098784#ft-ir-spectroscopy-of-1-iodo-2-2-dimethylpropane-functional-groups]

---

### Disclaimer & Data Validity:

The information provided in this document is for Research Use Only (RUO) and is strictly not intended for diagnostic or therapeutic procedures. While BenchChem strives to provide accurate protocols, we make no warranties, express or implied, regarding the fitness of this product for every specific experimental setup.

**Technical Support:** The protocols provided are for reference purposes. Unsure if this reagent suits your experiment? [[Contact our Ph.D. Support Team for a compatibility check](#)]

**Need Industrial/Bulk Grade?** [Request Custom Synthesis Quote](#)

# BenchChem

Our mission is to be the trusted global source of essential and advanced chemicals, empowering scientists and researchers to drive progress in science and industry.

## Contact

Address: 3281 E Guasti Rd

Ontario, CA 91761, United States

Phone: (601) 213-4426

Email: [info@benchchem.com](mailto:info@benchchem.com)