

# 2-Pyruvoylaminobenzamide: A Comparative Analysis Against Established Kinase Inhibitors

**Author:** BenchChem Technical Support Team. **Date:** December 2025

## Compound of Interest

Compound Name: 2-Pyruvoylaminobenzamide

Cat. No.: B097163

[Get Quote](#)

For Researchers, Scientists, and Drug Development Professionals

This guide provides a comparative overview of the novel kinase inhibitor, **2-Pyruvoylaminobenzamide**, alongside three established kinase inhibitors: Imatinib, Dasatinib, and Gefitinib. The following sections detail their target specificities, inhibitory potencies, and the experimental protocols used to derive this data.

Disclaimer: As of the latest literature review, specific kinase inhibitory data for **2-Pyruvoylaminobenzamide** is not publicly available. The data presented for this compound is hypothetical and is intended to serve as a template for comparative analysis once experimental results are obtained.

## Comparative Kinase Inhibitor Profile

The table below summarizes the primary targets and half-maximal inhibitory concentrations (IC50) for each inhibitor. Lower IC50 values indicate greater potency.

Inhibitor	Primary Target(s)	IC50 (nM)
2-Pyruvoylaminobenzamide	Hypothetical: Aurora Kinase A	50 (Hypothetical)
Imatinib	BCR-ABL, c-KIT, PDGFR	400 (for c-ABL)
Dasatinib	BCR-ABL, SRC family kinases, c-KIT, PDGFR $\beta$	<1 (for BCR-ABL)
Gefitinib	EGFR	26-57

## Experimental Protocols

The following are detailed methodologies for key experiments that can be used to evaluate and compare the efficacy of kinase inhibitors.

### In Vitro Kinase Activity Assay

This protocol is designed to measure the direct inhibitory effect of a compound on the activity of a purified kinase enzyme.

Materials:

- Purified recombinant kinase (e.g., Aurora Kinase A)
- Kinase-specific substrate peptide
- ATP (Adenosine triphosphate)
- Kinase assay buffer (e.g., 50 mM Tris-HCl, pH 7.5, 10 mM MgCl<sub>2</sub>, 1 mM EGTA, 2 mM DTT, 0.01% Tween-20)
- Test compounds (**2-Pyruvoylaminobenzamide** and established inhibitors) dissolved in DMSO
- ADP-Glo™ Kinase Assay Kit (Promega) or similar
- 96-well or 384-well microplates

- Plate reader capable of luminescence detection

Procedure:

- Compound Preparation: Prepare serial dilutions of the test compounds in DMSO. A typical starting concentration is 10 mM.
- Reaction Setup:
  - Add 5  $\mu$ L of kinase assay buffer to each well of the microplate.
  - Add 1  $\mu$ L of the diluted test compound to the appropriate wells. Include a DMSO-only control (vehicle control) and a no-kinase control (background).
  - Add 2  $\mu$ L of the kinase-substrate mixture (pre-diluted in kinase assay buffer) to each well.
  - Initiate the kinase reaction by adding 2  $\mu$ L of ATP solution. The final ATP concentration should be at or near the  $K_m$  for the specific kinase.
- Incubation: Incubate the plate at 30°C for 1 hour.
- Detection:
  - Stop the kinase reaction and measure the amount of ADP produced using the ADP-Glo™ Kinase Assay Kit according to the manufacturer's instructions.
  - This involves adding ADP-Glo™ Reagent to deplete the remaining ATP, followed by the addition of Kinase Detection Reagent to convert ADP to ATP and generate a luminescent signal.
- Data Analysis:
  - Measure luminescence using a plate reader.
  - Calculate the percentage of kinase inhibition for each compound concentration relative to the DMSO control.

- Determine the IC50 value by fitting the data to a dose-response curve using appropriate software (e.g., GraphPad Prism).[\[1\]](#)[\[2\]](#)[\[3\]](#)

## Cell-Based Viability Assay

This protocol assesses the effect of kinase inhibitors on the proliferation and viability of cancer cell lines.

Materials:

- Cancer cell line expressing the target kinase (e.g., a cell line with overactive Aurora Kinase A)
- Complete cell culture medium (e.g., DMEM with 10% FBS)
- Test compounds dissolved in DMSO
- MTT (3-(4,5-dimethylthiazol-2-yl)-2,5-diphenyltetrazolium bromide) or CellTiter-Glo® Luminescent Cell Viability Assay (Promega)
- 96-well cell culture plates
- Spectrophotometer or luminometer

Procedure:

- Cell Seeding: Seed cells into a 96-well plate at a density of 5,000-10,000 cells per well in 100  $\mu$ L of complete medium. Allow cells to attach overnight.
- Compound Treatment:
  - Prepare serial dilutions of the test compounds in cell culture medium.
  - Remove the old medium from the wells and add 100  $\mu$ L of the medium containing the test compounds. Include a DMSO-only control.
- Incubation: Incubate the cells for 72 hours at 37°C in a humidified incubator with 5% CO<sub>2</sub>.
- Viability Measurement (MTT Assay):

- Add 10  $\mu\text{L}$  of MTT solution (5 mg/mL in PBS) to each well and incubate for 4 hours.
- Add 100  $\mu\text{L}$  of solubilization solution (e.g., 10% SDS in 0.01 M HCl) to each well and incubate overnight to dissolve the formazan crystals.
- Measure the absorbance at 570 nm using a spectrophotometer.[4][5]
- Data Analysis:
  - Calculate the percentage of cell viability for each treatment relative to the DMSO control.
  - Determine the IC50 value by plotting cell viability against the logarithm of the compound concentration and fitting the data to a sigmoidal dose-response curve.

## Visualizations

### Signaling Pathway

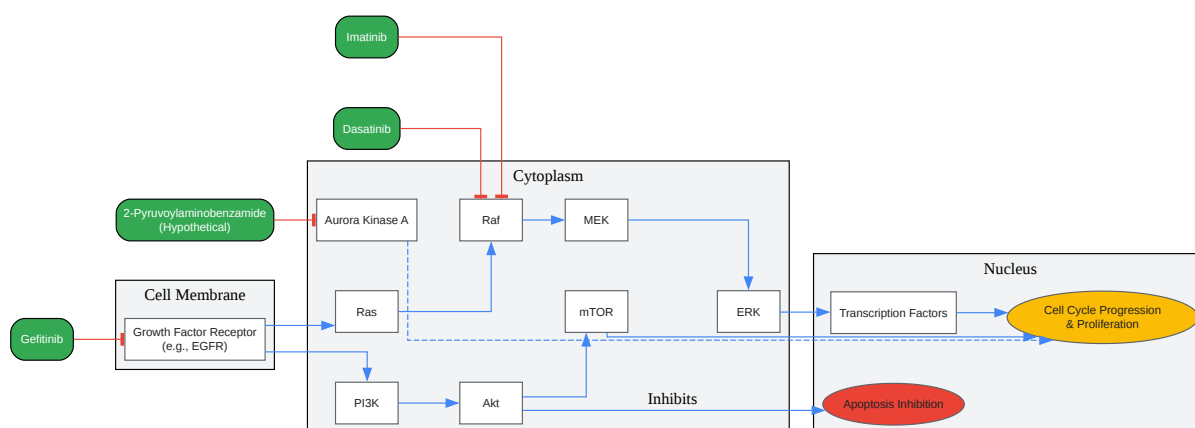

[Click to download full resolution via product page](#)

Caption: A simplified diagram of common kinase signaling pathways and the points of inhibition for the compared compounds.

## Experimental Workflow: In Vitro Kinase Assay

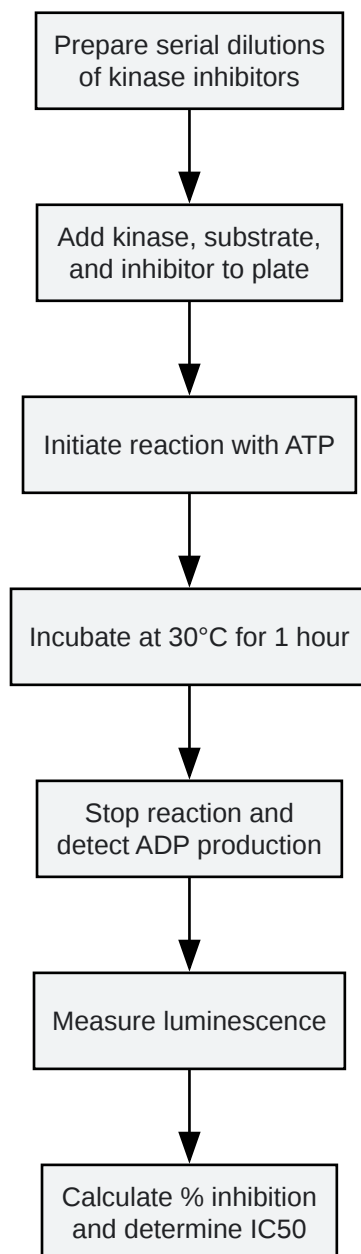

[Click to download full resolution via product page](#)

Caption: Workflow for a typical in vitro kinase activity assay.

## Experimental Workflow: Cell Viability Assay

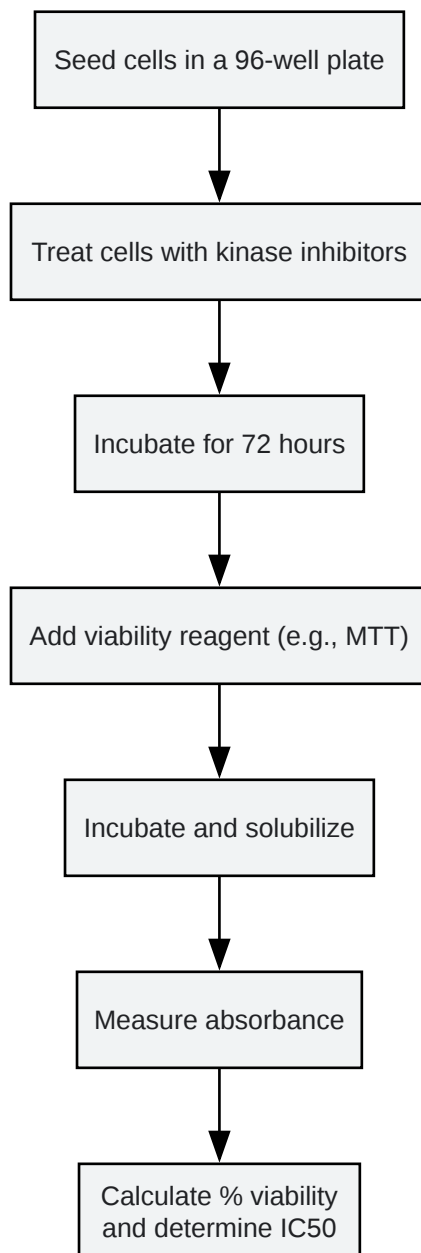

[Click to download full resolution via product page](#)

Caption: Workflow for a cell-based viability assay.

### **Need Custom Synthesis?**

*BenchChem offers custom synthesis for rare earth carbides and specific isotopic labeling.*

*Email: [info@benchchem.com](mailto:info@benchchem.com) or [Request Quote Online](#).*

## References

- 1. biorxiv.org [biorxiv.org]
- 2. The Relationship between the IC50 Values and the Apparent Inhibition Constant in the Study of Inhibitors of Tyrosinase Diphenolase Activity Helps Confirm the Mechanism of Inhibition - PMC [pmc.ncbi.nlm.nih.gov]
- 3. biorxiv.org [biorxiv.org]
- 4. Cell viability assay [bio-protocol.org]
- 5. Cell Viability Assays - Assay Guidance Manual - NCBI Bookshelf [ncbi.nlm.nih.gov]
- To cite this document: BenchChem. [2-Pyruvoylaminobenzamide: A Comparative Analysis Against Established Kinase Inhibitors]. BenchChem, [2025]. [Online PDF]. Available at: [https://www.benchchem.com/product/b097163#2-pyruvoylaminobenzamide-versus-established-kinase-inhibitors]

---

### Disclaimer & Data Validity:

The information provided in this document is for Research Use Only (RUO) and is strictly not intended for diagnostic or therapeutic procedures. While BenchChem strives to provide accurate protocols, we make no warranties, express or implied, regarding the fitness of this product for every specific experimental setup.

**Technical Support:** The protocols provided are for reference purposes. Unsure if this reagent suits your experiment? [[Contact our Ph.D. Support Team for a compatibility check](#)]

**Need Industrial/Bulk Grade?** [Request Custom Synthesis Quote](#)

## BenchChem

Our mission is to be the trusted global source of essential and advanced chemicals, empowering scientists and researchers to drive progress in science and industry.

### Contact

Address: 3281 E Guasti Rd

Ontario, CA 91761, United States

Phone: (601) 213-4426

Email: [info@benchchem.com](mailto:info@benchchem.com)