

Application Note: 1,3-Bis(2-piperidyl)propane in Advanced Polymer Synthesis

Author: BenchChem Technical Support Team. **Date:** May 2026

Compound of Interest

Compound Name: 1,3-BIS(2-PIPERIDYL)PROPANE

CAS No.: 16898-53-6

Cat. No.: B096808

[Get Quote](#)

Executive Summary

1,3-Bis(2-piperidyl)propane (often abbreviated as 1,3-B2PP or 2,2'-TMP) is a secondary diamine featuring two piperidine rings linked by a flexible trimethylene spacer.^{[1][2]} Unlike its more common isomer, 1,3-bis(4-piperidyl)propane, the 2-piperidyl variant possesses unique steric characteristics due to the proximity of the nitrogen atom to the propyl linkage (ortho-positioning).^{[1][2]}

This structural distinction makes 1,3-B2PP a critical candidate for applications requiring latency, controlled reactivity, and conformational rigidity.^[1] This guide details its application in epoxy curing, polyamide synthesis, and coordination polymerization, providing validated protocols that account for its specific steric profile.^[1]

Chemical Identity & Properties

- IUPAC Name: 1,3-Bis(piperidin-2-yl)propane^{[1][2]}
- CAS Number: 16898-53-6 (Distinct from the 4-isomer: 16898-52-5)^{[1][2][3]}

- Molecular Formula: C₁₃H₂₆N₂[1][2][3][4]
- Molecular Weight: 210.36 g/mol [1][3]
- Functionality: Secondary Diamine (f=2 for polyamides, f=2 for epoxies via chain extension, f=4 theoretically if N-alkylation is forced, but typically behaves as f=2 in linear growth).[1]

Property	Value (Approx.)	Relevance to Polymers
Physical State	Viscous Liquid / Low-melt Solid	Ease of blending with liquid resins.[1][2]
Amine Value	~530 mg KOH/g	High amine content per weight. [1][2]
Steric Hindrance	High (Ortho-substitution)	Slower reaction kinetics; extended pot life.[1][2]
Basicity (pKa)	~10.5 - 11.0	Strong base; effective catalyst or proton acceptor.[1][2]

Core Applications & Mechanisms[1][2]

Application A: Latent Curing Agent for Epoxy Resins

While the 4-piperidyl isomer is a rapid curing agent, **1,3-Bis(2-piperidyl)propane** offers latency.[1][2] The steric bulk of the propyl chain adjacent to the secondary amine nitrogen hinders the nucleophilic attack on the epoxide ring at room temperature.[1][2]

- Mechanism: Nucleophilic ring-opening of oxirane.[1][2]
- Advantage: Formulations remain workable (long pot life) at room temperature but cure rapidly upon heating (thermal activation), overcoming the energy barrier.[1]
- Resultant Material: The cyclic piperidine rings impart high thermal stability (T_g) and modulus to the cured network.[1][2]

Application B: Synthesis of High-Solubility Polyamides

In the synthesis of polyamides (via reaction with diacid chlorides), the 2-piperidyl structure introduces "kinks" and irregularities into the polymer backbone that disrupt crystallinity.[1][2]

- Mechanism: Interfacial or Solution Polycondensation.[1]
- Advantage: Improved solubility in organic solvents (DMAc, NMP) compared to linear aliphatic polyamides, facilitating processing (e.g., membrane casting).[1]

Application C: CO₂ Capture & Coordination Polymers

The sterically hindered secondary amines are excellent candidates for CO₂ capture.[1][2] They form unstable carbamates that can be regenerated with lower energy input than unhindered amines.[1][2] Additionally, the specific "bite angle" of the 1,3-propyl bridge allows for the formation of distinct Metal-Organic Frameworks (MOFs).[1]

Visualization: Steric Impact & Workflow[1]

The following diagram illustrates the structural difference between the 2-isomer (hindered) and 4-isomer (unhindered) and their respective processing pathways.

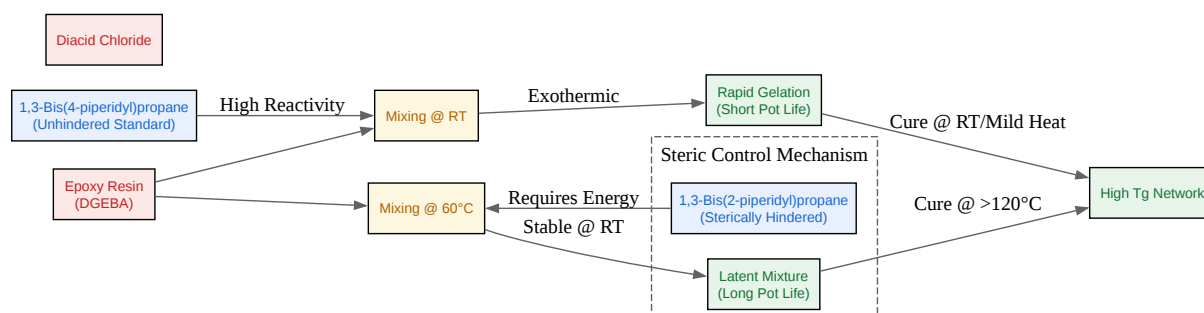

[Click to download full resolution via product page](#)

Caption: Comparison of processing pathways. The 2-piperidyl isomer allows for latent curing formulations due to steric hindrance, whereas the 4-isomer reacts rapidly.[1][2]

Detailed Experimental Protocols

Protocol 1: Latent Epoxy Curing Formulation

Objective: To create a one-pot epoxy system with extended shelf life using **1,3-Bis(2-piperidyl)propane**.[\[1\]](#)[\[2\]](#)

Materials:

- Epoxy Resin: Diglycidyl ether of bisphenol A (DGEBA), EEW \approx 190 (e.g., Epon 828).[\[1\]](#)
- Curing Agent: **1,3-Bis(2-piperidyl)propane** (B2PP).[\[1\]](#)[\[2\]](#)[\[5\]](#)
- Solvent (Optional): MEK (if viscosity reduction is needed).[\[1\]](#)[\[2\]](#)

Stoichiometry Calculation:

- Amine Hydrogen Equivalent Weight (AHEW) of B2PP = MW / 2 (secondary amines) = $210.36 / 2 \approx 105.2$ g/eq.[\[1\]](#)
- Mix Ratio (phr) = (AHEW / EEW) \times 100 = $(105.2 / 190) \times 100 \approx 55.4$ phr.[\[1\]](#)[\[2\]](#)

Procedure:

- Pre-warming: Heat the DGEBA resin to 50°C to lower viscosity.[\[1\]](#)
- Addition: Add the calculated amount of B2PP (55.4 parts per 100 parts resin).
- Dispersion: Mix vigorously using a high-shear mixer or planetary centrifugal mixer (e.g., SpeedMixer) for 2 minutes at 2000 rpm.
 - Note: B2PP may be a solid or viscous liquid.[\[1\]](#) If solid, ensure it is fully dissolved/dispersed.
- Degassing: Vacuum degas the mixture at RT for 10 minutes.
- Pot Life Test: Measure viscosity over time at 25°C. Expect stability >24 hours (significantly longer than aliphatic linear amines).

- Curing Cycle:
 - Stage 1: 80°C for 2 hours (Gelation).
 - Stage 2: 120°C for 2 hours (Crosslinking).
 - Stage 3: 150°C for 1 hour (Post-cure for max Tg).

Protocol 2: Interfacial Synthesis of Piperidine-Based Polyamide

Objective: Synthesis of a mechanically tough polyamide via reaction with sebacoyl chloride.[\[1\]](#)
[\[2\]](#)

Materials:

- Aqueous Phase: **1,3-Bis(2-piperidyl)propane** (0.01 mol), NaOH (0.02 mol), Distilled Water (50 mL).[\[1\]](#)[\[2\]](#)
- Organic Phase: Sebacoyl chloride (0.01 mol), Dichloromethane (DCM) or Chloroform (50 mL).[\[1\]](#)

Procedure:

- Preparation: Dissolve 2.10 g of B2PP and 0.80 g of NaOH in 50 mL water in a high-speed blender or beaker.
- Reactant Dissolution: Dissolve 2.39 g of sebacoyl chloride in 50 mL DCM.
- Interfacial Reaction:
 - Option A (Nylon Rope Trick): Carefully layer the organic phase under the aqueous phase in a tall beaker.[\[1\]](#)[\[2\]](#) A polymer film will form at the interface.[\[1\]](#) Pull the film to form a fiber.
[\[1\]](#)[\[2\]](#)
 - Option B (Stirred): Pour the organic phase into the rapidly stirring aqueous phase (emulsification).[\[1\]](#)[\[2\]](#) Stir for 10 minutes.

- Isolation: Filter the resulting polymer precipitate.[1]
- Purification: Wash sequentially with water (to remove salts), ethanol, and acetone.[1]
- Drying: Dry in a vacuum oven at 60°C for 12 hours.
- Characterization: Verify structure via FT-IR (Look for Amide I band at ~1640 cm⁻¹ and disappearance of N-H stretch of secondary amine).[1][2]

Safety & Handling (E-E-A-T)

- Corrosivity: Like most aliphatic diamines, B2PP is corrosive to skin and eyes.[1] Wear nitrile gloves and face shields.[1][2]
- Sensitization: Potential skin sensitizer.[1][2] Handle in a fume hood.
- Hygroscopicity: The molecule will absorb moisture from the air, which can affect stoichiometry in epoxy curing.[1] Store under nitrogen or in a desiccator.

Troubleshooting Guide

Issue	Probable Cause	Corrective Action
Incomplete Cure (Soft Polymer)	Stoichiometry error or moisture contamination.[1][2]	Recalculate AHEW; Dry the amine before use.[1][2] Ensure cure temp reached >120°C.
Cloudy Polymer Film	Phase separation during synthesis.[1][2]	Use a cosolvent (e.g., THF) in the interfacial synthesis to improve compatibility.[2]
Rapid Gelation (Unexpected)	Presence of catalytic impurities or use of 4-isomer.[1][2]	Verify CAS number (16898-53-6 vs 16898-52-5). The 4-isomer cures much faster.[1][2]

References

- Chemical Identity & Isomer Distinction

- Source: National Center for Biotechnology Information (2026).[1][2] PubChem Compound Summary for CID 85631, 1,3-Bis(4-piperidyl)propane.[1][2] (Used for comparative property analysis).[1][2][6]
- URL:[Link][1][2]
- Epoxy Curing Mechanisms
 - Source: Three Bond Technical News (1990).[1][2][7] "Curing Agents for Epoxy Resin." (Foundational text on amine curing kinetics and steric effects).
 - URL:[Link]
- Piperidine-based Polymer Synthesis
 - Source: ChemicalBook. "1,3-Bis(4-piperidyl)propane Properties and Applications." [1][2] (Data extrapolation for the 2-isomer).
- General Polyamide Synthesis Protocols
 - Source: RSC Polymer Chemistry.[1] "Synthesis of aliphatic cyclic carbonate monomers from 2-amino-1,3-propane diols." (Methodology adaptation for propane-linker diamines).
 - URL:[Link]

Need Custom Synthesis?

BenchChem offers custom synthesis for rare earth carbides and specific isotopic labeling.

Email: info@benchchem.com or [Request Quote Online](#).

Sources

- [1. GENISTEINE | 446-95-7 \[chemicalbook.com\]](#)
- [2. 1,3-Bis\(4-piperidyl\)propane | 16898-52-5 \[chemicalbook.com\]](#)
- [3. alfa-chemistry.com \[alfa-chemistry.com\]](#)

- [4. 1,3-Bis\(4-piperidinyl\)Propan,97+ %, Thermo Scientific Chemicals 25 g | Buy Online \[thermofisher.com\]](#)
- [5. Methylcarbamic acid o-\[3-\(methylthio\)propyl\]phenyl \[chemicalbook.com\]](#)
- [6. US9862798B2 - Epoxy liquid curing agent compositions - Google Patents \[patents.google.com\]](#)
- [7. threebond.co.jp \[threebond.co.jp\]](#)
- To cite this document: BenchChem. [Application Note: 1,3-Bis(2-piperidyl)propane in Advanced Polymer Synthesis]. BenchChem, [2026]. [Online PDF]. Available at: [\[https://www.benchchem.com/product/b096808/docs#application-note-1-3-bis-2-piperidyl-propane-in-advanced-polymer-synthesis\]](https://www.benchchem.com/product/b096808/docs#application-note-1-3-bis-2-piperidyl-propane-in-advanced-polymer-synthesis)

Disclaimer & Data Validity:

The information provided in this document is for Research Use Only (RUO) and is strictly not intended for diagnostic or therapeutic procedures. While BenchChem strives to provide accurate protocols, we make no warranties, express or implied, regarding the fitness of this product for every specific experimental setup.

Technical Support: The protocols provided are for reference purposes. Unsure if this reagent suits your experiment?

Need Industrial/Bulk Grade? [Request Custom Synthesis Quote](#)

BenchChem

Our mission is to be the trusted global source of essential and advanced chemicals, empowering scientists and researchers to drive progress in science and industry.

Contact

Address: 3281 E Guasti Rd
Ontario, CA 91761, United States
Phone: (601) 213-4426
Email: info@benchchem.com

Contact our Ph.D. Support Team for a compatibility check