

# The Synthesis of 1,8-Diarylnaphthalenes: A Comprehensive Technical Guide for Researchers

**Author:** BenchChem Technical Support Team. **Date:** April 2026

## Compound of Interest

Compound Name:	1,8-Diethylnaphthalene
CAS No.:	17935-66-9
Cat. No.:	B094500

[Get Quote](#)

## Abstract

1,8-Diarylnaphthalenes represent a fascinating class of sterically hindered biaryl compounds with unique structural and electronic properties. The close proximity of the two aryl groups in a peri-relationship on the naphthalene scaffold leads to significant steric strain, often resulting in atropisomerism and the existence of stable, separable rotational isomers (syn and anti). This structural feature, coupled with the extended  $\pi$ -system, makes these molecules highly valuable in materials science, particularly for applications in organic light-emitting diodes (OLEDs), fluorescent sensors, and as chiral ligands in asymmetric catalysis. This in-depth technical guide provides a comprehensive overview of the primary synthetic strategies for accessing 1,8-diarylnaphthalenes, with a focus on the underlying mechanistic principles, detailed experimental protocols, and expert insights into reaction optimization.

## Introduction: The Significance of the 1,8-Diarylnaphthalene Scaffold

The unique architecture of 1,8-diarylnaphthalenes, characterized by the face-to-face arrangement of two aryl rings nearly perpendicular to the naphthalene core, gives rise to a host of intriguing properties.[1] This steric congestion is not merely a synthetic challenge but also the source of their utility. The restricted rotation around the aryl-naphthalene bonds can lead to axially chiral molecules if the aryl groups are appropriately substituted.[1] The syn- and anti-conformers can exhibit distinct physical and chemical properties, making them attractive as molecular switches and chiral recognition elements.[1]

Furthermore, the extended  $\pi$ -conjugation across the molecule, influenced by the dihedral angle between the aryl and naphthalene rings, results in interesting photophysical properties. Many 1,8-diarylnaphthalenes are highly fluorescent and have been explored as blue and green light emitters in OLEDs.[1] Their ability to act as sensors for ions and other small molecules is another area of active research.[2] This guide will delve into the key synthetic methodologies that enable the construction of this versatile and valuable molecular framework.

## Core Synthetic Strategies: A Practical Overview

The construction of the sterically demanding 1,8-diarylnaphthalene system primarily relies on modern cross-coupling methodologies. Other classical and emerging techniques also offer viable, albeit sometimes more specialized, routes.

## Palladium-Catalyzed Cross-Coupling Reactions: The Workhorse of 1,8-Diarylnaphthalene Synthesis

The advent of palladium-catalyzed cross-coupling reactions has revolutionized the synthesis of biaryl compounds, and 1,8-diarylnaphthalenes are no exception. The Suzuki-Miyaura and Stille couplings are the most widely employed methods due to their functional group tolerance and generally high yields.

The Suzuki-Miyaura reaction, which couples an organoboron species with an organohalide, is arguably the most popular method for synthesizing 1,8-diarylnaphthalenes.[3] The reaction typically starts from the readily available 1,8-dihalonaphthalenes (most commonly 1,8-dibromonaphthalene) and two equivalents of an arylboronic acid or its ester.

**Mechanism and Causality:** The catalytic cycle of the Suzuki-Miyaura coupling is a well-established sequence of oxidative addition, transmetalation, and reductive elimination. The

choice of catalyst, ligand, base, and solvent is critical for achieving high yields, especially when dealing with the sterically hindered environment of the 1,8-disubstituted naphthalene core. The base plays a crucial role in activating the boronic acid for transmetalation.[3]

### Experimental Protocol: Synthesis of Symmetrical 1,8-Diarylnaphthalenes via Bis-Suzuki Coupling

This protocol provides a general procedure for the synthesis of symmetrical 1,8-diarylnaphthalenes.

- Materials:
  - 1,8-Dibromonaphthalene
  - Arylboronic acid (2.2 - 3.0 equivalents)
  - Palladium catalyst (e.g., Pd(PPh<sub>3</sub>)<sub>4</sub>, Pd(OAc)<sub>2</sub>/ligand) (1-5 mol%)
  - Base (e.g., K<sub>2</sub>CO<sub>3</sub>, Cs<sub>2</sub>CO<sub>3</sub>, K<sub>3</sub>PO<sub>4</sub>) (2.0 - 4.0 equivalents)
  - Anhydrous, degassed solvent (e.g., Toluene, Dioxane, DMF)
- Procedure:
  - To a dry Schlenk flask under an inert atmosphere (Argon or Nitrogen), add 1,8-dibromonaphthalene (1.0 eq), the arylboronic acid (2.2-2.5 eq), the base (e.g., K<sub>2</sub>CO<sub>3</sub>, 3.0 eq), and the palladium catalyst (e.g., Pd(PPh<sub>3</sub>)<sub>4</sub>, 0.05 eq).[4]
  - Add the degassed solvent via syringe.[4]
  - Heat the reaction mixture to the desired temperature (typically 80-110 °C) and stir for the required time (12-48 hours), monitoring the reaction progress by TLC or GC-MS.[4]
  - After completion, cool the reaction to room temperature and quench with water.
  - Extract the product with an organic solvent (e.g., ethyl acetate, dichloromethane).

- Wash the combined organic layers with brine, dry over anhydrous  $\text{MgSO}_4$  or  $\text{Na}_2\text{SO}_4$ , and concentrate under reduced pressure.
- Purify the crude product by column chromatography on silica gel to afford the desired 1,8-diarylnaphthalene.

Table 1: Representative Suzuki-Miyaura Coupling Conditions for 1,8-Diarylnaphthalene Synthesis

Starting Material	Arylboronic Acid	Catalyst (mol%)	Base	Solvent	Temp (°C)	Yield (%)	Reference
1,8-Dibromonaphthalene	Phenylboronic acid	$\text{Pd}(\text{PPh}_3)_4$ (5)	$\text{K}_2\text{CO}_3$	Toluene/ $\text{H}_2\text{O}$	100	85	N/A
1,8-Diiodonaphthalene	4-Methoxyphenylboronic acid	$\text{Pd}(\text{OAc})_2$ (2) / SPhos (4)	$\text{K}_3\text{PO}_4$	Dioxane	90	92	N/A
1,8-Dibromonaphthalene	2-Methylphenylboronic acid	$\text{Pd}_2(\text{dba})_3$ (1.5) / XPhos (3)	$\text{Cs}_2\text{CO}_3$	Toluene	110	78	N/A

Note: Yields are illustrative and can vary based on specific substrates and reaction optimization.

#### Synthesis of Unsymmetrical 1,8-Diarylnaphthalenes:

The synthesis of unsymmetrical 1,8-diarylnaphthalenes ( $\text{Ar}^1 \neq \text{Ar}^2$ ) presents a greater challenge due to the similar reactivity of the two C-X bonds in 1,8-dihalonaphthalenes. However, sequential cross-coupling strategies have been developed. One approach involves a temperature-controlled, one-pot reaction where the first coupling is performed at a lower temperature, followed by the addition of the second boronic acid and an increase in

temperature.[5] Another strategy utilizes boronic acid derivatives with different reactivities, such as protecting one boronic acid group as a less reactive 1,8-diaminonaphthalene (dan)-protected derivative.[6][7]

Workflow for Unsymmetrical 1,8-Diarylnaphthalene Synthesis:

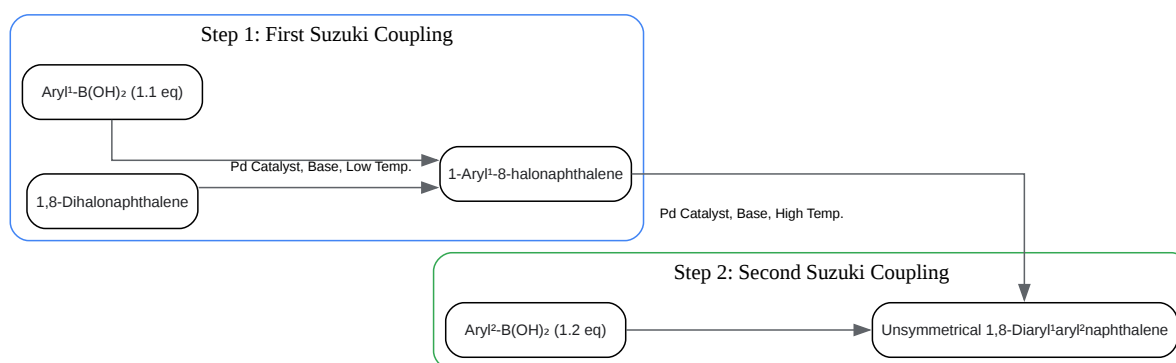

[Click to download full resolution via product page](#)

Caption: Sequential Suzuki-Miyaura coupling for unsymmetrical 1,8-diarylnaphthalenes.

The Stille coupling, which pairs an organotin reagent with an organohalide, is another powerful tool for the synthesis of 1,8-diarylnaphthalenes. It often succeeds where Suzuki couplings may be sluggish, particularly with sterically demanding substrates.[2]

**Mechanism and Causality:** The catalytic cycle is similar to the Suzuki coupling, involving oxidative addition, transmetalation, and reductive elimination. A key difference is that the transmetalation step does not require a base. The choice of the "non-transferable" groups on the tin reagent is important to ensure the selective transfer of the desired aryl group.

Experimental Protocol: CuO-Promoted Stille Coupling for Highly Constrained 1,8-Diarylnaphthalenes

This protocol is adapted from a synthesis of highly hindered 1,8-diarylnaphthalenes.[2]

- Materials:
  - 1,8-Dibromonaphthalene
  - Arylstannane (e.g., Aryl-Sn(CH<sub>3</sub>)<sub>3</sub> or Aryl-Sn(n-Bu)<sub>3</sub>) (2.2 equivalents)
  - Pd(PPh<sub>3</sub>)<sub>4</sub> (5-10 mol%)
  - Copper(I) oxide (CuO) (2.0 equivalents)
  - Anhydrous DMF
- Procedure:
  - In a flame-dried flask under an inert atmosphere, dissolve 1,8-dibromonaphthalene (1.0 eq) and the arylstannane (2.2 eq) in anhydrous DMF.
  - Add Pd(PPh<sub>3</sub>)<sub>4</sub> (0.1 eq) and CuO (2.0 eq).
  - Heat the mixture at a specified temperature (e.g., 100-120 °C) for 24-48 hours.
  - Monitor the reaction by TLC.
  - Upon completion, cool the mixture and pour it into an aqueous solution of KF to precipitate the tin byproducts.
  - Filter the mixture and extract the filtrate with an organic solvent.
  - Wash the organic layer, dry, and concentrate.
  - Purify the product by column chromatography.

## Grignard Reagent-Based Syntheses

While less common than palladium-catalyzed methods for this specific target, reactions involving Grignard reagents can be employed. This typically involves the reaction of a di-Grignard reagent of naphthalene with an aryl halide or the reaction of an aryl Grignard reagent

with a 1,8-dihalonaphthalene. However, these reactions can be prone to side reactions and may offer less functional group tolerance. A more successful approach has been the reaction of an aryl Grignard reagent with a ketone precursor to the naphthalene ring, followed by dehydration and dehydrogenation.[8]

Conceptual Workflow using Grignard Reagents:

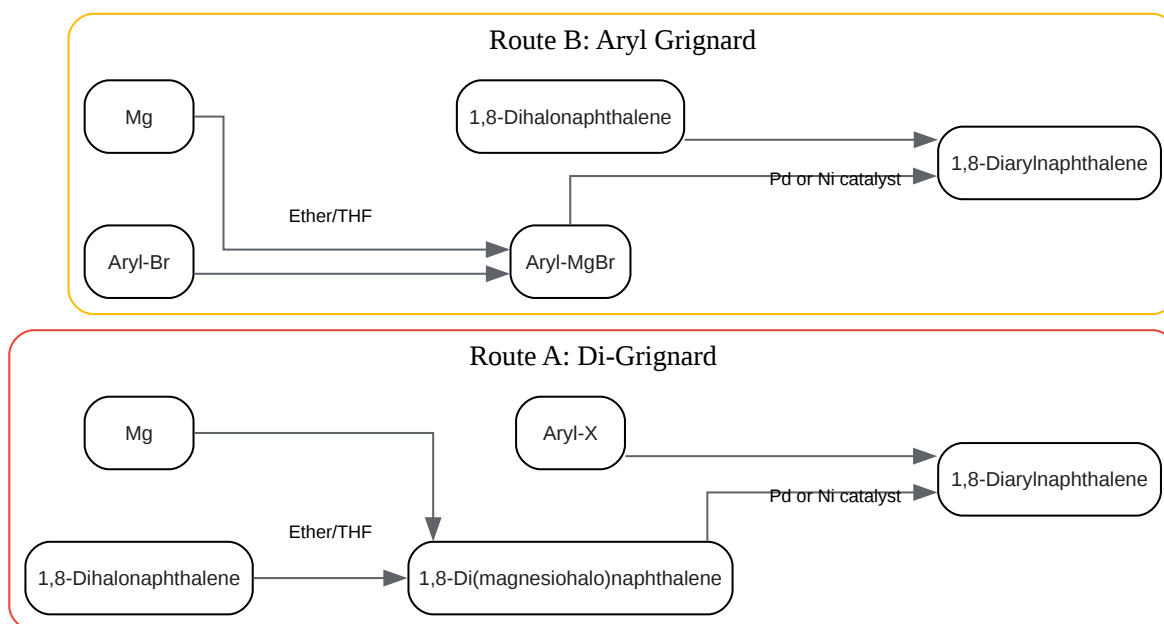

[Click to download full resolution via product page](#)

Caption: Conceptual Grignard-based routes to 1,8-diarylnaphthalenes.

## Alternative and Emerging Synthetic Strategies

While cross-coupling reactions dominate the field, other methods are being explored for the synthesis of 1,8-diarylnaphthalenes, often offering unique advantages in terms of atom economy or for accessing specific substitution patterns.

Direct C-H arylation is a highly attractive strategy as it avoids the pre-functionalization of the naphthalene core. Palladium-catalyzed C8-arylation of 1-amidonaphthalenes using diaryliodonium salts as the arylating agent has been reported with high regioselectivity.[9][10] The amide group acts as a directing group, guiding the arylation to the sterically hindered C8 position.

[4+2] Cycloaddition reactions, such as the Diels-Alder reaction, can be powerful tools for constructing the naphthalene core with pre-defined substitution patterns. For instance, the reaction of an appropriately substituted diene with a dienophile can lead to a dihydronaphthalene precursor that can be subsequently aromatized.[11] An aryne Diels-Alder reaction with a functionalized acyclic diene can also provide a route to substituted dihydronaphthalenes.[11] Rhodium-catalyzed [2+2+2] cycloaddition of 1-alkynyl-8-arylnaphthalenes with diynes has been shown to produce axially chiral 1,8-diarylnaphthalenes with high enantioselectivity.[12]

## Atropisomerism in 1,8-Diarylnaphthalenes: Separation and Characterization

The steric clash between the peri-substituents in 1,8-diarylnaphthalenes often leads to restricted rotation around the aryl-naphthalene bonds, resulting in atropisomerism. When the aryl groups bear ortho or meta substituents, the anti-conformer becomes chiral ( $C_2$ -symmetric), while the syn-isomer is achiral (meso) if the substituents are identical.[1]

Separation of Atropisomers:

The separation of syn and anti atropisomers can often be achieved by standard chromatographic techniques.

- Column Chromatography: For atropisomers with a sufficiently high rotational barrier, separation on silica gel is often possible.
- High-Performance Liquid Chromatography (HPLC): Chiral HPLC is a powerful technique for separating the enantiomers of the anti-conformer. In some cases, even the separation of syn and anti diastereomers can be achieved on an achiral column at low temperatures.[13]

- Preferential Crystallization: In favorable cases, one of the diastereomers may selectively crystallize from a solution, allowing for its separation.[13]

Characterization of Atropisomers:

- Nuclear Magnetic Resonance (NMR) Spectroscopy:  $^1\text{H}$  NMR is a key tool for distinguishing between syn and anti isomers. The different spatial environments of the protons on the aryl and naphthalene rings in the two conformers lead to distinct chemical shifts and coupling patterns. Variable-temperature NMR can be used to study the dynamics of rotation and determine the energy barrier to isomerization.
- Single-Crystal X-ray Diffraction: This technique provides unambiguous proof of the solid-state conformation (syn or anti) and allows for detailed analysis of the bond lengths, bond angles, and dihedral angles, offering insights into the steric strain within the molecule.

## Conclusion and Future Outlook

The synthesis of 1,8-diarylnaphthalenes has been largely enabled by the power and versatility of palladium-catalyzed cross-coupling reactions, particularly the Suzuki-Miyaura and Stille couplings. These methods provide reliable access to a wide range of symmetrical and, with careful planning, unsymmetrical derivatives. The unique structural and photophysical properties arising from the sterically congested peri-substitution continue to drive interest in these molecules for applications in materials science and catalysis.

Future research in this area will likely focus on the development of more efficient and sustainable synthetic methods, such as C-H activation, that avoid the need for pre-functionalized starting materials. The atroposelective synthesis of 1,8-diarylnaphthalenes with high enantiomeric excess remains a significant challenge and an area of active investigation, with the potential to unlock new applications in asymmetric catalysis and chiroptical materials. As our understanding of the structure-property relationships in this fascinating class of molecules grows, so too will the demand for innovative and practical synthetic strategies.

## References

- ResearchGate. (n.d.). Enantioselective Synthesis of Axially Chiral 1,8-Diarylnaphthalenes by Rh-Catalyzed [2 + 2 + 2] Cycloaddition and Evaluation of Their Chiroptical Properties. Retrieved from [\[Link\]](#)

- (n.d.). Spectra data of compounds. Retrieved from [\[Link\]](#)
- Organic Chemistry Portal. (n.d.). Synthesis of Dihydronaphthalenes via Aryne Diels-Alder Reactions: Scope and Diastereoselectivity. Retrieved from [\[Link\]](#)
- PubMed. (2003, September 3). Synthesis of conformationally stable 1,8-diarylnaphthalenes: development of new photoluminescent sensors for ion-selective recognition. Retrieved from [\[Link\]](#)
- PubMed. (n.d.). Palladium-catalyzed formation of highly substituted naphthalenes from arene and alkyne hydrocarbons. Retrieved from [\[Link\]](#)
- ACS Publications. (2010, February 15). Naphthalene Diels–Alder in a Self-Assembled Molecular Flask. Journal of the American Chemical Society. Retrieved from [\[Link\]](#)
- ResearchGate. (n.d.). Suzuki–Miyaura Cross-Coupling of 1,8-Diaminonaphthalene (dan)-Protected Arylboronic Acids. Retrieved from [\[Link\]](#)
- (n.d.). Design and Synthesis of Three Naphthol Derivatives using the Three Component System. Retrieved from [\[Link\]](#)
- (2023, December 11). Chemical Synthesis of Substituted Naphthalene Derivatives: A Review. Retrieved from [\[Link\]](#)
- ResearchGate. (n.d.). Synthesis of 1,8-diphenylnaphthalene using organocopper reagents. Retrieved from [\[Link\]](#)
- ResearchGate. (n.d.). Ullmann synthesis of unsymmetrical 1,8-diarylnaphthalenes. Retrieved from [\[Link\]](#)
- ResearchGate. (n.d.). 1,8-Diarylnaphthalenes: Synthesis, Properties, and Applications. Retrieved from [\[Link\]](#)
- PMC. (2020, November 18). A versatile Diels–Alder approach to functionalized hydroanthraquinones. Retrieved from [\[Link\]](#)

- PubMed. (2025, May 2). Enantioselective Synthesis of Axially Chiral 1,8-Diarylnaphthalenes by Rh-Catalyzed [2 + 2 + 2] Cycloaddition and Evaluation of Their Chiroptical Properties. Retrieved from [[Link](#)]
- PMC. (2016, December 9). Sequential and iterative Pd-catalyzed cross-coupling reactions in organic synthesis. Retrieved from [[Link](#)]
- ResearchGate. (n.d.). Exploring the selectivity of the Suzuki-Miyaura cross-coupling reaction in the synthesis of aryl naphthalenes. Retrieved from [[Link](#)]
- PubMed. (2019, November 13). Palladium-Catalyzed C8-Arylation of Naphthalenes through C-H Activation: A Combined Experimental and Computational Study. Retrieved from [[Link](#)]
- (n.d.). 25. The Grignard Reaction. Retrieved from [[Link](#)]
- ResearchGate. (n.d.). Synthesis of axially chiral 1,8-diarylnaphthalene ligands and application in asymmetric catalysis: An intriguing fluorine effect. Retrieved from [[Link](#)]
- Springer Nature. (2019, October 25). Journal Club | Organic synthesis goes atroposelective. Retrieved from [[Link](#)]
- ResearchGate. (2025, August 9). Palladium-Catalyzed Formation of Highly Substituted Naphthalenes from Arene and Alkyne Hydrocarbons. Retrieved from [[Link](#)]
- Royal Society of Chemistry. (n.d.). Palladium-catalyzed C8-H arylation and annulation of 1-naphthalene carboxylic acid derivatives with aryl iodides. Retrieved from [[Link](#)]
- (n.d.). Grignard Reaction. Retrieved from [[Link](#)]
- Organic Syntheses. (n.d.). 5. Retrieved from [[Link](#)]
- ResearchGate. (n.d.). Palladium-Catalyzed C8-Arylation of Naphthalenes through C-H Activation: A Combined Experimental and Computational Study. Retrieved from [[Link](#)]
- (n.d.). 6. Grignard Reaction. Retrieved from [[Link](#)]
- (n.d.). Suzuki Cross-Coupling of Phenylboronic Acid and 5- Iodovanillin. Retrieved from [[Link](#)]

- PMC. (2024, November 7). Recent Advances in Sequentially Pd-Catalyzed One-Pot Syntheses of Heterocycles. Retrieved from [[Link](#)]
- ResearchGate. (n.d.). Grignard PDF. Retrieved from [[Link](#)]
- MDPI. (n.d.). Photochemical Synthesis and Properties of 1,6- and 1,8-Naphthalenophanes. Retrieved from [[Link](#)]
- Organic Syntheses. (n.d.). and the resulting deep red solution is capped with a glass septum and heated in a silicon oil bath at 100 °C for 48 h under argon atmosphere (Figure 2) ( - Note 5. Retrieved from [[Link](#)]
- Royal Society of Chemistry. (n.d.). Temperature-controlled sequential Suzuki–Miyaura reactions for preparing unsymmetrical terphenyls. Retrieved from [[Link](#)]
- Figshare. (2004, March 19). Synthesis and Stereodynamics of Highly Constrained 1,8-Bis(2,2'-dialkyl-4,4'-diquinolyl)naphthalenes. The Journal of Organic Chemistry. Retrieved from [[Link](#)]
- PubMed. (n.d.). Synthesis and stereodynamics of highly constrained 1,8-bis(2,2'-dialkyl-4,4'-diquinolyl)naphthalenes. Retrieved from [[Link](#)]
- ResearchGate. (n.d.). Direct Suzuki–Miyaura Coupling of Naphthalene-1,8-diaminato (dan)-Substituted Cyclopropylboron Compounds. Retrieved from [[Link](#)]
- Scilit. (n.d.). Single crystal X-ray diffraction studies of aromatic oligomers: resolution of the bond-angle anomaly in poly(aryletherketone)s. Retrieved from [[Link](#)]
- University of Southampton. (n.d.). Solvent-Free Synthesis of Core-Functionalised Naphthalene Diimides by Using a Vibratory Ball Mill: Suzuki, Sonogashira and Buchwald–Hartwig Reactions. Retrieved from [[Link](#)]
- PubMed. (2000, February 25). Separation of isomeric naphthalenesulphonic acids by micro high-performance liquid chromatography with mobile phases containing cyclodextrin. Retrieved from [[Link](#)]

### Need Custom Synthesis?

BenchChem offers custom synthesis for rare earth carbides and specific isotopic labeling.

Email: [info@benchchem.com](mailto:info@benchchem.com) or [Request Quote Online](#).

## Sources

- [1. researchgate.net \[researchgate.net\]](#)
- [2. Synthesis of conformationally stable 1,8-diarylnaphthalenes: development of new photoluminescent sensors for ion-selective recognition - PubMed \[pubmed.ncbi.nlm.nih.gov\]](#)
- [3. researchgate.net \[researchgate.net\]](#)
- [4. pdf.benchchem.com \[pdf.benchchem.com\]](#)
- [5. Temperature-controlled sequential Suzuki–Miyaura reactions for preparing unsymmetrical terphenyls - Organic & Biomolecular Chemistry \(RSC Publishing\) \[pubs.rsc.org\]](#)
- [6. Sequential and iterative Pd-catalyzed cross-coupling reactions in organic synthesis - PMC \[pmc.ncbi.nlm.nih.gov\]](#)
- [7. Recent Advances in Sequentially Pd-Catalyzed One-Pot Syntheses of Heterocycles - PMC \[pmc.ncbi.nlm.nih.gov\]](#)
- [8. researchgate.net \[researchgate.net\]](#)
- [9. Palladium-Catalyzed C8-Arylation of Naphthalenes through C-H Activation: A Combined Experimental and Computational Study - PubMed \[pubmed.ncbi.nlm.nih.gov\]](#)
- [10. researchgate.net \[researchgate.net\]](#)
- [11. Synthesis of Dihydronaphthalenes via Aryne Diels-Alder Reactions: Scope and Diastereoselectivity \[organic-chemistry.org\]](#)
- [12. Enantioselective Synthesis of Axially Chiral 1,8-Diarylnaphthalenes by Rh-Catalyzed \[2 + 2 + 2\] Cycloaddition and Evaluation of Their Chiroptical Properties - PubMed \[pubmed.ncbi.nlm.nih.gov\]](#)
- [13. acs.figshare.com \[acs.figshare.com\]](#)
- To cite this document: BenchChem. [The Synthesis of 1,8-Diarylnaphthalenes: A Comprehensive Technical Guide for Researchers]. BenchChem, [2026]. [Online PDF]. Available at: [<https://www.benchchem.com/product/b094500/docs#the-synthesis-of-1-8-diarylnaphthalenes-a-comprehensive-technical-guide-for-researchers>]

**Disclaimer & Data Validity:**

The information provided in this document is for Research Use Only (RUO) and is strictly not intended for diagnostic or therapeutic procedures. While BenchChem strives to provide accurate protocols, we make no warranties, express or implied, regarding the fitness of this product for every specific experimental setup.

**Technical Support:** The protocols provided are for reference purposes. Unsure if this reagent suits your experiment?

**Need Industrial/Bulk Grade?** [Request Custom Synthesis Quote](#)

## BenchChem

Our mission is to be the trusted global source of essential and advanced chemicals, empowering scientists and researchers to drive progress in science and industry.

### Contact

Address: 3281 E Guasti Rd  
Ontario, CA 91761, United States  
Phone: (601) 213-4426  
Email: [info@benchchem.com](mailto:info@benchchem.com)

[Contact our Ph.D. Support Team for a compatibility check](#)