

Application Notes and Protocols: Synthesis of 4-Anilinoquinazoline Derivatives

Author: BenchChem Technical Support Team. **Date:** December 2025

Compound of Interest

Compound Name: *Quinazoline-4,7-diol*

Cat. No.: *B093651*

[Get Quote](#)

For Researchers, Scientists, and Drug Development Professionals

Introduction

4-Anilinoquinazoline derivatives are a significant class of heterocyclic compounds widely recognized for their potent biological activities, particularly as kinase inhibitors. Many compounds based on this scaffold have been developed as targeted cancer therapeutics, most notably as inhibitors of the Epidermal Growth Factor Receptor (EGFR) tyrosine kinase.^[1] The overexpression or mutation of EGFR is a key factor in the progression of various cancers, making it a crucial target for drug development.^{[1][2]} This document provides a detailed protocol for the synthesis of 4-anilinoquinazoline derivatives, focusing on a common and efficient microwave-assisted method.

Signaling Pathway of 4-Anilinoquinazoline Derivatives

The primary mechanism of action for many biologically active 4-anilinoquinazoline derivatives is the inhibition of the EGFR signaling pathway.^{[1][2][3][4]} EGFR activation, typically by ligands such as EGF, leads to a cascade of downstream signaling events that promote cell proliferation, growth, and metastasis.^[2] 4-Anilinoquinazoline compounds act as ATP-competitive inhibitors, binding to the kinase domain of EGFR and preventing its autophosphorylation and the subsequent activation of downstream pathways like the RAS/MAPK and PI3K/AKT pathways.

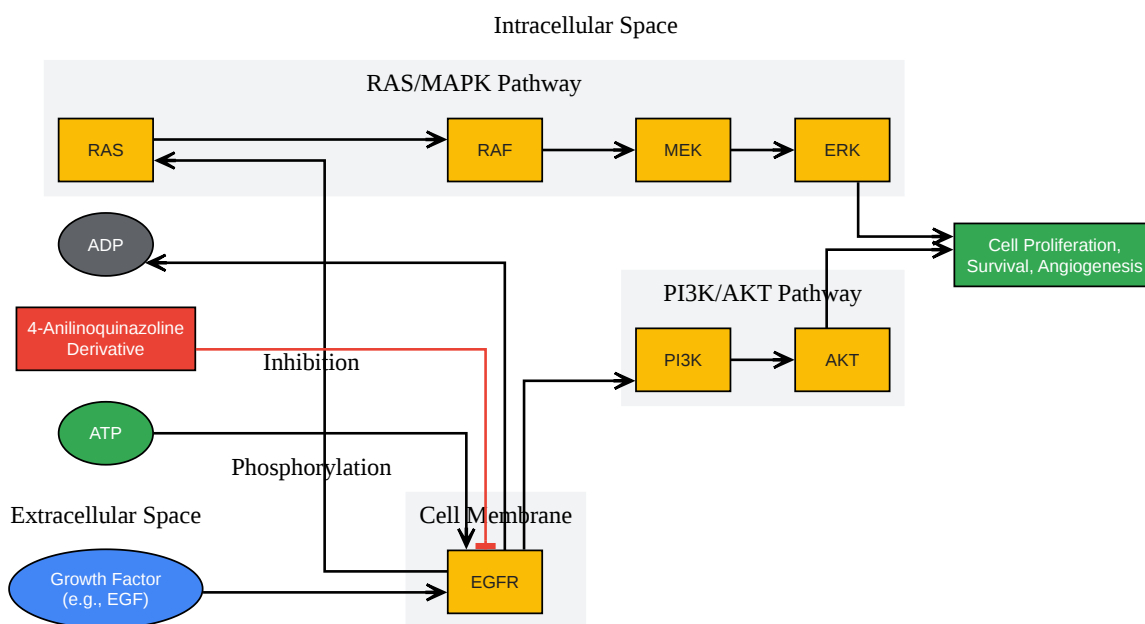

[Click to download full resolution via product page](#)

Caption: EGFR signaling pathway and the inhibitory action of 4-anilinoquinazoline derivatives.

Experimental Protocols

A prevalent and efficient method for synthesizing 4-anilinoquinazoline derivatives involves the nucleophilic substitution of a 4-chloroquinazoline with a substituted aniline.[5][6] Microwave-assisted synthesis has emerged as a superior alternative to classical heating methods, offering significantly reduced reaction times and often improved yields.[5][7]

General Workflow for Synthesis

The synthesis of 4-anilinoquinazoline derivatives typically follows a straightforward workflow, beginning with the preparation of the quinazoline core, followed by chlorination and subsequent

amination.

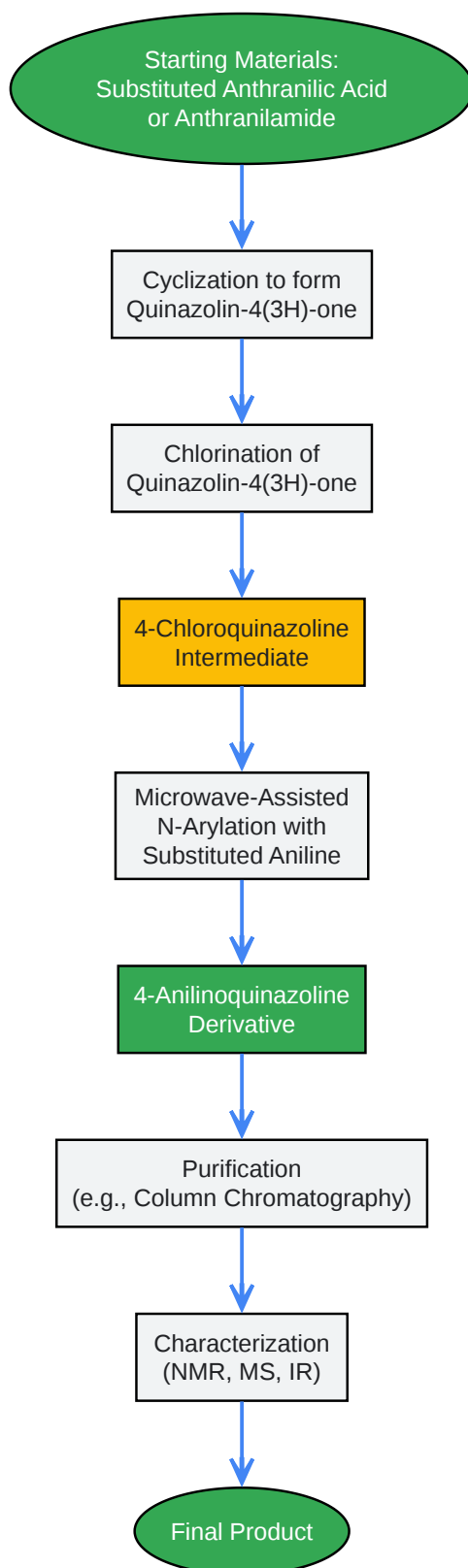

[Click to download full resolution via product page](#)

Caption: General workflow for the synthesis of 4-anilinoquinazoline derivatives.

Microwave-Assisted Synthesis of N-Aryl-4-aminoquinazoline Derivatives

This protocol is adapted from a general method for the synthesis of various N-aryl substituted 4-aminoquinazoline compounds.[5]

Materials:

- 4-Chloroquinazoline
- Substituted aryl heterocyclic amine
- 2-Propanol (IPA)
- Microwave reactor

Procedure:

- In a microwave-safe reaction vessel, combine 4-chloroquinazoline (1.0 mmol) and the desired substituted aniline (1.2 mmol).
- Add 2-propanol (5 mL) as the solvent.
- Seal the vessel and place it in the microwave reactor.
- Irradiate the reaction mixture at a constant power of 60W for 20 minutes.[5] The reaction temperature will typically reach the reflux temperature of 2-propanol.
- After the reaction is complete, allow the vessel to cool to room temperature.
- The resulting solid product can be collected by filtration.
- Wash the collected solid with cold 2-propanol to remove any unreacted starting materials.
- Dry the product under vacuum.

- If necessary, further purify the product by column chromatography on silica gel.

Data Presentation

The use of microwave irradiation significantly accelerates the reaction compared to classical heating methods. The following table summarizes the reaction conditions and yields for the synthesis of various N-arylheterocyclic substituted-4-aminoquinazoline derivatives using the microwave-assisted protocol.

Compound	Aniline Derivative	Reaction Time (Microwave)	Yield (%) (Microwave)	Reaction Time (Classical)	Yield (%) (Classical)
5a	2-aminopyridine	20 min	95.2	12 h	35.1
5b	2-amino-5-bromopyridine	20 min	96.5	12 h	37.3
5c	2-amino-5-chloropyridine	20 min	98.1	12 h	36.4
5d	2-amino-5-iodopyridine	20 min	95.8	12 h	33.2
5e	2-amino-5-methylpyridine	20 min	97.4	12 h	38.5
5f	2-amino-3-picoline	20 min	96.2	12 h	36.8
5g	2-aminopyrimidine	20 min	98.3	12 h	40.1

Data adapted from a study on microwave-assisted synthesis of N-arylheterocyclic substituted-4-aminoquinazoline derivatives.[5]

The following table demonstrates the effect of microwave power and temperature on the yield of a representative compound (5b).

Entry	Microwave Power (W)	Temperature (°C)	Time (min)	Yield (%)
1	0 (Classical)	80	720	37.3
2	60	80	10	96.5
3	40	80	10	75.9
4	80	80	10	98.8
5	100	80	10	97.0
6	60	30	10	79.9
7	60	50	10	84.0
8	60	70	10	90.0

Data adapted from a study on microwave-assisted synthesis of N-arylheterocyclic substituted-4-aminoquinazoline derivatives.[5]

Conclusion

The synthesis of 4-anilinoquinazoline derivatives is a critical process in the development of novel therapeutic agents. The provided microwave-assisted protocol offers a rapid, efficient, and high-yielding method for obtaining these valuable compounds. The straightforward nature of this protocol makes it accessible to a wide range of researchers in the fields of medicinal chemistry and drug discovery. The ability of these compounds to inhibit key signaling pathways, such as the EGFR pathway, underscores their therapeutic potential and the importance of continued research in this area.

Need Custom Synthesis?

BenchChem offers custom synthesis for rare earth carbides and specific isotopic labeling.

Email: info@benchchem.com or [Request Quote Online](#).

References

- 1. 4-Anilinoquinazoline Derivatives with Epidermal Growth Factor Receptor Inhibitor Activity - PubMed [pubmed.ncbi.nlm.nih.gov]
- 2. Design and Modeling of 4-Anilinoquinazoline Derivatives as Small Molecule Inhibitors of T790M/C797S EGFR Mutations to Abandon the Phenomenon of Tumor Angiogenesis [openbioinformaticsjournal.com]
- 3. Discovery and optimization of 4-anilinoquinazoline derivatives spanning ATP binding site and allosteric site as effective EGFR-C797S inhibitors - PubMed [pubmed.ncbi.nlm.nih.gov]
- 4. Discovery of novel 4-anilinoquinazoline derivatives as potent inhibitors of epidermal growth factor receptor with antitumor activity - PubMed [pubmed.ncbi.nlm.nih.gov]
- 5. Microwave Assisted Synthesis of N-Arylheterocyclic Substituted-4-aminoquinazoline Derivatives - PMC [pmc.ncbi.nlm.nih.gov]
- 6. pdfs.semanticscholar.org [pdfs.semanticscholar.org]
- 7. Microwave assisted synthesis of N-arylheterocyclic substituted-4-aminoquinazoline derivatives - PubMed [pubmed.ncbi.nlm.nih.gov]
- To cite this document: BenchChem. [Application Notes and Protocols: Synthesis of 4-Anilinoquinazoline Derivatives]. BenchChem, [2025]. [Online PDF]. Available at: [https://www.benchchem.com/product/b093651#lab-protocol-for-the-synthesis-of-4-anilinoquinazoline-derivatives]

Disclaimer & Data Validity:

The information provided in this document is for Research Use Only (RUO) and is strictly not intended for diagnostic or therapeutic procedures. While BenchChem strives to provide accurate protocols, we make no warranties, express or implied, regarding the fitness of this product for every specific experimental setup.

Technical Support: The protocols provided are for reference purposes. Unsure if this reagent suits your experiment? [[Contact our Ph.D. Support Team for a compatibility check](#)]

Need Industrial/Bulk Grade? [Request Custom Synthesis Quote](#)

BenchChem

Our mission is to be the trusted global source of essential and advanced chemicals, empowering scientists and researchers to drive progress in science and industry.

Contact

Address: 3281 E Guasti Rd

Ontario, CA 91761, United States

Phone: (601) 213-4426

Email: info@benchchem.com