

# Spectroscopic Profile of 2-Nitrobenzohydrazide: A Technical Guide

**Author:** BenchChem Technical Support Team. **Date:** May 2026

## Compound of Interest

Compound Name:	2-Nitrobenzohydrazide
CAS No.:	606-26-8
Cat. No.:	B091997

[Get Quote](#)

For Researchers, Scientists, and Drug Development Professionals

This technical guide provides a detailed overview of the expected spectroscopic data for **2-Nitrobenzohydrazide**. Due to the limited availability of published experimental spectra for this specific compound in public databases, this document presents a comprehensive analysis based on data from its isomers and structurally related molecules. This information is intended to serve as a valuable reference for the identification, characterization, and quality control of **2-Nitrobenzohydrazide** in research and development settings.

## Predicted Spectroscopic Data

The following tables summarize the predicted nuclear magnetic resonance (NMR), infrared (IR), and mass spectrometry (MS) data for **2-Nitrobenzohydrazide**. These predictions are derived from the analysis of known data for 3-nitrobenzohydrazide, 4-nitrobenzohydrazide, 2-nitrobenzamide, and other related structures.

## Nuclear Magnetic Resonance (NMR) Spectroscopy

Table 1: Predicted <sup>1</sup>H NMR Spectral Data for **2-Nitrobenzohydrazide**

Chemical Shift ( $\delta$ , ppm)	Multiplicity	Integration	Assignment
~7.6 - 7.9	Multiplet	4H	Aromatic Protons (C <sub>3</sub> -H, C <sub>4</sub> -H, C <sub>5</sub> -H, C <sub>6</sub> -H)
~4.5 - 5.0	Broad Singlet	2H	-NH <sub>2</sub>
~9.5 - 10.0	Singlet	1H	-NH-

Solvent: DMSO-d<sub>6</sub>

Table 2: Predicted <sup>13</sup>C NMR Spectral Data for **2-Nitrobenzohydrazide**

Chemical Shift ( $\delta$ , ppm)	Assignment
~165	C=O
~148	C-NO <sub>2</sub>
~133	Aromatic CH
~130	Aromatic C-C=O
~129	Aromatic CH
~124	Aromatic CH
~122	Aromatic CH

Solvent: DMSO-d<sub>6</sub>

## Infrared (IR) Spectroscopy

Table 3: Predicted FT-IR Spectral Data for **2-Nitrobenzohydrazide**

Wavenumber (cm <sup>-1</sup> )	Intensity	Assignment
3300 - 3400	Strong, Broad	N-H Stretching (asymmetric and symmetric)
~3050	Medium	Aromatic C-H Stretching
~1660	Strong	C=O Stretching (Amide I)
~1600	Medium	N-H Bending (Amide II)
~1520	Strong	Asymmetric NO <sub>2</sub> Stretching
~1340	Strong	Symmetric NO <sub>2</sub> Stretching
~1300	Medium	C-N Stretching
700 - 900	Medium-Strong	Aromatic C-H Bending (out-of-plane)

Sample Preparation: KBr pellet

## Mass Spectrometry (MS)

Table 4: Predicted Mass Spectrometry Data for **2-Nitrobenzohydrazide**

m/z	Relative Intensity	Assignment
181	High	[M] <sup>+</sup> (Molecular Ion)
151	Medium	[M - NH <sub>2</sub> NH] <sup>+</sup>
150	High	[M - NH <sub>2</sub> NH <sub>2</sub> ] <sup>+</sup>
134	Medium	[M - NO <sub>2</sub> ] <sup>+</sup>
122	Medium	[C <sub>7</sub> H <sub>6</sub> O <sub>2</sub> ] <sup>+</sup>
104	Medium	[C <sub>7</sub> H <sub>4</sub> O] <sup>+</sup>
92	Medium	[C <sub>6</sub> H <sub>4</sub> O] <sup>+</sup>
76	High	[C <sub>6</sub> H <sub>4</sub> ] <sup>+</sup>

Ionization Method: Electron Ionization (EI)

## Experimental Protocols

The following are generalized experimental protocols for obtaining the spectroscopic data presented above. Instrument-specific parameters may require optimization.

### Nuclear Magnetic Resonance (NMR) Spectroscopy

- Sample Preparation: Dissolve approximately 5-10 mg of **2-Nitrobenzohydrazide** in 0.5-0.7 mL of deuterated dimethyl sulfoxide (DMSO- $d_6$ ).
- Internal Standard: Add a small amount of tetramethylsilane (TMS) as an internal standard ( $\delta$  0.00 ppm).
- Data Acquisition:
  - Acquire  $^1\text{H}$  NMR spectra on a 300 MHz or higher field NMR spectrometer.
  - Acquire  $^{13}\text{C}$  NMR spectra on the same instrument, typically at a frequency of 75 MHz.
- Data Processing: Process the raw data using appropriate software to perform Fourier transformation, phase correction, and baseline correction.

### Fourier-Transform Infrared (FT-IR) Spectroscopy

- Sample Preparation (KBr Pellet Method):
  - Thoroughly grind 1-2 mg of **2-Nitrobenzohydrazide** with approximately 100-200 mg of dry potassium bromide (KBr) powder using an agate mortar and pestle.
  - Place the mixture in a pellet press and apply pressure to form a thin, transparent pellet.
- Data Acquisition:
  - Record a background spectrum of the empty sample compartment.
  - Place the KBr pellet in the sample holder and record the sample spectrum over a range of 4000-400  $\text{cm}^{-1}$ .

- **Data Processing:** The instrument software will automatically subtract the background spectrum from the sample spectrum to produce the final IR spectrum.

## Mass Spectrometry (MS)

- **Sample Introduction:** Introduce a small amount of **2-Nitrobenzohydrazide** into the mass spectrometer, typically via a direct insertion probe for solid samples or after separation by gas chromatography.
- **Ionization:** Utilize electron ionization (EI) at a standard energy of 70 eV to generate the molecular ion and fragment ions.
- **Mass Analysis:** The ions are separated based on their mass-to-charge ratio ( $m/z$ ) by a mass analyzer (e.g., a quadrupole or time-of-flight analyzer).
- **Detection:** The abundance of each ion is measured by a detector, and the resulting data is plotted as a mass spectrum.

## Visualizations

The following diagrams illustrate the general workflow for spectroscopic analysis and a predicted fragmentation pathway for **2-Nitrobenzohydrazide** in mass spectrometry.

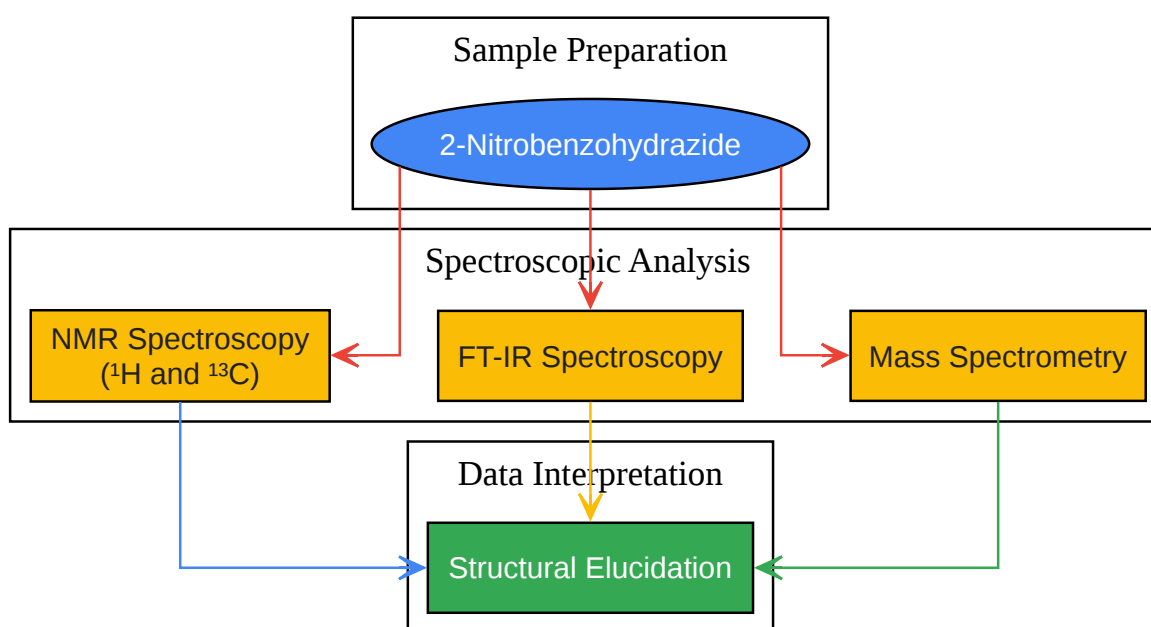

[Click to download full resolution via product page](#)

### Spectroscopic analysis workflow for **2-Nitrobenzohydrazide**.

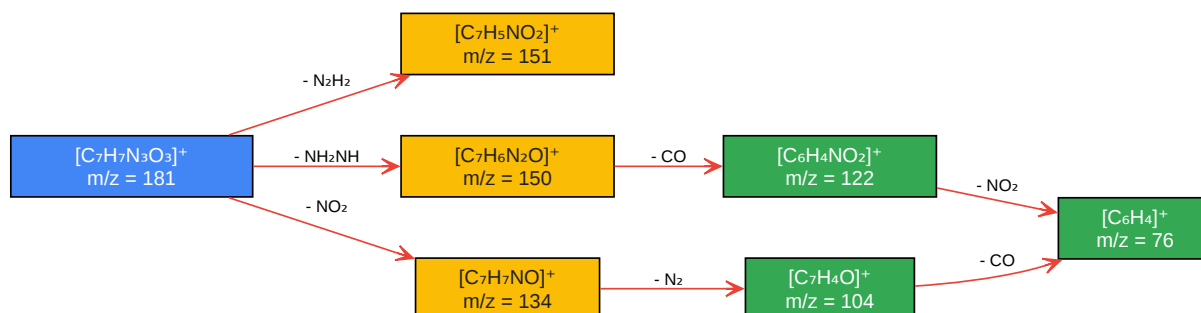

[Click to download full resolution via product page](#)

### Predicted fragmentation of **2-Nitrobenzohydrazide** in MS.

- To cite this document: BenchChem. [Spectroscopic Profile of 2-Nitrobenzohydrazide: A Technical Guide]. BenchChem, [2026]. [Online PDF]. Available at: [\[https://www.benchchem.com/product/b091997/docs#spectroscopic-profile-of-2-nitrobenzohydrazide-a-technical-guide\]](https://www.benchchem.com/product/b091997/docs#spectroscopic-profile-of-2-nitrobenzohydrazide-a-technical-guide)

#### Disclaimer & Data Validity:

The information provided in this document is for Research Use Only (RUO) and is strictly not intended for diagnostic or therapeutic procedures. While BenchChem strives to provide accurate protocols, we make no warranties, express or implied, regarding the fitness of this product for every specific experimental setup.

**Technical Support:** The protocols provided are for reference purposes. Unsure if this reagent suits your experiment?

**Need Industrial/Bulk Grade?** [Request Custom Synthesis Quote](#)

# BenchChem

Our mission is to be the trusted global source of essential and advanced chemicals, empowering scientists and researchers to drive progress in science and industry.

## Contact

Address: 3281 E Guasti Rd

Ontario, CA 91761, United States

Phone: (601) 213-4426

Email: [info@benchchem.com](mailto:info@benchchem.com)

[Contact our Ph.D. Support Team for a compatibility check](#)