

HPLC method for determining 2,5,6-trimethylbenzoxazole purity

Author: BenchChem Technical Support Team. **Date:** December 2025

Compound of Interest

Compound Name: 2,5,6-Trimethylbenzoxazole

Cat. No.: B090905

[Get Quote](#)

An Application Note on the Determination of **2,5,6-Trimethylbenzoxazole** Purity via High-Performance Liquid Chromatography

Introduction

2,5,6-Trimethylbenzoxazole is a heterocyclic compound of interest in medicinal chemistry and materials science. As with any synthesized chemical entity intended for research or development, establishing its purity is a critical quality control step. High-Performance Liquid Chromatography (HPLC) is a precise and reliable analytical technique for purity assessment, capable of separating the main compound from its impurities.^[1]

This application note details a reverse-phase HPLC (RP-HPLC) method for the quantitative determination of the purity of **2,5,6-trimethylbenzoxazole**. The described protocol is designed for researchers, scientists, and drug development professionals who require a robust method for assessing the purity of this compound and similar benzoxazole derivatives.

Materials and Methods

The method was developed based on established principles for the analysis of related heterocyclic compounds.^{[1][2][3]}

Instrumentation and Chromatographic Conditions

A standard HPLC system equipped with a UV detector is suitable for this analysis. The parameters outlined in Table 1 provide a starting point for method development and validation.

Table 1: HPLC Instrumentation and Conditions

Parameter	Specification
HPLC System	Quaternary Pump, Autosampler, Column Oven, UV/Vis Detector
Column	C18 Reverse-Phase Column (e.g., 4.6 x 150 mm, 5 µm)
Mobile Phase A	0.1% Phosphoric Acid in Water
Mobile Phase B	Acetonitrile
Gradient Elution	See Table 2
Flow Rate	1.0 mL/min
Column Temperature	30 °C
Detection Wavelength	288 nm
Injection Volume	10 µL
Run Time	25 minutes

Reagents and Sample Preparation

- Acetonitrile (ACN): HPLC Grade
- Water: HPLC Grade or Ultrapure Water
- Phosphoric Acid (H₃PO₄): Analytical Grade
- **2,5,6-Trimethylbenzoxazole**: Reference Standard (>98.0% purity) and sample for analysis. [\[4\]](#)[\[5\]](#)
- Methanol: HPLC Grade (for sample dissolution)

Gradient Elution Program

A gradient elution is employed to ensure the effective separation of **2,5,6-trimethylbenzoxazole** from potential impurities with different polarities.

Table 2: Gradient Elution Profile

Time (minutes)	Mobile Phase A (%)	Mobile Phase B (%)
0.0	70	30
15.0	10	90
20.0	10	90
20.1	70	30
25.0	70	30

Experimental Protocols

Protocol 1: Standard Solution Preparation

- Stock Solution (1 mg/mL): Accurately weigh approximately 10 mg of the **2,5,6-trimethylbenzoxazole** reference standard into a 10 mL volumetric flask.
- Dissolve the standard in methanol and sonicate for 5 minutes to ensure complete dissolution.
- Bring the flask to volume with methanol and mix thoroughly.
- Working Standard (0.1 mg/mL): Pipette 1 mL of the stock solution into a 10 mL volumetric flask.
- Dilute to volume with the initial mobile phase mixture (70% A / 30% B) and mix well.
- Filter the solution through a 0.45 µm syringe filter into an HPLC vial before injection.[1]

Protocol 2: Sample Solution Preparation

- Sample Stock (1 mg/mL): Accurately weigh approximately 10 mg of the **2,5,6-trimethylbenzoxazole** sample to be tested into a 10 mL volumetric flask.

- Dissolve the sample in methanol, using sonication if necessary.
- Dilute to volume with methanol and mix.
- Sample Working Solution (0.1 mg/mL): Transfer 1 mL of the sample stock solution to a 10 mL volumetric flask.
- Dilute to volume with the initial mobile phase mixture and mix thoroughly.
- Filter the final solution through a 0.45 µm syringe filter into an HPLC vial for analysis.[1]

Protocol 3: Data Analysis and Purity Calculation

- Inject the prepared working standard and sample solutions into the HPLC system.
- Identify the peak for **2,5,6-trimethylbenzoxazole** in the sample chromatogram by comparing its retention time with that of the reference standard.
- Integrate all peaks in the sample chromatogram, excluding solvent front peaks.
- Calculate the purity of the sample using the area percent method as described in the equation below.

$$\text{Purity (\%)} = (\text{Area of Main Peak} / \text{Total Area of All Peaks}) \times 100[1]$$

Method Validation Parameters

For routine quality control, the method should be validated according to established guidelines. Key validation parameters are summarized below.

Table 3: Method Validation Summary

Parameter	Specification
Linearity	Correlation coefficient (r^2) ≥ 0.999 over a concentration range of 0.01 - 0.2 mg/mL.[6]
Precision (RSD)	Repeatability (n=6 injections): $\leq 1.0\%$ Intermediate Precision (different days/analysts): $\leq 2.0\%$
Accuracy (% Recovery)	98.0% - 102.0% for spiked samples at three concentration levels.[6]
Limit of Detection (LOD)	Signal-to-Noise ratio of 3:1
Limit of Quantitation (LOQ)	Signal-to-Noise ratio of 10:1
Specificity	The peak for 2,5,6-trimethylbenzoxazole should be well-resolved from any impurity peaks and placebo components.

Visualizations

Experimental Workflow

The logical flow for determining the purity of a **2,5,6-trimethylbenzoxazole** sample is illustrated below.

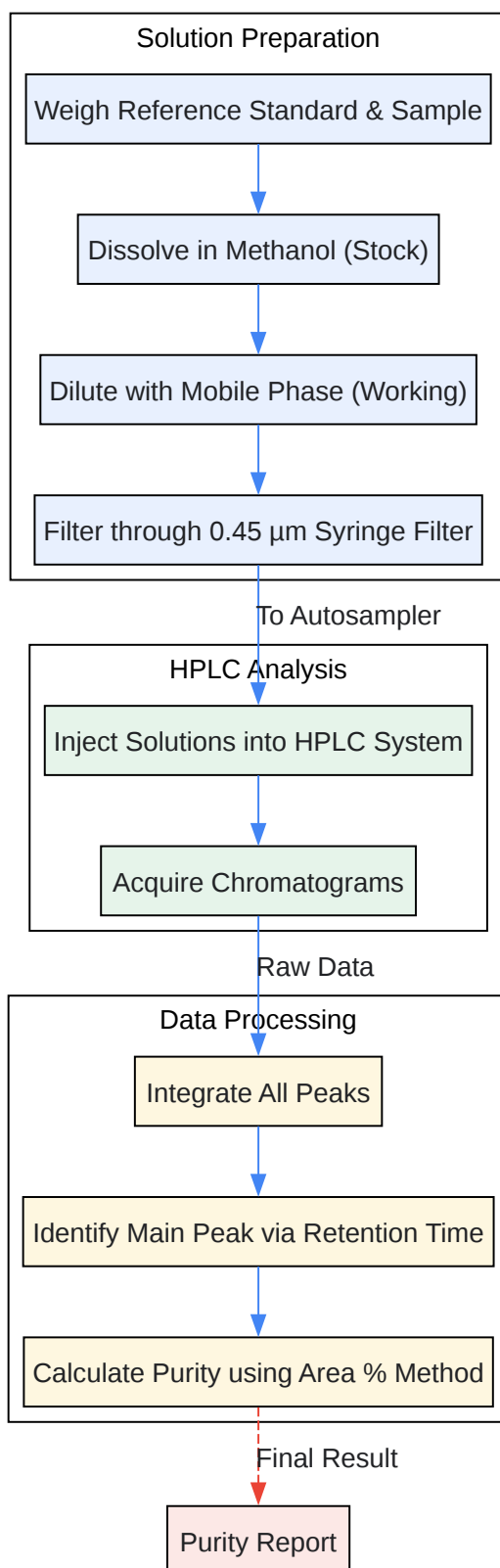

[Click to download full resolution via product page](#)

Caption: Workflow for HPLC Purity Analysis of **2,5,6-Trimethylbenzoxazole**.

Logical Relationship of Method Components

The relationship between the core components of the analytical method is depicted in the following diagram.

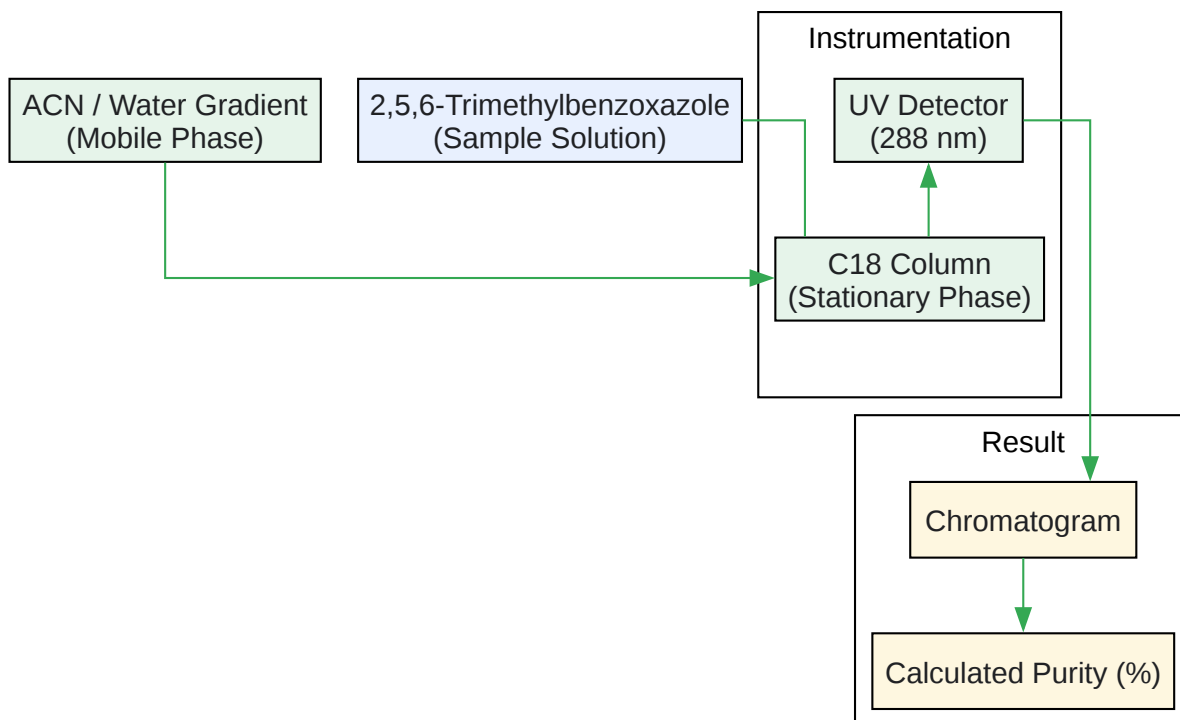

[Click to download full resolution via product page](#)

Caption: Interrelation of Key Components in the HPLC Method.

Need Custom Synthesis?

BenchChem offers custom synthesis for rare earth carbides and specific isotopic labeling.

Email: info@benchchem.com or [Request Quote Online](#).

References

- 1. [benchchem.com](https://www.benchchem.com) [[benchchem.com](https://www.benchchem.com)]
- 2. Separation of Benzoxazole on Newcrom R1 HPLC column | SIELC Technologies [[sielc.com](https://www.sielc.com)]
- 3. [ptfarm.pl](https://www.ptfarm.pl) [[ptfarm.pl](https://www.ptfarm.pl)]
- 4. 2,5,6-Trimethylbenzoxazole | 19219-98-8 | TCI AMERICA [[tcichemicals.com](https://www.tcichemicals.com)]
- 5. 2,5,6-Trimethylbenzoxazole | CymitQuimica [[cymitquimica.com](https://www.cymitquimica.com)]
- 6. [researchgate.net](https://www.researchgate.net) [[researchgate.net](https://www.researchgate.net)]
- To cite this document: BenchChem. [HPLC method for determining 2,5,6-trimethylbenzoxazole purity]. BenchChem, [2025]. [Online PDF]. Available at: [<https://www.benchchem.com/product/b090905#hplc-method-for-determining-2-5-6-trimethylbenzoxazole-purity>]

Disclaimer & Data Validity:

The information provided in this document is for Research Use Only (RUO) and is strictly not intended for diagnostic or therapeutic procedures. While BenchChem strives to provide accurate protocols, we make no warranties, express or implied, regarding the fitness of this product for every specific experimental setup.

Technical Support: The protocols provided are for reference purposes. Unsure if this reagent suits your experiment? [[Contact our Ph.D. Support Team for a compatibility check](#)]

Need Industrial/Bulk Grade? [Request Custom Synthesis Quote](#)

BenchChem

Our mission is to be the trusted global source of essential and advanced chemicals, empowering scientists and researchers to drive progress in science and industry.

Contact

Address: 3281 E Guasti Rd

Ontario, CA 91761, United States

Phone: (601) 213-4426

Email: info@benchchem.com