

Application Notes and Protocols for the Functionalization of 5-Carboxyoxindole

Author: BenchChem Technical Support Team. **Date:** May 2026

Compound of Interest

Compound Name: 5-Carboxyoxindole

CAS No.: 102359-00-2

Cat. No.: B009593

[Get Quote](#)

For Researchers, Scientists, and Drug Development Professionals

Authored by a Senior Application Scientist

The **5-carboxyoxindole** scaffold is a cornerstone in medicinal chemistry, forming the structural core of numerous therapeutic agents and biologically active molecules.^{[1][2]} Its inherent functionalities—a carboxylic acid, a lactam, and an aromatic ring—offer multiple handles for chemical modification, enabling the systematic exploration of chemical space to optimize pharmacological properties. This guide provides a detailed exploration of key experimental protocols for the functionalization of **5-carboxyoxindole**, emphasizing the rationale behind procedural choices to ensure reproducibility and success.

Strategic Importance of 5-Carboxyoxindole in Drug Discovery

The oxindole core is a "privileged scaffold," meaning it is a molecular framework that can bind to multiple, unrelated biological targets.^[3] This versatility has led to the development of drugs for a range of diseases. For instance, derivatives of this scaffold are used in the treatment of

Parkinson's disease, schizophrenia, and other neurological disorders.[1] The carboxylic acid at the 5-position provides a crucial anchor point for introducing a wide variety of substituents, allowing for the fine-tuning of a compound's solubility, lipophilicity, and target engagement.

Amide Bond Formation: The Workhorse Reaction

Amide coupling is one of the most frequently employed reactions in drug discovery, and for good reason: the resulting amide bond is metabolically stable and can participate in key hydrogen bonding interactions with biological targets.[4] The general approach involves the activation of the carboxylic acid of **5-carboxyoxindole** to facilitate nucleophilic attack by an amine.

Conceptual Workflow for Amide Coupling

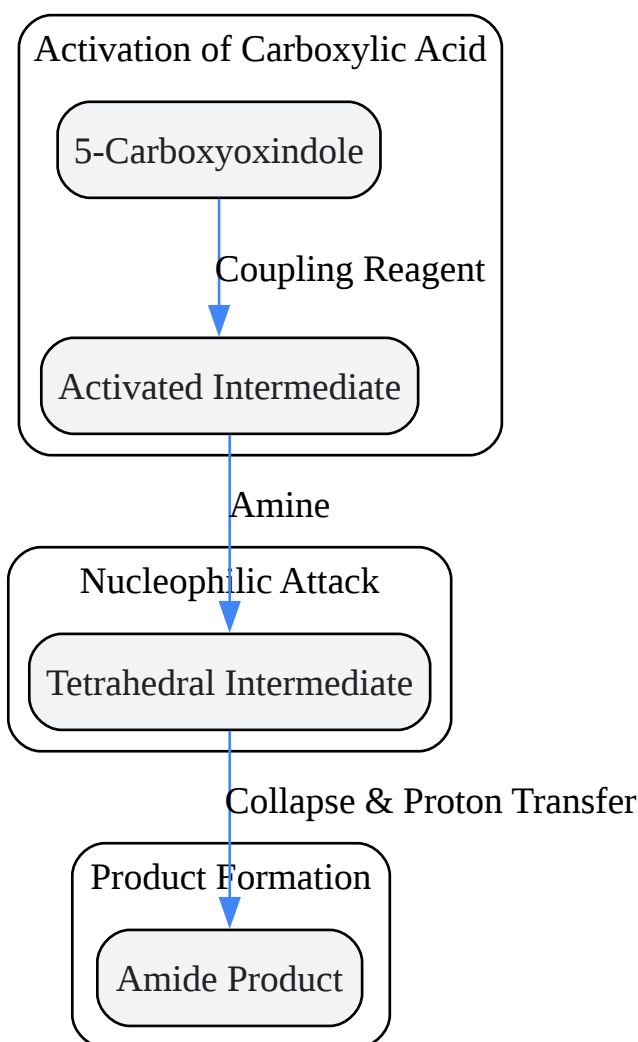

[Click to download full resolution via product page](#)

Caption: General workflow for amide bond formation.

Protocol 2.1: Standard Amide Coupling Using HATU

This protocol utilizes HATU (1-[Bis(dimethylamino)methylene]-1H-1,2,3-triazolo[4,5-b]pyridinium 3-oxid hexafluorophosphate), a common and efficient coupling reagent.

Rationale: HATU is a preferred coupling reagent due to its high efficiency, low propensity for racemization of chiral amines, and the formation of water-soluble byproducts that are easily removed during workup. The addition of a non-nucleophilic base like DIPEA (N,N-Diisopropylethylamine) is crucial to neutralize the hexafluorophosphate salt and to deprotonate the amine, enhancing its nucleophilicity.

Step-by-Step Protocol:

- Preparation: In a clean, dry round-bottom flask, dissolve **5-carboxyoxindole** (1 equivalent) in anhydrous DMF (dimethylformamide).
- Activation: Add HATU (1.1 equivalents) and DIPEA (2.5 equivalents) to the solution. Stir the mixture at room temperature for 15-30 minutes. The formation of the activated ester can be monitored by thin-layer chromatography (TLC).
- Amine Addition: Add the desired amine (1.2 equivalents) to the reaction mixture.
- Reaction: Stir the reaction at room temperature for 2-12 hours. Monitor the progress of the reaction by TLC or LC-MS (Liquid Chromatography-Mass Spectrometry).
- Workup: Once the reaction is complete, pour the mixture into water and extract the product with an organic solvent such as ethyl acetate.
- Purification: Wash the combined organic layers with brine, dry over anhydrous sodium sulfate, and concentrate under reduced pressure. The crude product can be purified by flash column chromatography on silica gel.

Reagent	Equivalents	Purpose
5-Carboxyoxindole	1.0	Starting material
HATU	1.1	Coupling reagent (activates acid)
DIPEA	2.5	Non-nucleophilic base
Amine	1.2	Nucleophile
Anhydrous DMF	-	Aprotic polar solvent

Esterification: Modulating Physicochemical Properties

Esterification of the 5-carboxy group is a valuable strategy for increasing a compound's lipophilicity and potentially improving its cell permeability, which can be beneficial for oral bioavailability.

Protocol 3.1: Fischer-Speier Esterification

This classic method involves the reaction of the carboxylic acid with an alcohol in the presence of a strong acid catalyst.^{[5][6]}

Rationale: The acid catalyst protonates the carbonyl oxygen of the carboxylic acid, making the carbonyl carbon more electrophilic and susceptible to nucleophilic attack by the alcohol.^[5] The reaction is an equilibrium process, so it is often necessary to remove water as it is formed to drive the reaction to completion.^[6]

Step-by-Step Protocol:

- Preparation: Suspend **5-carboxyoxindole** (1 equivalent) in the desired alcohol (e.g., methanol, ethanol), which will serve as both the reactant and the solvent.
- Catalyst Addition: Carefully add a catalytic amount of a strong acid, such as concentrated sulfuric acid (H₂SO₄) or hydrochloric acid (HCl), to the suspension.

- **Reaction:** Heat the mixture to reflux and stir for 4-24 hours. Monitor the reaction's progress by TLC.
- **Workup:** After the reaction is complete, cool the mixture to room temperature and remove the excess alcohol under reduced pressure.
- **Neutralization and Extraction:** Dissolve the residue in an organic solvent like ethyl acetate and wash with a saturated aqueous solution of sodium bicarbonate (NaHCO_3) to neutralize the acid catalyst, followed by washing with brine.
- **Purification:** Dry the organic layer over anhydrous sodium sulfate, filter, and concentrate in vacuo. The crude ester can be purified by recrystallization or column chromatography.

Reagent	Amount	Purpose
5-Carboxyoxindole	1.0 equivalent	Starting material
Alcohol (e.g., MeOH)	Excess (solvent)	Reactant and solvent
Concentrated H_2SO_4	Catalytic	Acid catalyst

Palladium-Catalyzed Cross-Coupling: Building Molecular Complexity

Palladium-catalyzed cross-coupling reactions, such as the Suzuki-Miyaura coupling, are powerful tools for forming carbon-carbon bonds and introducing aryl or heteroaryl moieties.[7] To perform a Suzuki coupling on **5-carboxyoxindole**, it must first be converted to a halide or triflate. Alternatively, a decarboxylative coupling approach can be employed.[8][9]

Protocol 4.1: Decarboxylative Suzuki-Miyaura Coupling

This innovative method allows for the direct coupling of the carboxylic acid with a boronic acid, avoiding the need for pre-functionalization to a halide.[8][9]

Rationale: This reaction proceeds through a palladium-catalyzed cycle where the carboxylic acid undergoes decarboxylation to form an organopalladium intermediate, which then participates in the cross-coupling with the boronic acid.[8]

Step-by-Step Protocol:

- Preparation: In a Schlenk tube, combine **5-carboxyoxindole** (1 equivalent), the desired arylboronic acid (1.5 equivalents), a palladium catalyst such as Pd(OAc)₂ (5 mol%), and a ligand like SPhos (10 mol%).
- Reagent Addition: Add a base, such as K₂CO₃ (2 equivalents), and a silver salt, like Ag₂CO₃ (1.5 equivalents), which acts as an oxidant.
- Solvent and Degassing: Add a suitable solvent, such as dioxane, and degas the mixture by bubbling argon through it for 15-20 minutes.
- Reaction: Heat the reaction mixture at 80-110 °C for 12-24 hours under an inert atmosphere. Monitor the reaction by LC-MS.
- Workup: Cool the reaction to room temperature and filter through a pad of Celite to remove the palladium catalyst and inorganic salts.
- Purification: Concentrate the filtrate and purify the residue by column chromatography to obtain the desired biaryl product.

Reagent	Equivalents/Amount	Purpose
5-Carboxyoxindole	1.0	Starting material
Arylboronic Acid	1.5	Coupling partner
Pd(OAc) ₂	5 mol%	Palladium catalyst
SPhos	10 mol%	Ligand
K ₂ CO ₃	2.0	Base
Ag ₂ CO ₃	1.5	Oxidant
Dioxane	-	Solvent

Suzuki Coupling Reaction Mechanism

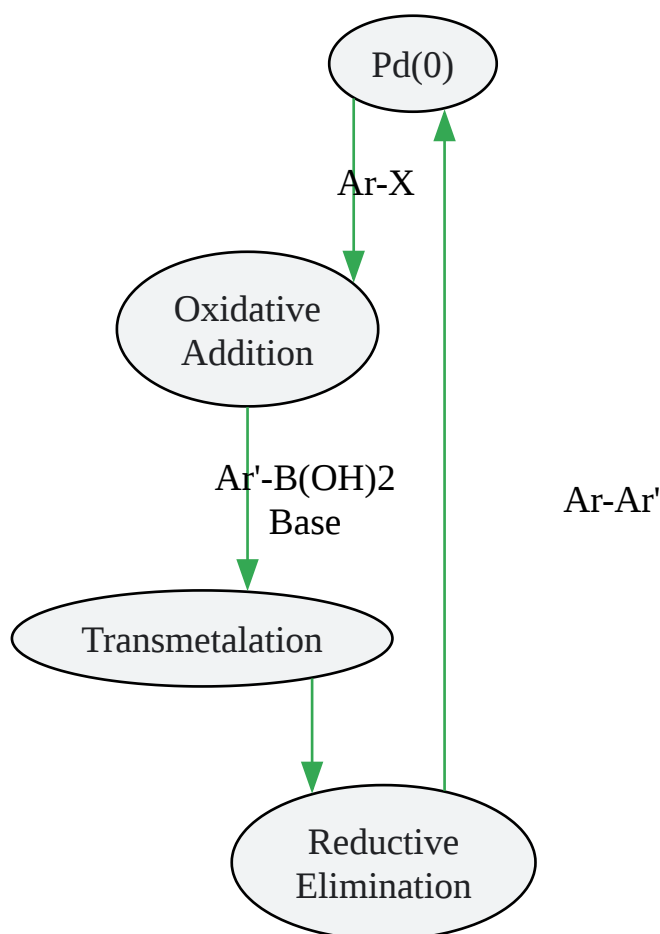

[Click to download full resolution via product page](#)

Caption: Simplified catalytic cycle for the Suzuki-Miyaura coupling.

N-Arylation: Expanding Structural Diversity

Functionalization of the nitrogen atom of the oxindole ring via N-arylation introduces another vector for modifying the molecule's properties.[10] Palladium-catalyzed Buchwald-Hartwig amination is a highly effective method for this transformation.[11]

Protocol 5.1: Buchwald-Hartwig N-Arylation

Rationale: This reaction involves the palladium-catalyzed coupling of an amine (in this case, the oxindole nitrogen) with an aryl halide or triflate.[11] The choice of a bulky, electron-rich phosphine ligand is critical for the efficiency of the catalytic cycle.[11] A strong, non-nucleophilic base is required to deprotonate the oxindole nitrogen.

Step-by-Step Protocol:

- Preparation: In a glovebox or under an inert atmosphere, combine **5-carboxyoxindole** (protected as an ester, 1 equivalent), the aryl halide (1.2 equivalents), a palladium precatalyst like Pd₂(dba)₃ (2.5 mol%), and a suitable ligand such as XPhos (5 mol%).
- Base Addition: Add a strong base, such as sodium tert-butoxide (NaOtBu) (1.4 equivalents). [\[11\]](#)
- Solvent: Add an anhydrous, deoxygenated solvent like toluene or dioxane.
- Reaction: Seal the reaction vessel and heat to 80-110 °C for 12-24 hours. Monitor the reaction by LC-MS.
- Workup: Cool the reaction to room temperature, dilute with an organic solvent, and wash with water and brine.
- Purification: Dry the organic layer, concentrate, and purify the crude product by flash column chromatography.
- Deprotection (if necessary): If the carboxylic acid was protected as an ester, it can be hydrolyzed back to the carboxylic acid using standard conditions (e.g., LiOH in THF/water). [\[12\]](#)

Reagent	Equivalents/Amount	Purpose
5-Carboxyester-oxindole	1.0	Starting material (protected)
Aryl Halide	1.2	Arylating agent
Pd ₂ (dba) ₃	2.5 mol%	Palladium precatalyst
XPhos	5 mol%	Ligand
NaOtBu	1.4	Strong, non-nucleophilic base
Toluene/Dioxane	-	Anhydrous, deoxygenated solvent

Conclusion and Future Directions

The protocols outlined in this application note provide a robust foundation for the functionalization of **5-carboxyoxindole**. The strategic application of amide coupling, esterification, Suzuki coupling, and N-arylation allows for the creation of diverse libraries of compounds for screening in drug discovery programs. Further exploration of other C-H functionalization techniques and the use of novel coupling partners will undoubtedly continue to expand the chemical space accessible from this versatile scaffold.[13]

References

- Synthesis and in vitro pharmacological evaluation of indolyl carboxylic amide analogues as D3 dopamine receptor selective ligands. PubMed Central. Available at: [\[Link\]](#)
- A new synthesis of indole 5-carboxylic acids and 6-hydroxy-indole-5-carboxylic acids in the preparation of an o-hydroxylated metabolite of vilazodone. PubMed. Available at: [\[Link\]](#)
- Recent Progress Concerning the N-Arylation of Indoles. PMC - NIH. Available at: [\[Link\]](#)
- 2-Oxindole and related heterocycles: synthetic methodologies for their natural products and related derivatives. PMC - PubMed Central. Available at: [\[Link\]](#)
- Fischer Esterification - Carboxylic Acid to Ester Under Acidic Conditions. Master Organic Chemistry. Available at: [\[Link\]](#)
- Catalyst-Controlled Directing Group Translocation in the Site Selective C–H Functionalization of 3-Carboxamide Indoles and Metallocarbenes. ChemRxiv. Available at: [\[Link\]](#)
- The Suzuki Reaction Applied to the Synthesis of Novel Pyrrolyl and Thiophenyl Indazoles. MDPI. Available at: [\[Link\]](#)
- N-Arylation by Nickel-Mediated Carbonyl Deletion from Carbox-amides Enabled by Visible Light. ChemRxiv. Available at: [\[Link\]](#)
- REGIOSPECIFIC FUNCTIONALIZATION OF INDOLE-2-CARBOXYLATES AND DIASTEREOSELECTIVE PREPARATION OF THE CORRESPONDING INDOLINES.

HETEROCYCLES. Available at: [\[Link\]](#)

- Decarboxylative Suzuki–Miyaura coupling of (hetero)aromatic carboxylic acids using iodine as the terminal oxidant. Chemical Communications (RSC Publishing). Available at: [\[Link\]](#)
- Optimized Amide Bond Reaction Using Heterocyclic Compounds and Carboxylic Acid. Technology Networks. Available at: [\[Link\]](#)
- esterification - alcohols and carboxylic acids. Chemguide. Available at: [\[Link\]](#)
- Simple Method for the Esterification of Carboxylic Acids. Organic Chemistry Portal. Available at: [\[Link\]](#)
- Stereoselective synthesis and applications of spirocyclic oxindoles. Organic Chemistry Frontiers (RSC Publishing). Available at: [\[Link\]](#)
- Process for preparation of 5-substituted indole derivatives. Google Patents.
- Process optimization for acid-amine coupling: a catalytic approach. Current Chemistry Letters. Available at: [\[Link\]](#)
- C-H Functionalization of indoles and oxindoles through CDC reactions. ScienceDirect. Available at: [\[Link\]](#)
- Amide formation from carboxylic acid derivatives. | Chemistry | Khan Academy. YouTube. Available at: [\[Link\]](#)
- Decarboxylative Synthesis of Functionalized Oxindoles via An Iron-Initiated Radical Chain Process and Application in Constructing Diverse Fused-Indoline Heterocycles. Wiley Online Library. Available at: [\[Link\]](#)
- Synthesis of Indole Oligomers Via Iterative Suzuki Couplings. ACS Publications. Available at: [\[Link\]](#)
- Directed C–H Functionalization of C3-Aldehyde, Ketone, and Acid/Ester-Substituted Free (NH) Indoles with Iodoarenes via a Palladium Catalyst System. PMC - NIH. Available at: [\[Link\]](#)

- Efficient Palladium-Catalyzed N-Arylation of Indoles. Organic Chemistry Portal. Available at: [\[Link\]](#)
- Oxindole derivatives with pharmaceutical applications. ResearchGate. Available at: [\[Link\]](#)
- Facile Synthesis of 5-Aryl-N-(pyrazin-2-yl)thiophene-2-carboxamides via Suzuki Cross-Coupling Reactions, Their Electronic and Nonlinear Optical Properties through DFT Calculations. MDPI. Available at: [\[Link\]](#)
- How to Make Esters through Esterification | Examples Explained!. YouTube. Available at: [\[Link\]](#)
- 5-Aminooxazole as an internal traceless activator of C-terminal carboxylic acid: rapid access to diversely functionalized cyclodepsipeptides. PubMed. Available at: [\[Link\]](#)
- Amide coupling reaction in medicinal chemistry. Coupling reagents. HepatoChem. Available at: [\[Link\]](#)
- Discovery of a New Polymorph of 5-Methoxy-1H-Indole-2-Carboxylic Acid: Characterization by X-ray Diffraction, Infrared Spectroscopy, and DFT Calculations. MDPI. Available at: [\[Link\]](#)
- Synthesis of 5-hydroxy- and 5-O-benzyl-1H-indole-2-carboxylic acids 10... ResearchGate. Available at: [\[Link\]](#)
- Visible Light Mediated Synthesis of Oxindoles | Request PDF. ResearchGate. Available at: [\[Link\]](#)
- Scope of N-arylation of 5-nitroindole with different iodobenzenes. Reaction conditions. ResearchGate. Available at: [\[Link\]](#)
- Decarbonylative Pd-Catalyzed Suzuki Cross-Coupling for the Synthesis of Structurally Diverse Heterobiaryls. PMC - NIH. Available at: [\[Link\]](#)
- Straightforward synthesis of N-arylindoles via one-pot Fischer indolisation–indole N-arylation. PMC - NIH. Available at: [\[Link\]](#)

Need Custom Synthesis?

BenchChem offers custom synthesis for rare earth carbides and specific isotopic labeling.

Email: info@benchchem.com or [Request Quote Online](#).

Sources

- 1. 2-Oxindole and related heterocycles: synthetic methodologies for their natural products and related derivatives - PMC [[pmc.ncbi.nlm.nih.gov](https://pubmed.ncbi.nlm.nih.gov/)]
- 2. [researchgate.net](https://www.researchgate.net/) [[researchgate.net](https://www.researchgate.net/)]
- 3. Straightforward synthesis of N-arylindoles via one-pot Fischer indolisation–indole N-arylation - PMC [[pmc.ncbi.nlm.nih.gov](https://pubmed.ncbi.nlm.nih.gov/)]
- 4. [growingscience.com](https://www.growingscience.com/) [[growingscience.com](https://www.growingscience.com/)]
- 5. [masterorganicchemistry.com](https://www.masterorganicchemistry.com/) [[masterorganicchemistry.com](https://www.masterorganicchemistry.com/)]
- 6. [chemguide.co.uk](https://www.chemguide.co.uk/) [[chemguide.co.uk](https://www.chemguide.co.uk/)]
- 7. The Suzuki Reaction Applied to the Synthesis of Novel Pyrrolyl and Thiophenyl Indazoles - PMC [[pmc.ncbi.nlm.nih.gov](https://pubmed.ncbi.nlm.nih.gov/)]
- 8. Decarboxylative Suzuki–Miyaura coupling of (hetero)aromatic carboxylic acids using iodine as the terminal oxidant - Chemical Communications (RSC Publishing) [pubs.rsc.org]
- 9. Decarbonylative Pd-Catalyzed Suzuki Cross-Coupling for the Synthesis of Structurally Diverse Heterobiaryls - PMC [[pmc.ncbi.nlm.nih.gov](https://pubmed.ncbi.nlm.nih.gov/)]
- 10. Recent Progress Concerning the N-Arylation of Indoles - PMC [[pmc.ncbi.nlm.nih.gov](https://pubmed.ncbi.nlm.nih.gov/)]
- 11. Efficient Palladium-Catalyzed N-Arylation of Indoles [[organic-chemistry.org](https://www.organic-chemistry.org/)]
- 12. triggered.stanford.clockss.org [triggered.stanford.clockss.org]
- 13. chemrxiv.org [chemrxiv.org]
- To cite this document: BenchChem. [Application Notes and Protocols for the Functionalization of 5-Carboxyoxindole]. BenchChem, [2026]. [Online PDF]. Available at: [<https://www.benchchem.com/product/b009593/docs#application-notes-and-protocols-for-the-functionalization-of-5-carboxyoxindole>]

Disclaimer & Data Validity:

The information provided in this document is for Research Use Only (RUO) and is strictly not intended for diagnostic or therapeutic procedures. While BenchChem strives to provide accurate protocols, we make no warranties, express or implied, regarding the fitness of this product for every specific experimental setup.

Technical Support: The protocols provided are for reference purposes. Unsure if this reagent suits your experiment?

Need Industrial/Bulk Grade? [Request Custom Synthesis Quote](#)

BenchChem

Our mission is to be the trusted global source of essential and advanced chemicals, empowering scientists and researchers to drive progress in science and industry.

Contact

Address: 3281 E Guasti Rd
Ontario, CA 91761, United States
Phone: (601) 213-4426
Email: info@benchchem.com

[Contact our Ph.D. Support Team for a compatibility check](#)