

# Spectroscopic Characterization of n-Propylsulfamoyl Chloride: A Technical Guide

**Author:** BenchChem Technical Support Team. **Date:** January 2026

## Compound of Interest

Compound Name: *n*-Propylsulfamoyl chloride

Cat. No.: B089278

[Get Quote](#)

This technical guide provides an in-depth analysis of the spectroscopic profile of **n-Propylsulfamoyl chloride** (C<sub>3</sub>H<sub>8</sub>ClNO<sub>2</sub>S), a key intermediate in synthetic chemistry. Designed for researchers, scientists, and professionals in drug development, this document synthesizes expected spectroscopic data with practical, field-proven insights into their acquisition and interpretation. While direct experimental spectra for this specific compound are not widely published, this guide extrapolates from established principles and data for analogous sulfonyl chlorides to provide a robust predictive framework.

## Introduction to n-Propylsulfamoyl Chloride and its Spectroscopic Analysis

**n-Propylsulfamoyl chloride** is a reactive chemical intermediate used in the synthesis of a variety of organic compounds, including sulfonamides, which are of significant interest in medicinal chemistry. The precise characterization of this compound is critical to ensure the purity and identity of downstream products. Spectroscopic methods such as Nuclear Magnetic Resonance (NMR), Infrared (IR) Spectroscopy, and Mass Spectrometry (MS) are indispensable tools for this purpose. This guide will delve into the expected spectroscopic signatures of **n-Propylsulfamoyl chloride** and the underlying principles of their interpretation.

## Nuclear Magnetic Resonance (NMR) Spectroscopy

NMR spectroscopy is arguably the most powerful tool for the structural elucidation of organic molecules, providing detailed information about the chemical environment of hydrogen (<sup>1</sup>H

NMR) and carbon ( $^{13}\text{C}$  NMR) atoms.

## Expected $^1\text{H}$ NMR Spectral Data

The  $^1\text{H}$  NMR spectrum of **n-Propylsulfamoyl chloride** is anticipated to show three distinct signals corresponding to the three non-equivalent sets of protons in the n-propyl chain. The protons on the carbon atom alpha to the electron-withdrawing sulfamoyl chloride group will be the most deshielded.

Proton Assignment	Expected Chemical Shift ( $\delta$ ) / ppm	Multiplicity	Coupling Constant (J) / Hz
-CH <sub>2</sub> - (alpha)	~3.4 - 3.6	Triplet	~7.0
-CH <sub>2</sub> - (beta)	~1.7 - 1.9	Sextet	~7.0
-CH <sub>3</sub> (gamma)	~0.9 - 1.1	Triplet	~7.0

Interpretation of the  $^1\text{H}$  NMR Spectrum:

The downfield chemical shift of the alpha methylene protons (~3.4 - 3.6 ppm) is a direct consequence of the strong electron-withdrawing nature of the adjacent sulfonyl chloride group. [1] The beta methylene protons are expected to appear as a sextet due to coupling with both the alpha and gamma protons. The terminal methyl protons will be the most shielded, appearing as an upfield triplet.

## Expected $^{13}\text{C}$ NMR Spectral Data

The  $^{13}\text{C}$  NMR spectrum will provide complementary information, showing three signals for the three carbon atoms of the n-propyl group.

Carbon Assignment	Expected Chemical Shift ( $\delta$ ) / ppm
-CH <sub>2</sub> - (alpha)	~50 - 55
-CH <sub>2</sub> - (beta)	~22 - 26
-CH <sub>3</sub> (gamma)	~10 - 13

Interpretation of the  $^{13}\text{C}$  NMR Spectrum:

Similar to the  $^1\text{H}$  NMR spectrum, the carbon atom directly attached to the sulfamoyl chloride group (alpha carbon) is significantly deshielded. The chemical shifts of the beta and gamma carbons are in the typical aliphatic region.

## Experimental Protocol for NMR Data Acquisition

A standard protocol for acquiring high-quality NMR spectra of **n-Propylsulfamoyl chloride** is as follows:

- **Sample Preparation:** Accurately weigh approximately 10-20 mg of **n-Propylsulfamoyl chloride** into a clean, dry NMR tube. Add approximately 0.6 mL of a suitable deuterated solvent (e.g.,  $\text{CDCl}_3$ ). Note: Due to the moisture sensitivity of sulfonyl chlorides, ensure all glassware is scrupulously dried and use a dry solvent.
- **Instrument Parameters (for a 400 MHz spectrometer):**
  - $^1\text{H}$  NMR:
    - **Pulse Program:** Standard single-pulse experiment (e.g., 'zg30').
    - **Acquisition Time:** ~3-4 seconds.
    - **Relaxation Delay:** 1-2 seconds.
    - **Number of Scans:** 16-32.
  - $^{13}\text{C}$  NMR:
    - **Pulse Program:** Proton-decoupled pulse program (e.g., 'zgpg30').
    - **Acquisition Time:** ~1-2 seconds.
    - **Relaxation Delay:** 2-5 seconds.
    - **Number of Scans:** 1024 or more, depending on sample concentration.

- Data Processing: Apply Fourier transformation, phase correction, and baseline correction to the acquired Free Induction Decay (FID) to obtain the final spectrum.

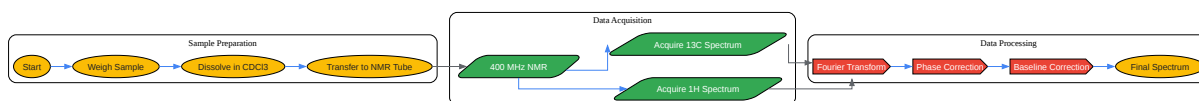

[Click to download full resolution via product page](#)

Caption: Workflow for NMR data acquisition and processing.

## Infrared (IR) Spectroscopy

IR spectroscopy is a rapid and effective technique for identifying functional groups within a molecule. For **n-Propylsulfamoyl chloride**, the key vibrational modes are associated with the sulfonyl chloride group.

## Expected IR Spectral Data

The IR spectrum will be dominated by strong absorptions from the S=O bonds.

Vibrational Mode	**Expected Frequency (cm <sup>-1</sup> ) **	Intensity
Asymmetric S=O Stretch	1375 - 1410	Strong
Symmetric S=O Stretch	1185 - 1204	Strong
S-Cl Stretch	375 - 385	Strong
C-H Stretch (aliphatic)	2800 - 3000	Medium-Strong

Interpretation of the IR Spectrum:

The presence of two very strong absorption bands in the ranges of 1375-1410  $\text{cm}^{-1}$  and 1185-1204  $\text{cm}^{-1}$  is highly characteristic of the sulfonyl chloride functional group.[2][3] The band corresponding to the S-Cl stretch is expected at a lower frequency.[4] The C-H stretching vibrations of the n-propyl group will also be prominent.

## Experimental Protocol for IR Data Acquisition

A typical procedure for obtaining an IR spectrum of liquid **n-Propylsulfamoyl chloride** is as follows:

- **Sample Preparation:** A neat liquid sample can be analyzed by placing a drop between two salt plates (e.g., NaCl or KBr). Alternatively, Attenuated Total Reflectance (ATR) can be used, which requires placing a small drop of the sample directly onto the ATR crystal.
- **Instrument Parameters (FTIR Spectrometer):**
  - Spectral Range: 4000 - 400  $\text{cm}^{-1}$ .
  - Resolution: 4  $\text{cm}^{-1}$ .
  - Number of Scans: 16-32.
- **Data Acquisition:** A background spectrum of the empty sample compartment or clean ATR crystal is collected first. The sample spectrum is then acquired and ratioed against the background to produce the final absorbance or transmittance spectrum.

## Mass Spectrometry (MS)

Mass spectrometry provides information about the molecular weight and fragmentation pattern of a compound, which is invaluable for confirming its identity.

## Expected Mass Spectral Data

The mass spectrum of **n-Propylsulfamoyl chloride** is expected to show a molecular ion peak and several characteristic fragment ions.

m/z	Assignment	Notes
157/159	[M] <sup>+</sup>	Molecular ion peak, showing the characteristic 3:1 isotopic pattern for chlorine.
122	[M - Cl] <sup>+</sup>	Loss of a chlorine radical.
99/101	[SO <sub>2</sub> Cl] <sup>+</sup>	Sulfonyl chloride fragment.
57	[C <sub>4</sub> H <sub>9</sub> ] <sup>+</sup>	Propyl cation fragment.

Interpretation of the Mass Spectrum:

A key feature in the mass spectrum of a sulfonyl chloride is the isotopic pattern of chlorine.<sup>[2]</sup> The natural abundance of <sup>35</sup>Cl and <sup>37</sup>Cl is approximately 3:1, so the molecular ion will appear as two peaks (M<sup>+</sup> and M+2) with this intensity ratio. Common fragmentation pathways include the loss of a chlorine atom and cleavage of the C-S bond.

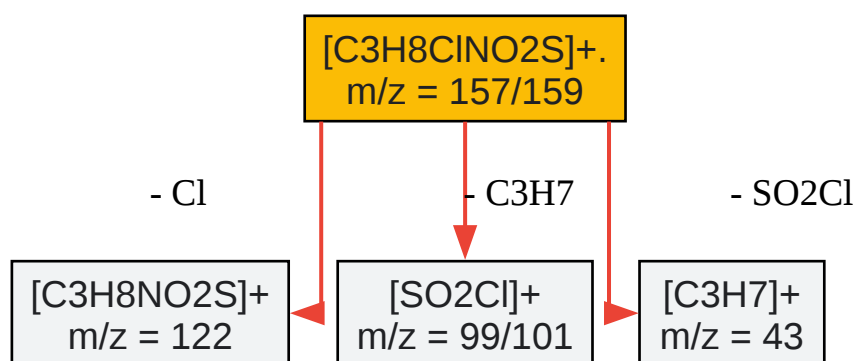

[Click to download full resolution via product page](#)

Caption: Expected fragmentation of **n-Propylsulfamoyl chloride**.

## Experimental Protocol for MS Data Acquisition

A general procedure for analyzing **n-Propylsulfamoyl chloride** by mass spectrometry is as follows:

- **Sample Introduction:** The sample can be introduced into the mass spectrometer via direct infusion or, more commonly, through a gas chromatograph (GC-MS).

- Ionization: Electron Impact (EI) is a common ionization technique for this type of molecule.
- Instrument Parameters (GC-MS):
  - GC: Use a suitable capillary column (e.g., RTX-5MS). The oven temperature program should be optimized to ensure good separation.
  - MS:
    - Ion Source Temperature: ~200-250 °C.
    - Mass Range: m/z 40-200.
    - Acquisition Mode: Scan.

## Conclusion

The spectroscopic characterization of **n-Propylsulfamoyl chloride** relies on a combination of NMR, IR, and MS techniques. While experimental data for this specific compound is not readily available in public databases, a comprehensive understanding of its expected spectroscopic features can be derived from the analysis of related compounds and the fundamental principles of spectroscopy. This guide provides a robust framework for the identification and characterization of **n-Propylsulfamoyl chloride**, empowering researchers to proceed with confidence in their synthetic endeavors.

## References

- Moser, A. (2008). IR, NMR and MS of a Sulfonyl Chloride compound. ACD/Labs. Available at: [\[Link\]](#)
- Sulfonyl chloride infrared spectra. Chemistry. Available at: [\[Link\]](#)
- King, J. F., & Durst, T. (1963). THE SULFUR-CHLORINE STRETCHING BAND IN SULFONYL CHLORIDES. Canadian Journal of Chemistry, 41(8), 1983-1985. Available at: [\[Link\]](#)

### Need Custom Synthesis?

BenchChem offers custom synthesis for rare earth carbides and specific isotopic labeling.

Email: [info@benchchem.com](mailto:info@benchchem.com) or [Request Quote Online](#).

## Sources

- 1. [acdlabs.com](https://acdlabs.com) [[acdlabs.com](https://acdlabs.com)]
- 2. [pdf.benchchem.com](https://pdf.benchchem.com) [[pdf.benchchem.com](https://pdf.benchchem.com)]
- 3. Chemistry: Sufonyl chloride infrared spectra [[openchemistryhelp.blogspot.com](https://openchemistryhelp.blogspot.com)]
- 4. [cdnsiencepub.com](https://cdnsiencepub.com) [[cdnsiencepub.com](https://cdnsiencepub.com)]
- To cite this document: BenchChem. [Spectroscopic Characterization of n-Propylsulfamoyl Chloride: A Technical Guide]. BenchChem, [2026]. [Online PDF]. Available at: [<https://www.benchchem.com/product/b089278#n-propylsulfamoyl-chloride-spectroscopic-data-nmr-ir-ms>]

---

### Disclaimer & Data Validity:

The information provided in this document is for Research Use Only (RUO) and is strictly not intended for diagnostic or therapeutic procedures. While BenchChem strives to provide accurate protocols, we make no warranties, express or implied, regarding the fitness of this product for every specific experimental setup.

**Technical Support:** The protocols provided are for reference purposes. Unsure if this reagent suits your experiment? [[Contact our Ph.D. Support Team for a compatibility check](#)]

**Need Industrial/Bulk Grade?** [Request Custom Synthesis Quote](#)

# BenchChem

Our mission is to be the trusted global source of essential and advanced chemicals, empowering scientists and researchers to drive progress in science and industry.

## Contact

Address: 3281 E Guasti Rd

Ontario, CA 91761, United States

Phone: (601) 213-4426

Email: [info@benchchem.com](mailto:info@benchchem.com)