

# An In-Depth Technical Guide to Butyl Zirconate for Advanced Research Applications

**Author:** BenchChem Technical Support Team. **Date:** May 2026

## Compound of Interest

Compound Name: *Butyl zirconate*

CAS No.: *1071-76-7*

Cat. No.: *B089527*

[Get Quote](#)

## Introduction

Zirconium(IV) butoxide, commonly known as **butyl zirconate**, is a highly versatile organometallic compound at the nexus of catalysis, materials science, and advanced chemical synthesis. As a zirconium alkoxide, its reactivity is dominated by the electron-deficient zirconium center and its four butoxide ligands. This unique electronic and steric environment makes it an indispensable tool for researchers. While often supplied as a solution in 1-butanol, its true potential is realized in its role as a potent Lewis acid catalyst and as a high-purity precursor for the sol-gel synthesis of zirconium-based materials.<sup>[1]</sup> This guide provides an in-depth exploration of **butyl zirconate**, from its fundamental properties to its application in sophisticated experimental workflows, with a focus on the causality behind its utility for researchers, scientists, and drug development professionals.

## Chemical Identity and Physicochemical Properties

A precise understanding of a reagent's properties is the foundation of reproducible science. **Butyl zirconate** is most commonly available as the n-butyl isomer, though other isomers like tert-**butyl zirconate** exist and offer different reactivity profiles due to steric hindrance.

## Nomenclature and Identification

Identifier	Value
Primary Name	Zirconium(IV) n-butoxide
Synonyms	n-Butyl zirconate, Tetrabutyl zirconate, Zirconic acid butyl ester
CAS Number	1071-76-7
Molecular Formula	C <sub>16</sub> H <sub>36</sub> O <sub>4</sub> Zr
SMILES String	CCCCO(OCCCC)OCCCC
InChI Key	BSDOQSMQCZQLDV-UHFFFAOYSA-N

## Core Physicochemical Data

The properties below dictate the handling, reaction conditions, and application scope of **n-butyl zirconate**. Its high moisture sensitivity, for instance, is a direct consequence of the susceptibility of the Zr-O bond to hydrolysis.

Property	Value	Source
Molecular Weight	383.68 g/mol	[2]
Appearance	Clear yellow, viscous liquid	[3]
Density	~1.049 g/mL at 25 °C	
Boiling Point	~117 °C (for 80% solution in 1-butanol)	
Flash Point	38 °C (100.4 °F) - closed cup	
Solubility	Soluble in most organic solvents; hydrolyzes readily in water.[4]	
Refractive Index	n <sub>20/D</sub> ~1.466	

# Synthesis, Handling, and Causality of Reactivity

## Synthesis Overview

The synthesis of zirconium alkoxides like **butyl zirconate** is typically achieved through reactions that are rigorously free of water to prevent premature hydrolysis and oligomerization. A common and effective laboratory-scale approach involves the alcoholysis of a suitable zirconium precursor, such as tetrakis(diethylamido)zirconium(IV), with the corresponding alcohol (in this case, 1-butanol).

The choice of an amido precursor is strategic; the reaction with alcohol liberates volatile diethylamine, which can be easily removed, driving the reaction to completion and yielding a high-purity product.[2]

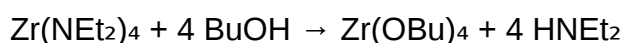

This method avoids halide impurities that can be problematic in syntheses starting from zirconium tetrachloride ( $\text{ZrCl}_4$ ).[5]

## Mandatory Handling and Storage Protocols

The utility of **butyl zirconate** is directly linked to its reactivity, which also necessitates stringent handling procedures.

- **Inert Atmosphere:** **Butyl zirconate** is extremely sensitive to moisture.[6] The zirconium center is a hard Lewis acid, making it highly electrophilic and prone to attack by nucleophiles like water. This initiates a rapid, often uncontrollable hydrolysis and condensation cascade. Consequently, all handling, transfers, and reactions must be performed under a dry, inert atmosphere (e.g., nitrogen or argon) using Schlenk line or glovebox techniques.
- **Anhydrous Solvents:** All solvents and reagents used with **butyl zirconate** must be rigorously dried. The presence of even trace amounts of water can lead to the formation of zirconium-oxo clusters, altering the reagent's solubility, reactivity, and the morphology of any resulting materials.[7]
- **Storage:** The material should be stored in a tightly sealed container under an inert atmosphere, typically in a cool, dry place away from heat and sources of ignition, given its flammability.

## Mechanism of Action: The Chemical Logic

The functionality of **butyl zirconate** stems from two primary reaction pathways: its action as a Lewis acid and its role as a molecular precursor to inorganic oxides via hydrolysis and condensation.

### Lewis Acid Catalysis

The zirconium(IV) center possesses vacant d-orbitals, rendering it a potent Lewis acid capable of coordinating to electron-rich sites, such as the carbonyl oxygen of an ester or carboxylic acid. This coordination polarizes the C=O bond, increasing the electrophilicity of the carbonyl carbon and making it significantly more susceptible to nucleophilic attack. This mechanism is central to its use in esterification and transesterification reactions, where it offers advantages over traditional Brønsted acids, including higher yields and lower catalyst loading under milder conditions.[1][6]

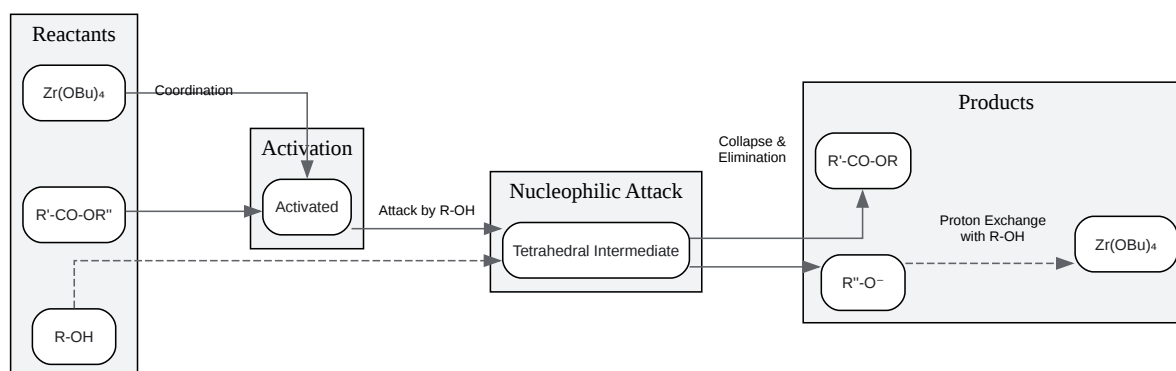

[Click to download full resolution via product page](#)

Caption: Lewis acid catalysis of transesterification by **butyl zirconate**.

### Hydrolysis and Condensation Pathway

When **butyl zirconate** is intentionally exposed to water in a controlled manner (as in sol-gel synthesis), a two-step process occurs. First, hydrolysis replaces butoxide ligands with hydroxyl groups. Second, condensation eliminates water or butanol to form Zr-O-Zr bridges. This process continues, building up a three-dimensional zirconium-oxo network, which is the "sol." Further processing removes the solvent to yield a solid "gel," which can be calcined to form pure, crystalline zirconia ( $\text{ZrO}_2$ ).<sup>[8][9]</sup> The rate of these reactions and the final structure of the material are highly dependent on parameters like the water-to-alkoxide ratio, pH, and temperature.<sup>[10]</sup>

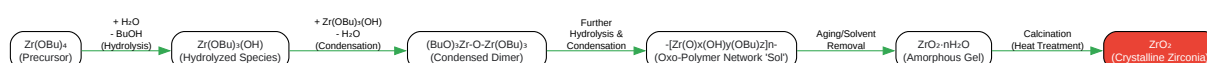

[Click to download full resolution via product page](#)

Caption: Sol-gel pathway from **butyl zirconate** to crystalline zirconia.

## Applications in Research and Drug Development Catalysis in Complex Organic Synthesis

Beyond simple esterifications, zirconium-based catalysts are valuable in constructing complex molecular architectures relevant to drug discovery. Their low toxicity compared to many other transition metals makes them an attractive option. They have been employed to catalyze a range of organic transformations, including reductions, rearrangements, and cycloadditions.<sup>[11]</sup> The ability to function under mild conditions helps preserve sensitive functional groups often present in pharmaceutical intermediates.

## Precursor for Advanced Materials (Sol-Gel Processing)

The sol-gel process using **butyl zirconate** is a cornerstone of advanced materials synthesis, enabling the creation of high-purity zirconia with tailored properties.<sup>[4]</sup> Zirconia's excellent biocompatibility, chemical inertness, and mechanical strength make it a prime candidate for biomedical applications.<sup>[11][12]</sup>

Experimental Protocol: Synthesis of Nanocrystalline Zirconia Powder

This protocol describes a typical lab-scale sol-gel synthesis. The causality for each step is explained to ensure a self-validating workflow.

- Preparation (Justification: Inertness): Under an argon atmosphere, prepare a 0.1 M solution of Zirconium(IV) butoxide (ca. 80% in 1-butanol) in anhydrous ethanol. Rationale: Anhydrous conditions prevent premature, uncontrolled hydrolysis.
- Hydrolysis (Justification: Controlled Reaction): In a separate flask, prepare a solution of deionized water in ethanol. The molar ratio of water to the zirconium alkoxide (commonly denoted as R) is a critical parameter. For nanoparticles, an R value between 4 and 10 is often used. Slowly add the water/ethanol solution dropwise to the vigorously stirring zirconium butoxide solution at room temperature. Rationale: Slow, dropwise addition with vigorous stirring ensures homogeneous mixing and prevents localized, rapid precipitation, leading to more uniform particle sizes.[\[13\]](#)
- Aging (Justification: Network Formation): A white precipitate (the "sol") will form immediately. Allow the mixture to stir for 24 hours at room temperature. This "aging" step allows the hydrolysis and condensation reactions to proceed to completion, strengthening the gel network.
- Washing (Justification: Purity): Isolate the precipitate by centrifugation. Wash the resulting gel multiple times with ethanol to remove unreacted precursors and byproducts, then with water to remove residual organics.
- Drying (Justification: Gel Formation): Dry the washed gel in an oven at 80-100 °C for 12 hours to remove the solvent and form a xerogel.
- Calcination (Justification: Crystallization): Transfer the dried xerogel to a furnace. Heat the powder in air at a controlled rate (e.g., 5 °C/min) to a final temperature between 500-700 °C and hold for 2-4 hours. This step burns off any remaining organic residues and induces crystallization of the amorphous gel into the desired zirconia phase (e.g., tetragonal or monoclinic).[\[14\]](#)

## Biocompatible Coatings and Surface Modification

The ability to form thin, uniform, high-purity zirconia films makes **butyl zirconate** an excellent precursor for modifying the surfaces of biomedical implants (e.g., titanium or stainless steel).

[15] A zirconia coating can enhance biocompatibility, improve corrosion resistance, and provide a chemically inert barrier.[16][17] Such coatings can be applied via dip-coating or spin-coating a substrate with a prepared sol, followed by a controlled heat treatment to form a dense ceramic layer. These surfaces can then serve as platforms for further functionalization to improve osseointegration.[12][18]

## Safety and Disposal

**Butyl zirconate** is a hazardous chemical that requires careful handling.

- Hazards: It is a flammable liquid and vapor. It causes skin irritation and serious eye damage. It may also cause respiratory irritation and drowsiness or dizziness.[19]
- Precautions: Work in a well-ventilated fume hood. Wear appropriate personal protective equipment (PPE), including safety goggles, a face shield, flame-retardant lab coat, and chemical-resistant gloves. Keep away from heat, sparks, and open flames.
- Disposal: Dispose of waste material in accordance with local, regional, and national regulations. Due to its reactivity with water, it should not be disposed of down the drain. It is typically handled as a flammable organic waste.

## References

- 安徽维诚新材料科技有限公司. **Butyl zirconate**.
- Haz-Map. Zirconium(IV) butoxide - Hazardous Agents.
- ChemBK. (2024). N-**BUTYL ZIRCONATE**.
- De Roo, J., et al. (2023). Synthesis of zirconium(IV) and hafnium(IV) isopropoxide, sec-butoxide and tert-butoxide. Dalton Transactions. Retrieved from [\[Link\]](#)
- De Roo, J., et al. (2023). Synthesis of Zirconium(IV) and Hafnium(IV) isopropoxide and tert-butoxide. ChemRxiv. Retrieved from [\[Link\]](#)
- De Roo, J., et al. (2023). Synthesis of zirconium(IV) and hafnium(IV) isopropoxide, sec-butoxide and tert-butoxide. ChemRxiv. Retrieved from [\[Link\]](#)
- El-Katori, E. E., et al. (2020). Successive hydrolysis and condensation reactions of zirconium but-oxide Zr(BuO)<sub>4</sub> precursor. ResearchGate. Retrieved from [\[Link\]](#)

- Zielke, J. T. (1997). An investigation into the hydrolysis and condensation reactions of zirconium (IV) butoxides. TRACE: Tennessee Research and Creative Exchange. Retrieved from [\[Link\]](#)
- Parac-Vogt, T. N., et al. (2024). The Central Role of Oxo Clusters in Zirconium-Based Esterification Catalysis. Small Science. Retrieved from [\[Link\]](#)
- Semantic Scholar. (2003). Sol-Gel Synthesis and Phase Evolution Behavior of Sterically Stabilized Nanocrystalline Zirconia. Retrieved from [\[Link\]](#)
- Zielke, J. T. (1997). An investigation into the hydrolysis and condensation reactions of zir. TRACE: Tennessee Research and Creative Exchange. Retrieved from [\[Link\]](#)
- ResearchGate. (2021). Sol-Gel Production of Zirconia Nanoparticles with a New Organic Precursor. Retrieved from [\[Link\]](#)
- ResearchGate. (2018). Synthesis of zirconia nanoparticles by sol-gel. Influence of acidity-basicity on the stability transformation, particle, and crystallite size. Retrieved from [\[Link\]](#)
- ResearchGate. (2017). Synthesis of Zirconium Oxide Nanoparticle by Sol-Gel Technique. Retrieved from [\[Link\]](#)
- Scientific Reports. (2019). Bioactive coating of zirconia toughened alumina ceramic implants improves cancellous osseointegration. PubMed. Retrieved from [\[Link\]](#)
- ResearchGate. (2020). Coatings on zirconia for medical applications. Retrieved from [\[Link\]](#)
- The Journal of Organic Chemistry. (2020). Kinetic Analysis as an Optimization Tool for Catalytic Esterification with a Moisture-Tolerant Zirconium Complex. ACS Publications. Retrieved from [\[Link\]](#)
- Frontiers in Bioengineering and Biotechnology. (2021). Zirconia Based Dental Biomaterials: Structure, Mechanical Properties, Biocompatibility, Surface Modification, and Applications as Implant. Retrieved from [\[Link\]](#)
- NINGBO INNO PHARMCHEM CO.,LTD. Zirconium(IV) tert-butoxide: A High-Purity Precursor for Advanced Materials Manufacturing. Retrieved from [\[Link\]](#)

- OAText. (2017). Surface coatings of titanium and zirconia. Retrieved from [[Link](#)]
- Journal of Medical Device Technology. (2023). Protective Coatings for Zirconium-Based Alloys: Improving their Mechanical and Biological Properties by YSZ Coating. Retrieved from [[Link](#)]
- ElectronicsAndBooks. Zirconium Alkoxides in Catalysis. Retrieved from [[Link](#)]
- ResearchGate. (2002). Investigation of the complex structure and the hydrolysis process in butanol solutions of zirconium butoxide. Retrieved from [[Link](#)]
- Inorganic Chemistry. (2022). Synthesis of Heterometallic Zirconium Alkoxide Single-Source Precursors for Bimetallic Oxide Deposition. PMC - PubMed Central. Retrieved from [[Link](#)]

#### *Need Custom Synthesis?*

*BenchChem offers custom synthesis for rare earth carbides and specific isotopic labeling.*

*Email: [info@benchchem.com](mailto:info@benchchem.com) or [Request Quote Online](#).*

## Sources

- [1. The Central Role of Oxo Clusters in Zirconium-Based Esterification Catalysis - PMC \[pmc.ncbi.nlm.nih.gov\]](#)
- [2. Synthesis of zirconium\(iv\) and hafnium\(iv\) isopropoxide, sec-butoxide and tert-butoxide - PMC \[pmc.ncbi.nlm.nih.gov\]](#)
- [3. researchgate.net \[researchgate.net\]](#)
- [4. malayajournal.org \[malayajournal.org\]](#)
- [5. chemrxiv.org \[chemrxiv.org\]](#)
- [6. Synthesis of zirconium\(iv\) and hafnium\(iv\) isopropoxide, sec-butoxide and tert-butoxide - Dalton Transactions \(RSC Publishing\) \[pubs.rsc.org\]](#)
- [7. trace.tennessee.edu \[trace.tennessee.edu\]](#)
- [8. researchgate.net \[researchgate.net\]](#)
- [9. "An investigation into the hydrolysis and condensation reactions of zir" by Jason Tylor Zielke \[trace.tennessee.edu\]](#)

- [10. researchgate.net \[researchgate.net\]](#)
- [11. frontiersin.org \[frontiersin.org\]](#)
- [12. oatext.com \[oatext.com\]](#)
- [13. Sol-Gel Synthesis and Phase Evolution Behavior of Sterically Stabilized Nanocrystalline Zirconia | Semantic Scholar \[semanticscholar.org\]](#)
- [14. researchgate.net \[researchgate.net\]](#)
- [15. Synthesis of Heterometallic Zirconium Alkoxide Single-Source Precursors for Bimetallic Oxide Deposition - PMC \[pmc.ncbi.nlm.nih.gov\]](#)
- [16. researchgate.net \[researchgate.net\]](#)
- [17. Protective Coatings for Zirconium-Based Alloys: Improving their Mechanical and Biological Properties by YSZ Coating | Journal of Medical Device Technology \[jmeditec.utm.my\]](#)
- [18. Bioactive coating of zirconia toughened alumina ceramic implants improves cancellous osseointegration - PubMed \[pubmed.ncbi.nlm.nih.gov\]](#)
- [19. researchgate.net \[researchgate.net\]](#)
- [To cite this document: BenchChem. \[An In-Depth Technical Guide to Butyl Zirconate for Advanced Research Applications\]. BenchChem, \[2026\]. \[Online PDF\]. Available at: \[https://www.benchchem.com/product/b089527/docs#an-in-depth-technical-guide-to-butyl-zirconate-for-advanced-research-applications\]](#)

---

### Disclaimer & Data Validity:

The information provided in this document is for Research Use Only (RUO) and is strictly not intended for diagnostic or therapeutic procedures. While BenchChem strives to provide accurate protocols, we make no warranties, express or implied, regarding the fitness of this product for every specific experimental setup.

**Technical Support:** The protocols provided are for reference purposes. Unsure if this reagent suits your experiment?

**Need Industrial/Bulk Grade?** [Request Custom Synthesis Quote](#)

# BenchChem

Our mission is to be the trusted global source of essential and advanced chemicals, empowering scientists and researchers to drive progress in science and industry.

## Contact

Address: 3281 E Guasti Rd

Ontario, CA 91761, United States

Phone: (601) 213-4426

Email: [info@benchchem.com](mailto:info@benchchem.com)

[Contact our Ph.D. Support Team for a compatibility check](#)