

A Technical Guide to β -Ionone: Biosynthesis, Function, and Analysis in Flora

Author: BenchChem Technical Support Team. **Date:** April 2026

Compound of Interest

Compound Name: *beta-Ionone*

CAS No.: 14901-07-6

Cat. No.: B089335

[Get Quote](#)

Abstract

β -ionone is a C13-norisoprenoid, a volatile organic compound (VOC) derived from the enzymatic degradation of carotenoids.[1][2] It is a significant contributor to the characteristic aroma of many fruits and flowers, including roses, violets, raspberries, and tomatoes.[2][3][4] Possessing a distinctive floral, woody, and slightly fruity scent, β -ionone's influence on sensory perception belies its often low concentrations, a testament to its extremely low odor threshold of 0.007 ppb in air.[1][5] Beyond its role as an aroma compound, β -ionone serves critical ecological functions for plants, acting as an attractant for pollinators or as a defense compound against herbivores and pathogens.[1][6] This guide provides an in-depth examination of β -ionone, covering its biosynthetic pathway, its multifaceted biological roles, and the analytical methodologies essential for its extraction and quantification. It is intended for researchers in plant science, analytical chemistry, and drug development seeking a comprehensive understanding of this pivotal VOC.

The Chemistry and Occurrence of β -Ionone

β -ionone (4-(2,6,6-trimethyl-1-cyclohexen-1-yl)-3-buten-2-one) is a cyclic ketone with the chemical formula $C_{13}H_{20}O$.^[7] It exists as a pale yellow liquid at room temperature and is largely insoluble in water but soluble in oils and alcohols.^[7] This lipophilic nature is critical to its function as a volatile compound that can traverse cellular membranes and be released into the atmosphere.

Its presence is widespread throughout the plant kingdom, contributing significantly to the flavor and fragrance profiles of numerous species. The concentration and importance of β -ionone can vary dramatically between different plants and even different tissues within the same plant.^[1]
^[4]



FULL PROTOCOL TRUNCATED

To view exact molar ratios, purification steps, and HRP optimization data, please view the interactive version.

[Unlock Full Protocol on Website](#)

Biosynthesis: The Cleavage of Carotenoids

The primary route to β -ionone formation in plants is the oxidative cleavage of β -carotene.^[1]^[13] This reaction is not random but is precisely catalyzed by a class of non-heme iron enzymes known as Carotenoid Cleavage Dioxygenases (CCDs).^[14]^[15]

The Role of Carotenoid Cleavage Dioxygenase 1 (CCD1)

The key enzyme responsible for β -ionone synthesis is CCD1.^[1]^[4] This enzyme specifically targets and cleaves the 9,10 and 9',10' double bonds of the β -carotene molecule.^[11] The reaction requires molecular oxygen and results in the formation of two molecules of β -ionone and a C14 dialdehyde from a single β -carotene precursor. The expression and activity of CCD genes are often tightly regulated, linked to developmental stages (like fruit ripening and flower opening), circadian rhythms, and responses to environmental stress.^[16]^[17]

The Biosynthetic Pathway

The causality of this pathway is straightforward: the accumulation of the precursor, β -carotene, is a prerequisite for β -ionone production. Tissues rich in β -carotene, such as chromoplasts in ripening fruits and petals, are primary sites for its synthesis. The spatio-temporal expression of the CCD1 gene dictates when and where this conversion occurs.



FULL PROTOCOL TRUNCATED

To view exact molar ratios, purification steps, and HRP optimization data, please view the interactive version.

[Unlock Full Protocol on Website](#)

[Click to download full resolution via product page](#)

Caption: Enzymatic conversion of β -carotene to β -ionone by CCD1.

Biological Functions: A Molecule of Communication

β -ionone is not merely a metabolic byproduct; it is a potent signaling molecule that mediates a plant's interaction with its environment.[1]

- **Pollinator Attraction:** In many flowering species, such as *Osmanthus fragrans* and *Petunia hybrida*, β -ionone is a key component of the floral scent bouquet that attracts pollinators, thereby ensuring successful reproduction.[1][4]
- **Herbivore and Pathogen Defense:** The release of β -ionone can act as a repellent or feeding deterrent to herbivores, such as the red-legged earth mite.[1] Furthermore, it has demonstrated antibacterial and fungicidal properties, contributing to the plant's innate immune response.[18] Recent studies show that pre-treatment with β -ionone can increase

resistance in plants like Arabidopsis and tomato against the necrotrophic fungus Botrytis cinerea.[6]

- Abiotic Stress Response: The synthesis and accumulation of β -ionone can be induced by abiotic stressors, particularly photooxidative stress.[1] The enzymatic or reactive oxygen species (ROS)-mediated oxidation of β -carotene can lead to its formation, suggesting a role in the plant's broader stress response network.[14]



FULL PROTOCOL TRUNCATED

To view exact molar ratios, purification steps, and HRP optimization data, please view the interactive version.

[Unlock Full Protocol on Website](#)

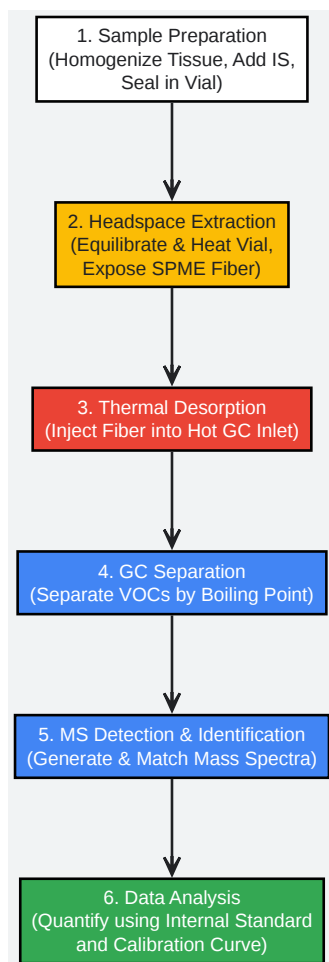

[Click to download full resolution via product page](#)

Need Custom Synthesis?

BenchChem offers custom synthesis for rare earth carbides and specific isotopic labeling.

Email: info@benchchem.com or [Request Quote Online](#).

Sources

- 1. β -Ionone: Its Occurrence and Biological Function and Metabolic Engineering - PMC [[pmc.ncbi.nlm.nih.gov](https://pubmed.ncbi.nlm.nih.gov/)]
- 2. Ionone - Wikipedia [en.wikipedia.org]
- 3. consolidated-chemical.com [consolidated-chemical.com]
- 4. encyclopedia.pub [encyclopedia.pub]

- [5. researchgate.net \[researchgate.net\]](#)
- [6. The apocarotenoid \$\beta\$ -ionone regulates the transcriptome of Arabidopsis thaliana and increases its resistance against Botrytis cinerea - PubMed \[pubmed.ncbi.nlm.nih.gov\]](#)
- [7. Research Progress on the Biosynthesis and Regulation of \$\beta\$ -Ionone - Oreate AI Blog \[oreateai.com\]](#)
- [8. researchgate.net \[researchgate.net\]](#)
- [9. mdpi.com \[mdpi.com\]](#)
- [10. Production of \$\beta\$ -ionone by combined expression of carotenogenic and plant CCD1 genes in Saccharomyces cerevisiae - PMC \[pmc.ncbi.nlm.nih.gov\]](#)
- [11. researchgate.net \[researchgate.net\]](#)
- [12. beta-Ionone | The Fragrance Conservatory \[fragranceconservatory.com\]](#)
- [13. \$\beta\$ -Ionone: Its Occurrence and Biological Function and Metabolic Engineering \[agris.fao.org\]](#)
- [14. Frontiers | Identification of the carotenoid cleavage dioxygenase genes and functional analysis reveal DoCCD1 is potentially involved in beta-ionone formation in Dendrobium officinale \[frontiersin.org\]](#)
- [15. carotenoid cleavage dioxygenase: Topics by Science.gov \[science.gov\]](#)
- [16. Frontiers | Metabolism of Carotenoids and \$\beta\$ -Ionone Are Mediated by Carotenogenic Genes and PpCCD4 Under Ultraviolet B Irradiation and During Fruit Ripening \[frontiersin.org\]](#)
- [17. Advances on the biosynthesis of \$\beta\$ -ionone and its key rate-limiting enzyme carotenoid cleavage dioxygenases \[yndxxb.ynu.edu.cn\]](#)
- [18. Influence of \$\beta\$ -Ionone in the Phytotoxicity of the Rhizome of Iris pallida Lam \[mdpi.com\]](#)
- [To cite this document: BenchChem. \[A Technical Guide to \$\beta\$ -Ionone: Biosynthesis, Function, and Analysis in Flora\]. BenchChem, \[2026\]. \[Online PDF\]. Available at: \[https://www.benchchem.com/product/b089335#beta-ionone-as-a-volatile-organic-compound-in-fruits-and-flowers\]](#)

Disclaimer & Data Validity:

The information provided in this document is for Research Use Only (RUO) and is strictly not intended for diagnostic or therapeutic procedures. While BenchChem strives to provide

accurate protocols, we make no warranties, express or implied, regarding the fitness of this product for every specific experimental setup.

Technical Support: The protocols provided are for reference purposes. Unsure if this reagent suits your experiment?

Need Industrial/Bulk Grade? [Request Custom Synthesis Quote](#)

BenchChem

Our mission is to be the trusted global source of essential and advanced chemicals, empowering scientists and researchers to drive progress in science and industry.

Contact

Address: 3281 E Guasti Rd

Ontario, CA 91761, United States

Phone: (601) 213-4426

Email: info@benchchem.com

[Contact our Ph.D. Support Team for a compatibility check](#)