

# Lithium Chloride's role in developmental biology research

**Author:** BenchChem Technical Support Team. **Date:** May 2026

## Compound of Interest

Compound Name: *Lithium Chloride*

CAS No.: 59217-69-5

Cat. No.: B8822488

[Get Quote](#)

An In-depth Technical Guide to **Lithium Chloride's** Role in Developmental Biology Research

## Abstract

**Lithium chloride** (LiCl), a simple inorganic salt, is a remarkably potent and widely utilized tool in developmental biology. For decades, its teratogenic effects have been leveraged by researchers to dissect the fundamental molecular signaling pathways that govern embryonic patterning and cell fate determination. This technical guide provides an in-depth exploration of LiCl's mechanism of action, its classic phenotypic consequences in key model organisms, and detailed, field-proven protocols for its application. We delve into the causality behind experimental choices, address critical limitations, and position LiCl as an indispensable, albeit classic, pharmacological agent for probing the canonical Wnt/ $\beta$ -catenin signaling pathway. This document is intended for researchers, scientists, and drug development professionals seeking to understand and apply LiCl in their experimental paradigms.

## The Core Mechanism: Inhibition of Glycogen Synthase Kinase 3 (GSK-3)

The profound developmental effects of **lithium chloride** are primarily attributed to its direct inhibition of Glycogen Synthase Kinase 3 (GSK-3), a highly conserved serine/threonine kinase. [1][2] GSK-3 is a constitutively active enzyme that acts as a critical negative regulator in numerous signaling pathways, most notably the canonical Wnt/ $\beta$ -catenin pathway, which is central to embryonic development. [3][4][5]

### The Wnt/ $\beta$ -catenin Signaling Cascade: A Tale of Two States

The Wnt pathway's default state is "Off." In the absence of a Wnt ligand, GSK-3 is part of a cytoplasmic "destruction complex" along with Axin, Adenomatous Polyposis Coli (APC), and Casein Kinase 1 (CK1). [6][7] This complex sequentially phosphorylates the transcriptional co-activator  $\beta$ -catenin, marking it for ubiquitination and subsequent proteasomal degradation. This ensures that cytoplasmic  $\beta$ -catenin levels remain low, and Wnt target genes are kept silent by T-cell factor/lymphoid enhancer-binding factor (TCF/LEF) transcription factors, which act as repressors in the nucleus. [6][8]

When a Wnt ligand binds to its Frizzled (Fz) and LRP5/6 co-receptors, the destruction complex is recruited to the plasma membrane and inactivated. [7] This inactivation prevents the phosphorylation of  $\beta$ -catenin.

Lithium's Intervention: LiCl acts as a direct inhibitor of GSK-3, effectively mimicking the Wnt "On" signal. [9][10] By inhibiting GSK-3, LiCl prevents the phosphorylation and degradation of  $\beta$ -catenin. [11] As a result, stabilized  $\beta$ -catenin accumulates in the cytoplasm, translocates to the nucleus, displaces co-repressors (like Groucho) from TCF/LEF transcription factors, and activates the expression of Wnt target genes. [6][8][12] These target genes are crucial for establishing the dorsal axis, specifying cell fates, and controlling cell proliferation during embryogenesis.

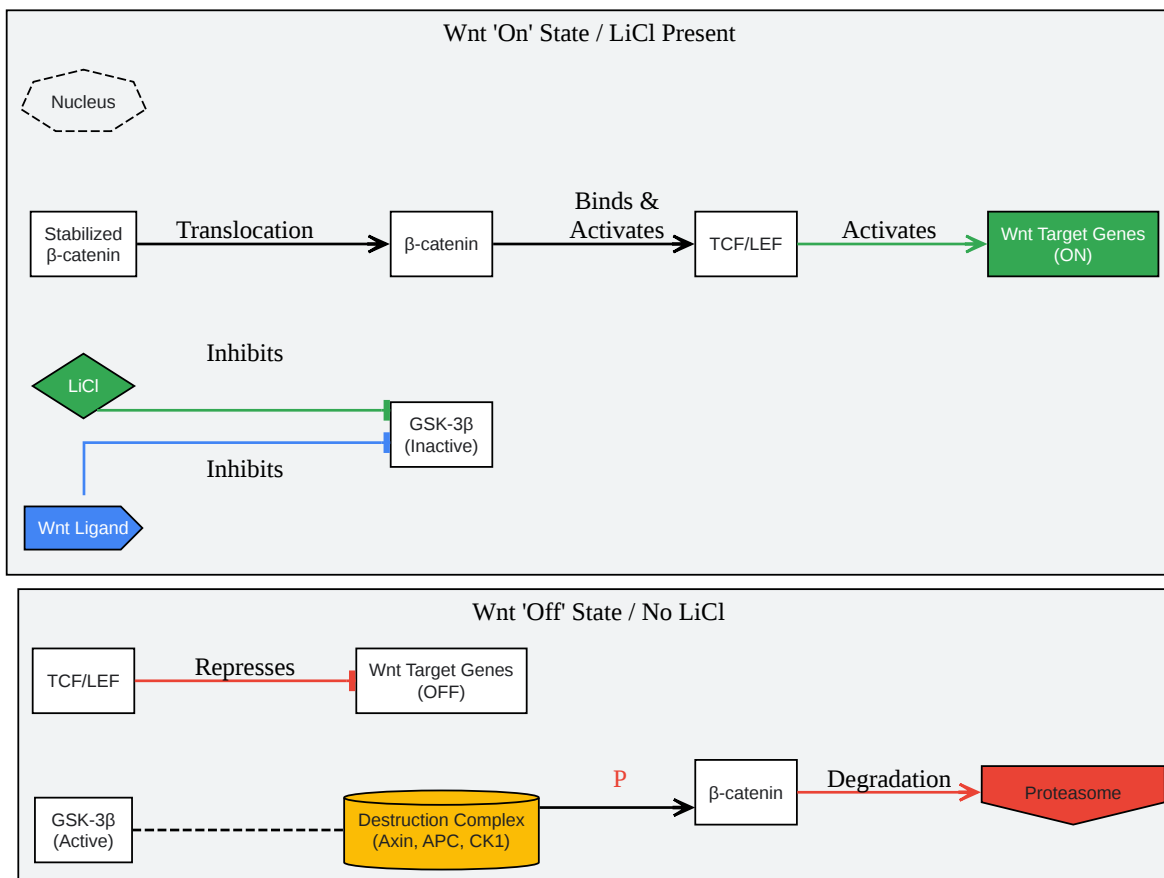

[Click to download full resolution via product page](#)

Caption: The Wnt/β-catenin signaling pathway with LiCl intervention.

## Phenotypic Consequences: Dorsalization and Cell Fate Respecification

The artificial activation of Wnt signaling by LiCl leads to dramatic and predictable changes in embryonic development, most famously the "dorsalization" or "anteriorization" of embryos. This occurs because the dorsal side of the vertebrate embryo is established by a high concentration of nuclear  $\beta$ -catenin. LiCl treatment effectively mimics this signal throughout the entire embryo.

- **Xenopus laevis (African Clawed Frog):** Treatment of early cleavage-stage *Xenopus* embryos with LiCl is a classic experiment demonstrating its dorsalizing effect.<sup>[13]</sup> Ventral cells, which would normally form ventral structures like the belly, are respecified to adopt dorsal fates. This results in embryos that are hyperdorsalized, often exhibiting duplicated axes, enlarged heads, and radial cement glands and eyes.<sup>[13][14]</sup>
- **Danio rerio (Zebrafish):** In zebrafish, LiCl treatment during the cleavage stage also causes dorsalization, expanding the "shield" region (the fish equivalent of the amphibian dorsal organizer). This perturbation of the dorsal-ventral axis leads to severe defects, including twisted posterior structures, cyclopia, and other anterior abnormalities.<sup>[15][16]</sup> The specific phenotype is highly dependent on the timing of exposure.<sup>[15][16]</sup>
- **Sea Urchins:** In sea urchin embryos, LiCl treatment causes a respecification of cell fate, transforming presumptive ectodermal cells into endodermal cells.<sup>[16]</sup>
- **Stem Cells:** Beyond whole embryos, LiCl is used to direct the differentiation of stem cells. For instance, it can promote the proliferation of neural stem cells and influence their fate, often enhancing neuronal differentiation over glial fates by activating the Wnt pathway.<sup>[9][17]</sup>

## Experimental Protocols and Methodologies

The key to successful LiCl experiments is precise control over concentration and the timing of exposure. The developmental window for affecting primary axis formation is typically very early and brief.

### Generalized Experimental Workflow

Caption: A generalized workflow for LiCl treatment of embryos.

### Protocol 1: Dorsalization of *Xenopus laevis* Embryos

This protocol is adapted from methodologies described by Sive et al. (2000) and Kao & Elison (1988).[\[13\]](#)

- **Embryo Preparation:** Collect *Xenopus* embryos shortly after fertilization. Dejelly the embryos using a 2% cysteine solution (pH 7.8-8.0) when they are at or before the 32-cell stage. Rinse thoroughly with 0.1x Marc's Modified Ringer's (MMR) solution.
- **Solution Preparation:** Prepare a 0.3 M LiCl solution in 0.1x MMR. Prepare a control dish containing only 0.1x MMR.
- **Treatment:** Using a transfer pipette, move healthy embryos (at the 32- to 64-cell stage) into the 0.3 M LiCl solution.
- **Incubation:** Incubate the embryos at room temperature (18-22°C) for exactly 10 minutes. Gentle swirling can ensure even exposure.
- **Washing:** Promptly remove the embryos from the LiCl solution and wash them thoroughly by transferring them through at least three successive dishes of fresh 0.1x MMR. This step is critical to stop the treatment.
- **Culture and Analysis:** Culture the washed embryos in 0.1x MMR at 18-22°C. Observe the formation of the blastopore lip at the gastrula stage and score for dorsalized phenotypes (e.g., radialized heads, duplicated axes) at the tadpole stage (24-48 hours post-treatment).

## Protocol 2: Axis Perturbation in Zebrafish (*Danio rerio*) Embryos

This protocol is based on methodologies described by Stachel et al. (1993) and others.[\[10\]](#)[\[15\]](#)  
[\[16\]](#)

- **Embryo Preparation:** Collect zebrafish embryos after spawning and allow them to develop at 28.5°C to the desired stage. For dorsal-ventral axis defects, treatment between the 64-cell and sphere stage (2-4 hours post-fertilization, hpf) is effective.
- **Solution Preparation:** Prepare a range of LiCl concentrations (e.g., 0.15 M, 0.3 M, 0.45 M) in standard E3 embryo medium. Prepare a control dish with E3 medium only.

- Treatment: Transfer 20-30 embryos into each LiCl solution and the control dish.
- Incubation: Incubate the embryos at 28.5°C for 10 minutes.
- Washing: Remove the embryos and wash them three times with fresh E3 medium to remove all traces of LiCl.
- Culture and Analysis: Return the embryos to a fresh dish of E3 medium and incubate at 28.5°C. Observe and document phenotypes at 24-30 hpf, scoring for degrees of dorsalization, cyclopia, reduced eyes, and posterior axis defects.[15]

## Comparative Treatment Parameters

Model Organism	Developmental Stage	LiCl Concentration	Duration	Resulting Phenotype
Xenopus laevis	32- to 64-cell	0.3 M	5-10 min	Hyperdorsalization, axis duplication[11] [13]
Danio rerio	Cleavage (2-4 hpf)	0.15 - 0.3 M	10 min	Dorsalization, expanded shield, eye defects[15] [16]
Danio rerio	Gastrula (>6 hpf)	0.15 - 0.3 M	10 min	Anterior defects (e.g., microcephaly) [16]
Sea Urchin	Cleavage	Varies	Varies	Endoderm induction from ectoderm[16]

## Limitations and Critical Considerations

While powerful, LiCl is a blunt instrument. Researchers must be aware of its limitations to ensure rigorous and well-interpreted experiments.

- **Toxicity:** The therapeutic window for LiCl is narrow. Concentrations that are too high or exposure times that are too long will lead to general toxicity and developmental arrest rather than specific patterning defects.[18]
- **Lack of Specificity:** Although GSK-3 is the primary target for its developmental effects, LiCl is not entirely specific. It is also a known inhibitor of the inositol polyphosphate 1-phosphatase (IPP) and inositol monophosphatase (IMPase), which can disrupt the phosphoinositide signaling pathway.[19][20] While the dorsalizing phenotype is strongly linked to GSK-3 inhibition, researchers should validate key findings using more specific, modern GSK-3 inhibitors (e.g., CHIR99021, BIO) or genetic tools like morpholinos or CRISPR/Cas9 to target GSK-3 directly.
- **Timing is Everything:** As shown in the data table, the phenotypic outcome is critically dependent on the developmental stage of treatment.[21] Treatment during cleavage stages affects the primary dorsal-ventral axis, whereas later treatments can perturb the development of specific anterior structures like the eyes and brain without causing a full axis duplication.[15][16] This temporal sensitivity is a crucial experimental variable that must be precisely controlled.

## Conclusion

**Lithium chloride** remains a cornerstone tool in the field of developmental biology. Its ability to potently and reliably inhibit GSK-3 provides an inexpensive and accessible method for activating the canonical Wnt/ $\beta$ -catenin pathway. This allows researchers to probe the fundamental mechanisms of axis formation, cell fate specification, and organogenesis. While its lack of absolute specificity requires careful experimental design and validation with modern tools, its utility in generating foundational hypotheses and its decades of well-documented effects ensure its place in the developmental biologist's toolkit. By understanding its core mechanism and applying it with precision, scientists can continue to uncover the intricate signaling networks that build an embryo.

## References

- Title: Wnt signaling pathway diagram Source: The Wnt Homepage URL:[[Link](#)]

- Title: The effects of different concentrations of **lithium chloride** on the development of zebrafish embryos Source: Millersville University URL:[[Link](#)]
- Title: Effect of Lithium on Xenopus development Source: Reed College URL:[[Link](#)]
- Title: Lithium-induced teratogenesis in frog embryos prevented by a polyphosphoinositide cycle intermediate or a diacylglycerol analog Source: PubMed URL:[[Link](#)]
- Title: Schematic Diagram of Wnt/ $\beta$ -catenin Signaling Pathway. Source: ResearchGate URL:[[Link](#)]
- Title: Teratogenic and developmental effects of lithium Source: PubMed URL:[[Link](#)]
- Title: Epigenetic alterations brought about by lithium treatment disrupt mouse embryo development Source: PubMed URL:[[Link](#)]
- Title: Dorsalization of mesoderm induction by lithium Source: PubMed URL:[[Link](#)]
- Title: Schematic representation of the Wnt/ $\beta$ -catenin signaling pathway and the... Source: ResearchGate URL:[[Link](#)]
- Title: Teratogenic and Developmental Effects of Lithium Source: Bentham Science Publisher URL:[[Link](#)]
- Title: Pharmacological and Toxicological Effects of Lithium in Zebrafish Source: PubMed Central URL:[[Link](#)]
- Title: **Lithium chloride** promotes proliferation of neural stem cells in vitro, possibly by triggering the Wnt signaling pathway Source: PubMed Central URL:[[Link](#)]
- Title: Lithium perturbation and goosecoid expression identify a dorsal specification pathway in the pregastrula zebrafish Source: Development (Company of Biologists Journals) URL:[[Link](#)]
- Title: GSK3b-inhibitor **lithium chloride** enhances activation of Wnt canonical signaling and osteoblast differentiation on hydrophilic titanium surfaces Source: PubMed URL:[[Link](#)]

- Title: The GSK3 kinase inhibitor lithium produces unexpected hyperphosphorylation of  $\beta$ -catenin, a GSK3 substrate, in human glioblastoma cells Source: Biology Open (Company of Biologists Journals) URL:[[Link](#)]
- Title: Lithium and Therapeutic Targeting of GSK-3 Source: MDPI URL:[[Link](#)]
- Title: Wnt Signaling Pathway Source: Creative Diagnostics URL:[[Link](#)]
- Title: Lithium Treatment to Disrupt Wnt Signaling Source: Zebrafish in the Classroom URL:[[Link](#)]
- Title: GSK-3 and Wnt Signaling in Neurogenesis and Bipolar Disorder Source: Frontiers in Molecular Neuroscience URL:[[Link](#)]
- Title: Activation of Wnt/ $\beta$ -catenin signaling by **lithium chloride** attenuates d-galactose-induced neurodegeneration in the auditory cortex of a rat model of aging Source: PubMed Central URL:[[Link](#)]
- Title: GSK3 Function in the Brain during Development, Neuronal Plasticity, and Neurodegeneration Source: PubMed Central URL:[[Link](#)]
- Title: Glycogen synthase kinase-3 beta Source: Wikipedia URL:[[Link](#)]
- Title: The mode of action of lithium salts in amphibian development Source: ResearchGate URL:[[Link](#)]
- Title: Functions of GSK-3 Signaling in Development of the Nervous System Source: Frontiers in Molecular Neuroscience URL:[[Link](#)]
- Title: A molecular mechanism for the effect of lithium on development Source: Harvard Department of Stem Cell and Regenerative Biology URL:[[Link](#)]
- Title: The effects of different concentrations of **lithium chloride** on the development Source: Antpedia URL:[[Link](#)]
- Title: Activation of Wnt Signaling Using **Lithium Chloride**: Inquiry-Based Undergraduate Laboratory Exercises Source: PubMed Central URL:[[Link](#)]

- Title: Glycogen Synthase Kinase-3 $\beta$  Source: Circulation Research (American Heart Association Journals) URL:[[Link](#)]
- Title: Glycogen Synthase Kinase 3 Beta (GSK3 $\beta$ ) at the Tip of Neuronal Development and Regeneration Source: ResearchGate URL:[[Link](#)]
- Title: The primary action of **lithium chloride** on morphogenesis in *Lymnaea stagnalis* Source: Development (Company of Biologists Journals) URL:[[Link](#)]
- Title: Transcriptomics of dorso-ventral axis determination in *Xenopus tropicalis* Source: PubMed Central URL:[[Link](#)]
- Title: Protocol for culturing and imaging of ectodermal cells from *Xenopus* Source: PubMed Central URL:[[Link](#)]
- Title: Morphological Changes in *Xenopus laevis* Embryos with Lithium and Evaluation of the Fetax Test Source: ResearchGate URL:[[Link](#)]
- Title: Effects of Lithium on Formation of the Larval Body Pattern of *Xenopus Laevis* Source: DergiPark URL:[[Link](#)]
- Title: Lithium influences differentiation and tissue-specific gene expression of mouse embryonic stem (ES) cells in vitro Source: PubMed URL:[[Link](#)]
- Title: Small molecule inhibitors of mammalian GSK-3 $\beta$  promote in vitro plant cell reprogramming and somatic embryogenesis in crop and forest species Source: PubMed Central URL:[[Link](#)]
- Title: Differential fate and functional outcome of **lithium chloride** primed adult neural progenitor cell transplants in a rat model of Huntington disease Source: PubMed URL:[[Link](#)]
- Title: Glycogen Synthase Kinase-3 Inhibitors: Preclinical and Clinical Focus on CNS-A Decade Onward Source: PubMed Central URL:[[Link](#)]
- Title: **Lithium chloride** inhibits cell survival, overcomes drug resistance, and triggers apoptosis in multiple myeloma via activation of the Wnt/ $\beta$ -catenin pathway Source: National Institutes of Health (NIH) URL:[[Link](#)]

- Title: Investigating lithium orotate's modulation of neural crest cell specification Source: Patsnap Eureka URL:[[Link](#)]
- Title: GSK-3 Inhibitors: Preclinical and Clinical Focus on CNS Source: Frontiers in Molecular Neuroscience URL:[[Link](#)]
- Title: Discovery of GSK3 $\beta$  Inhibitors through In Silico Prediction-and-Experiment Cycling Strategy, and Biological Evaluation Source: MDPI URL:[[Link](#)]
- Title: Novel Modality of GSK-3 Inhibition For Treating Neurodegeneration Source: Journal of Visualized Experiments (JoVE) URL:[[Link](#)]

### Need Custom Synthesis?

BenchChem offers custom synthesis for rare earth carbides and specific isotopic labeling.

Email: [info@benchchem.com](mailto:info@benchchem.com) or [Request Quote Online](#).

## Sources

- 1. [mdpi.com](https://www.mdpi.com) [[mdpi.com](https://www.mdpi.com)]
- 2. Klein PS, Melton DA. A molecular mechanism for the effect of lithium on development. Proc Natl Acad Sci U S A. 1996 Aug 06; 93(16):8455-9. | [HSCRB](https://hscrb.harvard.edu) [[hscrb.harvard.edu](https://hscrb.harvard.edu)]
- 3. [Frontiers](https://www.frontiersin.org) | GSK-3 and Wnt Signaling in Neurogenesis and Bipolar Disorder [[frontiersin.org](https://www.frontiersin.org)]
- 4. Glycogen synthase kinase-3 beta - Wikipedia [[en.wikipedia.org](https://en.wikipedia.org)]
- 5. [ahajournals.org](https://www.ahajournals.org) [[ahajournals.org](https://www.ahajournals.org)]
- 6. Wnt signaling pathway diagram | The WNT Homepage [[wnt.stanford.edu](https://wnt.stanford.edu)]
- 7. Wnt/ $\beta$ -Catenin Signaling | Cell Signaling Technology [[cellsignal.com](https://www.cellsignal.com)]
- 8. [creative-diagnostics.com](https://www.creative-diagnostics.com) [[creative-diagnostics.com](https://www.creative-diagnostics.com)]
- 9. Lithium chloride promotes proliferation of neural stem cells in vitro, possibly by triggering the Wnt signaling pathway - PMC [[pmc.ncbi.nlm.nih.gov](https://pubmed.ncbi.nlm.nih.gov)]
- 10. [lithiumindex](https://www.zfic.org) [[zfic.org](https://www.zfic.org)]
- 11. Transcriptomics of dorso-ventral axis determination in *Xenopus tropicalis* - PMC [[pmc.ncbi.nlm.nih.gov](https://pubmed.ncbi.nlm.nih.gov)]

- [12. Activation of Wnt/ \$\beta\$ -catenin signaling by lithium chloride attenuates d-galactose-induced neurodegeneration in the auditory cortex of a rat model of aging - PMC \[pmc.ncbi.nlm.nih.gov\]](#)
- [13. Effect of Lithium on Xenopus development \[sites.millersville.edu\]](#)
- [14. Dorsalization of mesoderm induction by lithium - PubMed \[pubmed.ncbi.nlm.nih.gov\]](#)
- [15. journals.biologists.com \[journals.biologists.com\]](#)
- [16. sites.millersville.edu \[sites.millersville.edu\]](#)
- [17. Differential fate and functional outcome of lithium chloride primed adult neural progenitor cell transplants in a rat model of Huntington disease - PubMed \[pubmed.ncbi.nlm.nih.gov\]](#)
- [18. researchgate.net \[researchgate.net\]](#)
- [19. Lithium-induced teratogenesis in frog embryos prevented by a polyphosphoinositide cycle intermediate or a diacylglycerol analog - PubMed \[pubmed.ncbi.nlm.nih.gov\]](#)
- [20. Teratogenic and developmental effects of lithium - PubMed \[pubmed.ncbi.nlm.nih.gov\]](#)
- [21. researchgate.net \[researchgate.net\]](#)
- To cite this document: BenchChem. [Lithium Chloride's role in developmental biology research]. BenchChem, [2026]. [Online PDF]. Available at: [\[https://www.benchchem.com/product/b8822488/docs#lithium-chloride-s-role-in-developmental-biology-research\]](https://www.benchchem.com/product/b8822488/docs#lithium-chloride-s-role-in-developmental-biology-research)

---

### Disclaimer & Data Validity:

The information provided in this document is for Research Use Only (RUO) and is strictly not intended for diagnostic or therapeutic procedures. While BenchChem strives to provide accurate protocols, we make no warranties, express or implied, regarding the fitness of this product for every specific experimental setup.

**Technical Support:** The protocols provided are for reference purposes. Unsure if this reagent suits your experiment?

**Need Industrial/Bulk Grade?** [Request Custom Synthesis Quote](#)

# BenchChem

Our mission is to be the trusted global source of essential and advanced chemicals, empowering scientists and researchers to drive progress in science and industry.

## Contact

Address: 3281 E Guasti Rd

Ontario, CA 91761, United States

Phone: (601) 213-4426

Email: [info@benchchem.com](mailto:info@benchchem.com)

[Contact our Ph.D. Support Team for a compatibility check](#)