

Application Note: Quantification of Theaflavin 3,3'-digallate using HPLC-DAD

Author: BenchChem Technical Support Team. **Date:** April 2026

Compound of Interest

Compound Name: *Theaflavin 3,3'-digallate*

Cat. No.: *B8816235*

[Get Quote](#)

Introduction

Theaflavin 3,3'-digallate (TF3) is a key bioactive polyphenol found in black tea, formed during the enzymatic oxidation of catechins during fermentation.[1] It significantly contributes to the color and astringency of black tea and is studied for its potential health benefits, including antioxidant and anti-inflammatory properties.[1] Accurate and reliable quantification of TF3 is essential for quality control in the tea industry, standardization of botanical extracts, and for researchers in drug development exploring its therapeutic potential.[1] This application note details a robust High-Performance Liquid Chromatography with Diode-Array Detection (HPLC-DAD) method for the precise quantification of **Theaflavin 3,3'-digallate**.

Principle of the Method

High-Performance Liquid Chromatography (HPLC) is a powerful analytical technique used to separate, identify, and quantify components in a mixture. This method utilizes a reversed-phase HPLC system, where the stationary phase is nonpolar (e.g., C18 or C12) and the mobile phase is polar. The separation is based on the differential partitioning of the analytes between the two phases. A Diode-Array Detector (DAD) is employed for detection, allowing for the simultaneous acquisition of absorbance spectra over a range of wavelengths. This feature aids in peak

identification and purity assessment. Quantification is achieved by comparing the peak area of **Theaflavin 3,3'-digallate** in a sample to a calibration curve generated from reference standards.

Experimental Protocols

This section provides a detailed protocol for the quantification of **Theaflavin 3,3'-digallate** in black tea samples.

1. Materials and Reagents

- **Theaflavin 3,3'-digallate** reference standard ($\geq 98\%$ purity)[2]
- Acetonitrile (HPLC grade)[3]
- Water (Ultrapure)
- Acetic Acid (Glacial, HPLC grade) or Orthophosphoric Acid (HPLC grade) or Trifluoroacetic Acid (HPLC grade)
- Methanol (HPLC grade) or Ethanol (for extraction)
- Ascorbic Acid (optional, for extraction)
- Black tea samples (finely ground)

2. Instrumentation and Chromatographic Conditions

- HPLC System: An HPLC system equipped with a quaternary or binary pump, autosampler, column oven, and a Diode-Array Detector (DAD).
- Column: A reversed-phase C18 column (e.g., 4.6 mm i.d. x 150 mm, 5 μm) or a C12 column (e.g., 4.6 mm x 250 mm, 4 μm) can be used.
- Mobile Phase:
 - Mobile Phase A: 0.1% v/v orthophosphoric acid in ultrapure water. Alternatively, 2% aqueous acetic acid or 0.01% trifluoroacetic acid in water can be used.

- Mobile Phase B: 0.1% v/v orthophosphoric acid in acetonitrile.
- Elution Program: A gradient elution is typically employed. An example gradient is as follows: start at 10% B, increase to 20% B over 10 minutes, hold for 6 minutes, increase to 30% B over 8 minutes, then increase to 45% B over 8 minutes. The column should be re-equilibrated to initial conditions between injections.
- Flow Rate: 1.0 mL/min
- Column Temperature: 32-40°C
- Injection Volume: 10 µL
- Detection Wavelength: 280 nm for quantification. A full spectrum scan (e.g., 200-700 nm) can be used for peak identification.

3. Preparation of Standard Solutions

- Stock Standard Solution (e.g., 1000 µg/mL): Accurately weigh 10 mg of **Theaflavin 3,3'-digallate** reference standard and dissolve it in 10 mL of methanol in a volumetric flask.
- Working Standard Solutions: Prepare a series of working standard solutions (e.g., 5, 10, 25, 50, 100 µg/mL) by diluting the stock solution with the mobile phase A. These solutions are used to construct the calibration curve.

4. Sample Preparation

- Extraction from Black Tea:
 - Weigh 1.0 g of finely ground black tea powder.
 - Add 40-50 mL of 50-70% aqueous ethanol or methanol. The addition of 2% ascorbic acid to the extraction solvent can help prevent oxidation.
 - Extract using ultrasonication for a specified period.
 - Centrifuge the extract (e.g., 3000 rpm for 10 minutes).

- Collect the supernatant. The extraction can be repeated two more times, and the supernatants pooled.
- Solid-Phase Extraction (SPE) for Sample Clean-up (Optional but Recommended):
 - Dilute the ethanol extract 4-fold with distilled water.
 - Apply the diluted extract to a C18 SPE cartridge.
 - Rinse the cartridge with water, followed by 15% ethanol to remove interferences.
 - Elute the theaflavins with 40% ethanol.
 - Concentrate the eluate before HPLC analysis.
- Final Preparation: Filter the final extract through a 0.45 μm syringe filter before injection into the HPLC system.

5. Data Analysis and Quantification

- Calibration Curve: Inject the working standard solutions and record the peak areas. Construct a calibration curve by plotting the peak area versus the concentration of **Theaflavin 3,3'-digallate**. A linear regression analysis should yield a correlation coefficient (r^2) of ≥ 0.999 .
- Quantification: Inject the prepared sample solution and identify the **Theaflavin 3,3'-digallate** peak based on its retention time compared to the standard. Calculate the concentration of **Theaflavin 3,3'-digallate** in the sample using the regression equation from the calibration curve.

6. Method Validation

To ensure the reliability of the results, the analytical method should be validated for the following parameters:

- Linearity: Assessed by the correlation coefficient (r^2) of the calibration curve over a defined concentration range.

- Accuracy: Determined by performing recovery studies on spiked samples.
- Precision: Evaluated by determining the intra-day and inter-day precision, expressed as the relative standard deviation (RSD).
- Limit of Detection (LOD) and Limit of Quantification (LOQ): Determined based on the signal-to-noise ratio (S/N), typically 3 for LOD and 10 for LOQ.

Quantitative Data Summary

The following tables summarize typical quantitative data for the HPLC-DAD analysis of **Theaflavin 3,3'-digallate** and other theaflavins.

Table 1: Chromatographic and Validation Parameters

Parameter	Value	Reference
Linearity (r^2)	0.9990 - 0.9992	
LOD	0.1 - 0.3 mg/L	
LOQ	0.4 - 1.1 mg/L	
Recovery	95.5 - 105.4%	
Precision (RSD)	< 1.5%	

Table 2: Example HPLC-DAD Conditions

Parameter	Method 1	Method 2	Method 3
Column	C12 (4.6 x 250 mm, 4 μ m)	ODS C18 (4.6 mm i.d. x 150 mm)	RP-18e (2 μ m particle size)
Mobile Phase A	Water with 0.01% TFA	Aqueous Acetic Acid (2%)	Not explicitly stated
Mobile Phase B	Acetonitrile with 0.01% TFA	Acetonitrile-Ethyl Acetate (21:3, v/v)	Not explicitly stated
Flow Rate	Not explicitly stated	Not explicitly stated	1.5 mL/min
Column Temp.	Not explicitly stated	40°C	35°C
Detection λ	280 nm	280 nm	280 nm
Run Time	~7 min	Not explicitly stated	~8 min

Visualizations

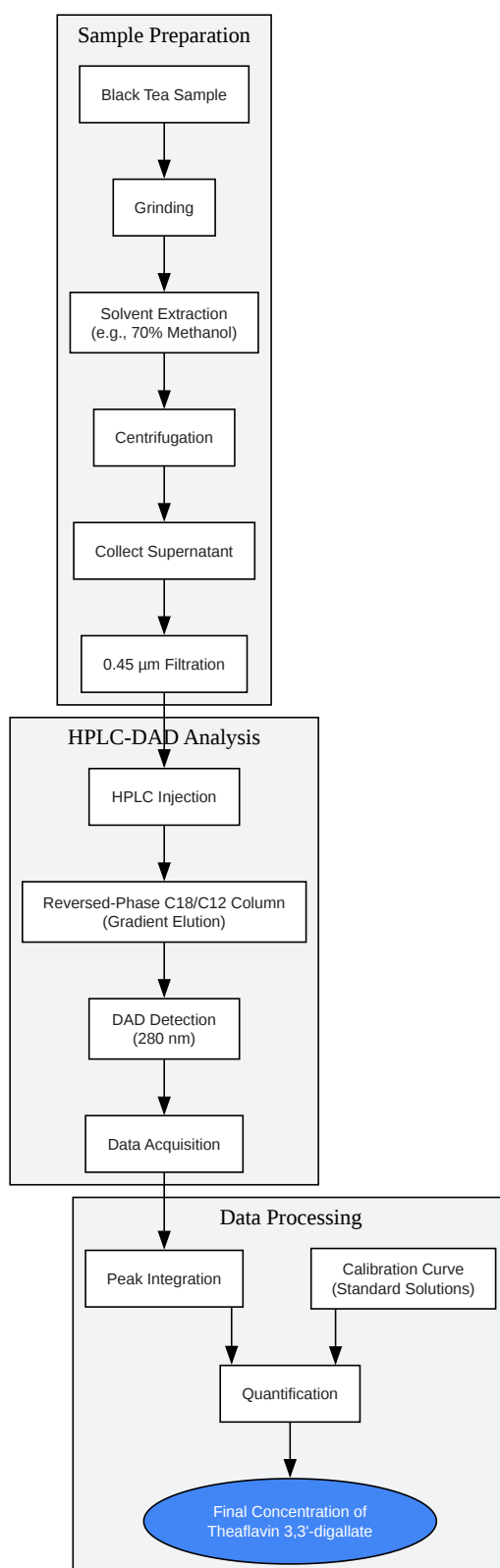

[Click to download full resolution via product page](#)

Caption: Experimental workflow for **Theaflavin 3,3'-digallate** quantification.

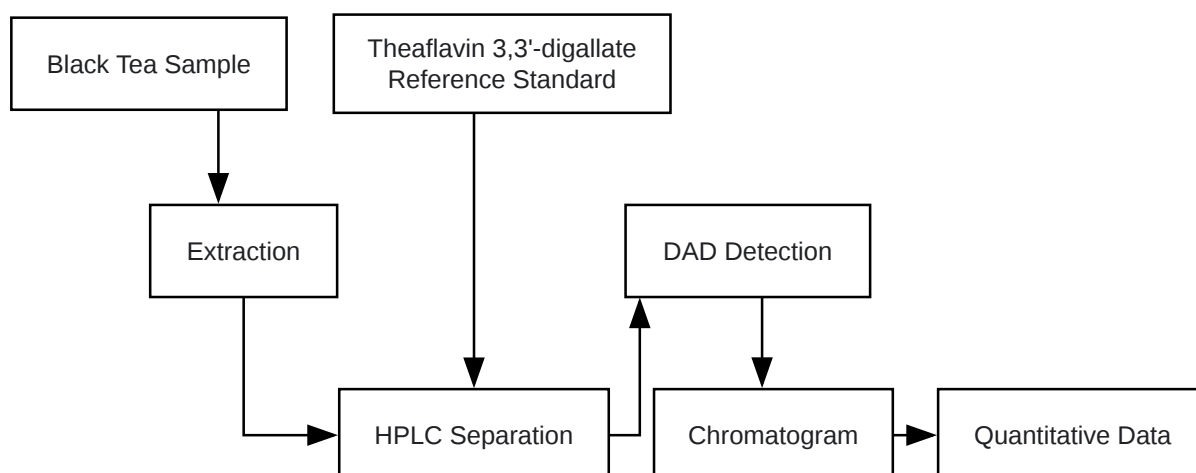

[Click to download full resolution via product page](#)

Caption: Logical relationship of the analytical process.

Need Custom Synthesis?

BenchChem offers custom synthesis for rare earth carbides and specific isotopic labeling.

Email: info@benchchem.com or [Request Quote Online](#).

References

- [1. benchchem.com \[benchchem.com\]](https://www.benchchem.com)
- [2. mro.massey.ac.nz \[mro.massey.ac.nz\]](https://mro.massey.ac.nz)
- [3. Determination of theaflavins including methylated theaflavins in black tea leaves by solid-phase extraction and HPLC analysis - PubMed \[pubmed.ncbi.nlm.nih.gov\]](https://pubmed.ncbi.nlm.nih.gov)
- To cite this document: BenchChem. [Application Note: Quantification of Theaflavin 3,3'-digallate using HPLC-DAD]. BenchChem, [2026]. [Online PDF]. Available at: [\[https://www.benchchem.com/product/b8816235/docs#application-note-quantification-of-theaflavin-3-3-digallate-using-hplc-dad\]](https://www.benchchem.com/product/b8816235/docs#application-note-quantification-of-theaflavin-3-3-digallate-using-hplc-dad)

Disclaimer & Data Validity:

The information provided in this document is for Research Use Only (RUO) and is strictly not intended for diagnostic or therapeutic procedures. While BenchChem strives to provide

accurate protocols, we make no warranties, express or implied, regarding the fitness of this product for every specific experimental setup.

Technical Support: The protocols provided are for reference purposes. Unsure if this reagent suits your experiment?

Need Industrial/Bulk Grade? [Request Custom Synthesis Quote](#)

BenchChem

Our mission is to be the trusted global source of essential and advanced chemicals, empowering scientists and researchers to drive progress in science and industry.

Contact

Address: 3281 E Guasti Rd

Ontario, CA 91761, United States

Phone: (601) 213-4426

Email: info@benchchem.com

[Contact our Ph.D. Support Team for a compatibility check](#)