

Advanced Coordination Dynamics of Rhodium(I) Acetate Complexes

Author: BenchChem Technical Support Team. **Date:** May 2026

Compound of Interest

Compound Name: *rhodium(I) acetate*

Cat. No.: *B8808476*

[Get Quote](#)

From Structural Precursors to Asymmetric Catalysis Part 1: The Rhodium(I) vs. Rhodium(II) Distinction

Executive Summary: In drug development and advanced organometallics, "Rhodium Acetate" is a term often shrouded in ambiguity. It is critical to distinguish between the two primary oxidation states, as their geometries and catalytic applications are diametrically opposed.

This guide focuses exclusively on **Rhodium(I) Acetate** complexes (e.g.,

), which serve as the foundational precursors for asymmetric hydrogenation and C-H activation.

Feature	Rhodium(I) Acetate	Rhodium(II) Acetate
Formula		
Geometry	Square Planar ()	Octahedral / Lantern ()
Bonding	No Metal-Metal Bond (typically)	Single Rh-Rh Bond
Primary Use	Precursor for Chiral Hydrogenation	Cyclopropanation, Carbene Transfer
Ligand Role	Acetate is a leaving group or internal base	Acetate is a stabilizing scaffold

Part 2: Coordination Geometry & Structural Dynamics

The core of Rh(I) chemistry is the

electron configuration, which dictates a square planar coordination sphere. In

(Di- μ -acetatobis(1,5-cyclooctadiene)dirhodium(I)), the geometry is defined by the interplay between the bidentate diene and the bridging carboxylates.

1. The Bridging Architecture

Unlike the planar chloride-bridged dimer

, the acetate-bridged variant often adopts a "bent" or "folded" conformation along the bridging axis.

- **Acetate Bite Angle:** The carboxylate group () bridges the two Rh centers. Because the distance between the two oxygens is relatively fixed, it constrains the Rh-Rh distance.
- **Hemilability:** The Rh-O bond in these complexes is chemically "softer" than the Rh-P bonds formed in subsequent catalytic steps. This makes the acetate ligand hemilabile—it can dissociate from one metal center to open a coordination site (vacancy) without fully leaving the complex, or it can act as an intramolecular proton acceptor.

2. The "Rocking" Diene

The 1,5-cyclooctadiene (COD) ligand occupies two coordination sites (cis-configuration). The steric bulk of the COD ring protects the metal center from non-specific aggregation but is labile enough to be displaced by high-affinity chiral phosphines (e.g., BINAP, DIPAMP) during catalyst activation.

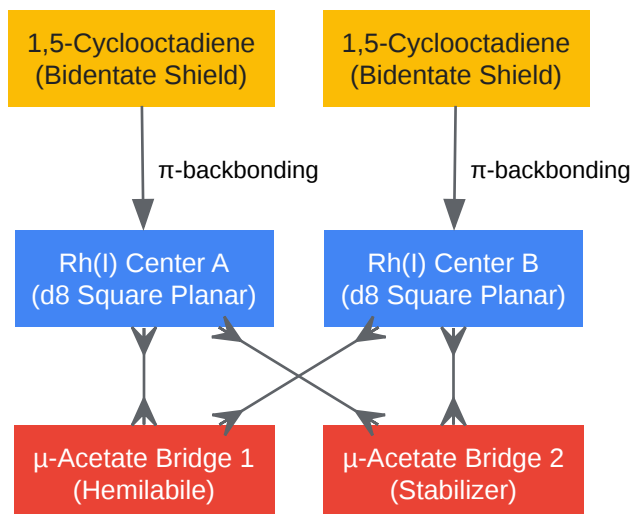

[Click to download full resolution via product page](#)

Figure 1: Connectivity map of the Rh(I) acetate dimer, highlighting the bridging nature of the acetate ligands which maintains the dimeric integrity while allowing for hemilabile opening.[1]

Part 3: Experimental Protocol (Synthesis & Activation)

Objective: Synthesize

from the commercially available Chloride dimer and activate it for catalysis.

Reagents:

- (Precursor)[2][3][4][5]
- Sodium Acetate (NaOAc) or Silver Acetate (AgOAc)
- Dichloromethane (DCM) or Methanol (degassed)
- Chiral Phosphine (e.g., L-DIPAMP) for activation

Step-by-Step Synthesis Workflow:

- Solvent Preparation: Degas Methanol (MeOH) using three freeze-pump-thaw cycles. Rh(I) species are moderately air-sensitive, but acetate variants are more robust than hydrides.
- Ligand Exchange (The "Salt Metathesis"):
 - Dissolve

(0.5 mmol) in DCM.
 - Add excess Sodium Acetate (NaOAc) (1.5 mmol) dissolved in MeOH.
 - Observation: The solution shifts from orange-yellow to a distinct lighter orange or brick-red depending on concentration.
 - Mechanism:[\[6\]](#)[\[7\]](#)[\[8\]](#)

is driven out by the higher affinity of

(if using AgOAc) or mass action (if using NaOAc).
- Purification:
 - Filter through Celite to remove NaCl or AgCl precipitates.
 - Evaporate solvent to dryness. Recrystallize from DCM/Hexanes.
 - Yield Verification:

shows a singlet for the acetate methyl group (~1.8-2.0 ppm) and multiplets for the COD protons.
- Catalyst Generation (In-Situ):
 - React the isolated

with a chiral diphosphine (

) in MeOH.

- Add a non-coordinating anion source (e.g.,

or

) if a cationic catalyst is required, OR rely on the basicity of the acetate for C-H activation pathways.

Part 4: Mechanistic Applications in Drug Development

The utility of Rh(I) acetate lies in its dual role:

- Asymmetric Hydrogenation: It serves as a clean precursor to cationic species. The acetate is easily displaced by strong acids or phosphines.
- C-H Activation (CMD Pathway): In the absence of strong acids, the acetate ligand acts as an internal base. It assists in the deprotonation of a substrate (Concerted Metalation-Deprotonation), a mechanism critical for functionalizing drug scaffolds without pre-activation.

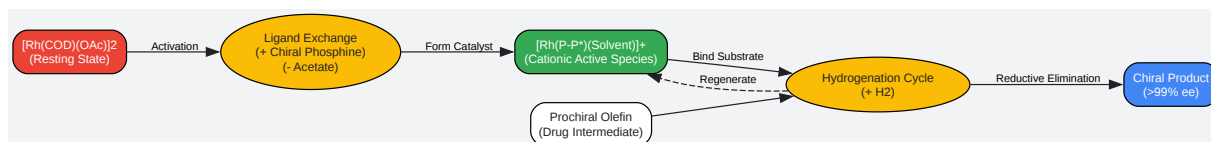

[Click to download full resolution via product page](#)

Figure 2: The activation pathway of Rh(I) acetate. Note that the acetate is removed to form the cationic hydrogenation catalyst, whereas it is retained for C-H activation cycles.

Part 5: Data Summary & Stability

Parameter	Value / Characteristic	Relevance
Oxidation State	+1	Required for oxidative addition of .
Coordination No.	4 (Square Planar)	Allows for axial attack of substrates.
Air Stability	Moderate (Solid), Poor (Solution)	Handle under Argon/Nitrogen.
Solubility	DCM, THF, MeOH	Compatible with standard organic synthesis.
Key NMR Signal	ppm (s, 3H)	Diagnostic for Acetate ligand.

References

- Synthesis and Structure of **Rhodium(I) Acetate** Dimers Giordano, G., & Crabtree, R. H. (1990). Di- μ -chloro-bis(η^4 -1,5-cyclooctadiene)dirhodium(I). Inorganic Syntheses. (Note: Describes the chloride parent; acetate is derived via metathesis described in standard organometallic texts).
- Mechanistic Role in Asymmetric Hydrogenation Knowles, W. S. (2003). Asymmetric Hydrogenations (Nobel Lecture). Advances in Synthesis and Catalysis.
- Acetate-Assisted C-H Activation (CMD Mechanism) Lapointe, D., & Fagnou, K. (2010). Overview of the Mechanistic Work on the Concerted Metallation–Deprotonation Pathway.
- Comparison of Rh(I) and Rh(II) Carboxylates Cotton, F. A., et al. (Multiple works on Metal-Metal bonds). (General structural reference for the Rh(II) contrast).

Need Custom Synthesis?

BenchChem offers custom synthesis for rare earth carbides and specific isotopic labeling.

Email: info@benchchem.com or [Request Quote Online](#).

Sources

- [1. pubs.acs.org \[pubs.acs.org\]](https://pubs.acs.org)
- [2. Synthesis of \[RhCl\(CO\)\(cyclopentadienone\)\]₂ from \[RhCl\(cod\)\]₂ and a 1,6-diyne under CO: application to Rh\(i\)-catalyzed tandem \[2+2+1\] carbonylative cycloaddition of diynes and Claisen rearrangement - Chemical Communications \(RSC Publishing\) \[pubs.rsc.org\]](#)
- [3. Enantiospecific Synthesis of Planar Chiral Rhodium and Iridium Cyclopentadienyl Complexes: Enabling Streamlined and Computer-Guided Access to Highly Selective Catalysts for Asymmetric C–H Functionalizations - PMC \[pmc.ncbi.nlm.nih.gov\]](#)
- [4. EP2303904B1 - Process for preparing cationic rhodium complexes - Google Patents \[patents.google.com\]](#)
- [5. Cyclooctadiene_rhodium_chloride_dimer \[chemeuropa.com\]](#)
- [6. pubs.acs.org \[pubs.acs.org\]](https://pubs.acs.org)
- [7. livrepository.liverpool.ac.uk \[livrepository.liverpool.ac.uk\]](https://livrepository.liverpool.ac.uk)
- [8. Rhodium - Wikipedia \[en.wikipedia.org\]](https://en.wikipedia.org)
- To cite this document: BenchChem. [Advanced Coordination Dynamics of Rhodium(I) Acetate Complexes]. BenchChem, [2026]. [Online PDF]. Available at: [\[https://www.benchchem.com/product/b8808476/docs#advanced-coordination-dynamics-of-rhodium-i-acetate-complexes\]](https://www.benchchem.com/product/b8808476/docs#advanced-coordination-dynamics-of-rhodium-i-acetate-complexes)

Disclaimer & Data Validity:

The information provided in this document is for Research Use Only (RUO) and is strictly not intended for diagnostic or therapeutic procedures. While BenchChem strives to provide accurate protocols, we make no warranties, express or implied, regarding the fitness of this product for every specific experimental setup.

Technical Support: The protocols provided are for reference purposes. Unsure if this reagent suits your experiment?

Need Industrial/Bulk Grade? [Request Custom Synthesis Quote](#)

BenchChem

Our mission is to be the trusted global source of essential and advanced chemicals, empowering scientists and researchers to drive progress in science and industry.

Contact

Address: 3281 E Guasti Rd

Ontario, CA 91761, United States

Phone: (601) 213-4426

Email: info@benchchem.com

[Contact our Ph.D. Support Team for a compatibility check](#)