

Application Notes: Measuring Cell Proliferation with the FGFR Inhibitor AZD4547

Author: BenchChem Technical Support Team. **Date:** April 2026

Compound of Interest

Compound Name: AZD4547

Cat. No.: B8805471

[Get Quote](#)

Introduction

Fibroblast Growth Factor (FGF) signaling plays a crucial role in various cellular processes, including proliferation, survival, differentiation, and angiogenesis.[1] The pathway is initiated by the binding of FGF ligands to Fibroblast Growth Factor Receptors (FGFRs), a family of four receptor tyrosine kinases (FGFR1-4).[2][3] Aberrant activation of the FGF/FGFR signaling pathway, through gene amplification, mutations, or fusions, is a known driver in the development and progression of numerous cancers.[4][5] This makes the FGFR pathway a key target for anti-cancer therapies.[5]

AZD4547 is a potent and selective, ATP-competitive small molecule inhibitor of FGFR1, 2, and 3.[5][6] It has demonstrated significant anti-proliferative activity in tumor cell lines that exhibit deregulated FGFR signaling.[7] These application notes provide a detailed protocol for assessing the effect of **AZD4547** on cell proliferation in cancer cell lines, intended for researchers, scientists, and drug development professionals.

Mechanism of Action

AZD4547 exerts its anti-tumor effects by binding to the intracellular tyrosine kinase domain of FGFR1, FGFR2, and FGFR3, thereby blocking their activation.[8] This inhibition prevents the

autophosphorylation of the receptors and the subsequent activation of downstream signaling cascades. The primary pathways affected include the Ras-MAPK pathway, which controls cell proliferation and differentiation, the PI3K-Akt pathway, which regulates cell survival, and the PLC γ pathway, which influences cell morphology and migration.[2][9] By blocking these critical pathways, **AZD4547** can induce G1 cell cycle arrest and apoptosis, leading to a reduction in tumor cell proliferation.[7][10]

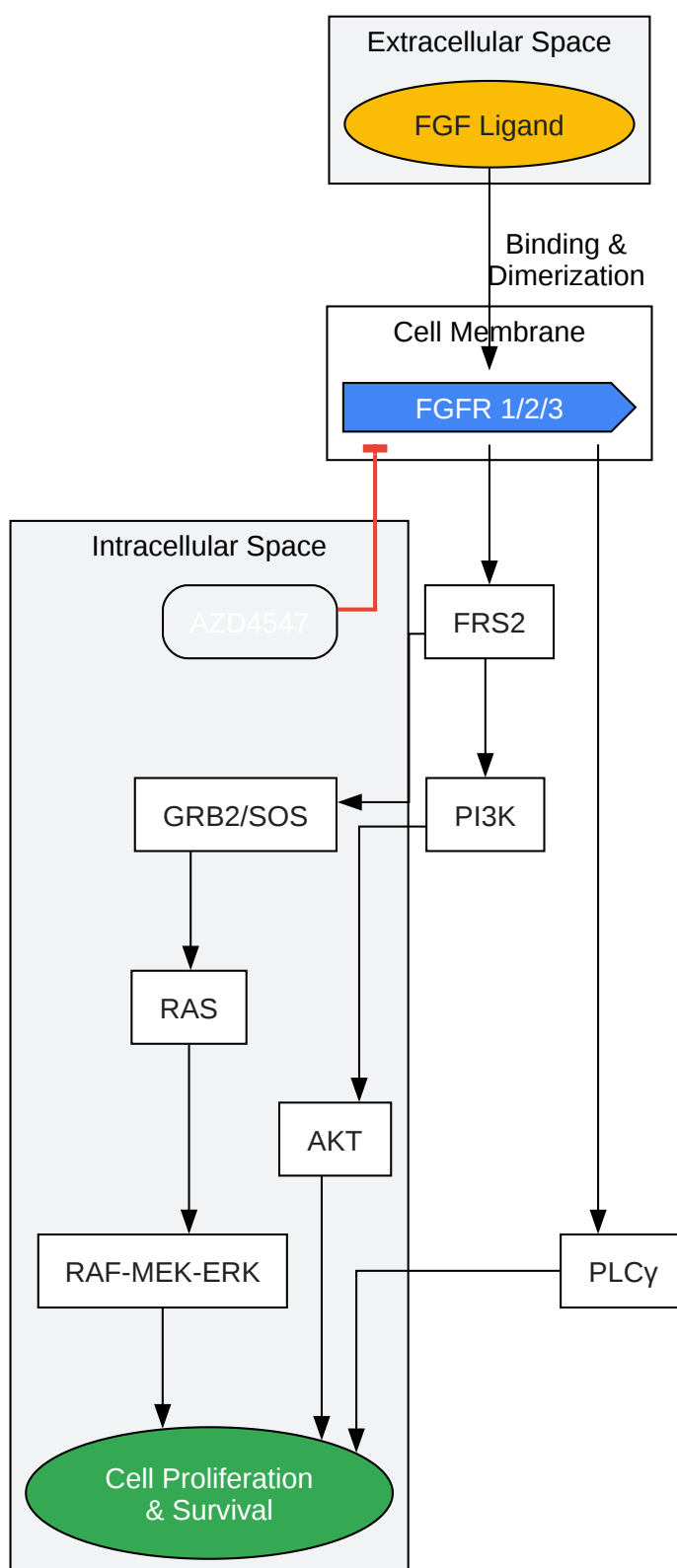

[Click to download full resolution via product page](#)

Caption: FGFR signaling pathway and inhibition by **AZD4547**.

Experimental Protocols

This protocol describes a colorimetric cell proliferation assay (e.g., MTS/XTT or CCK-8) to determine the half-maximal inhibitory concentration (IC₅₀) of **AZD4547**.

Materials and Reagents

- Cancer cell line with known FGFR status (e.g., SNU-16, KMS-11, KG-1a)
- Complete cell culture medium (e.g., RPMI-1640 or DMEM with 10% FBS and 1% Penicillin-Streptomycin)
- **AZD4547** (powder or stock solution in DMSO)
- Dimethyl sulfoxide (DMSO, cell culture grade)
- Phosphate-Buffered Saline (PBS), sterile
- Trypsin-EDTA
- 96-well flat-bottom cell culture plates, sterile
- Cell proliferation assay reagent (e.g., CellTiter 96® AQueous One Solution Reagent (MTS), CCK-8)
- Multichannel pipette
- Microplate reader capable of measuring absorbance at the appropriate wavelength
- Humidified incubator (37°C, 5% CO₂)

Protocol: Cell Proliferation Assay

- Cell Seeding:
 - Culture cells to ~80% confluency.
 - Harvest cells using Trypsin-EDTA, neutralize, and centrifuge to form a pellet.

- Resuspend the cell pellet in complete medium and perform a cell count (e.g., using a hemocytometer or automated cell counter).
- Dilute the cell suspension to the desired seeding density (empirically determined for each cell line, typically 2,000-10,000 cells/well).
- Seed 100 μ L of the cell suspension into each well of a 96-well plate.
- Leave wells on the plate edge filled with sterile PBS or media only to minimize edge effects.
- Incubate the plate for 24 hours to allow cells to attach and resume growth.
- Drug Preparation and Treatment:
 - Prepare a high-concentration stock solution of **AZD4547** in DMSO (e.g., 10 mM). Store at -20°C or -80°C .
 - On the day of treatment, prepare a serial dilution of **AZD4547** in complete culture medium. A common concentration range to test is 0.1 nM to 10 μ M.
 - Ensure the final DMSO concentration in all wells (including the vehicle control) is consistent and low (<0.1%) to avoid solvent toxicity.
 - Remove the medium from the wells and add 100 μ L of the medium containing the appropriate **AZD4547** concentration or vehicle control (medium with DMSO).
 - Include "no-cell" control wells containing medium only for background subtraction.
- Incubation:
 - Return the plate to the incubator and culture for a specified period, typically 72 hours, to allow for an anti-proliferative effect.[7]
- Cell Viability Measurement (MTS Assay Example):
 - After the incubation period, add 20 μ L of the MTS reagent to each well.

- Incubate the plate for 1-4 hours at 37°C. The incubation time should be optimized for the specific cell line.
- Measure the absorbance at 490 nm using a microplate reader.
- Data Analysis:
 - Subtract the average absorbance of the "no-cell" control wells from all other absorbance readings.
 - Calculate the percentage of cell viability for each **AZD4547** concentration relative to the vehicle control (100% viability).
 - Formula: % Viability = (Absorbance of Treated Well / Average Absorbance of Vehicle Control Wells) x 100
 - Plot the percentage of cell viability against the log of the **AZD4547** concentration.
 - Use a non-linear regression analysis (e.g., log(inhibitor) vs. response -- variable slope) with graphing software (e.g., GraphPad Prism) to calculate the IC50 value.

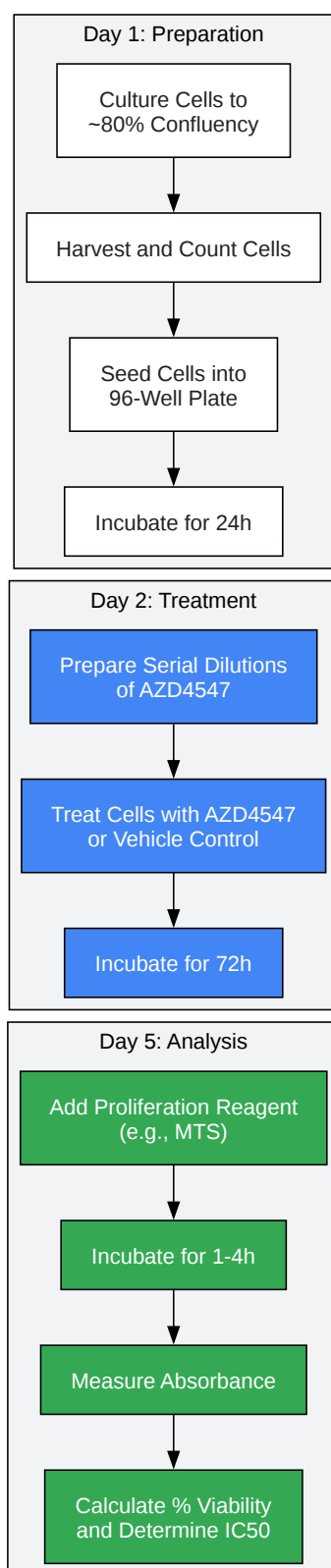

[Click to download full resolution via product page](#)

Caption: Experimental workflow for the cell proliferation assay.

Data Presentation: In Vitro Activity of AZD4547

The anti-proliferative activity of **AZD4547** has been evaluated across a range of cancer cell lines with known FGFR alterations. The IC50 and GI50 values from several studies are summarized below.

Cell Line	Cancer Type	FGFR Alteration	Assay Type	Endpoint (nM)	Reference
KG-1a	Acute Myelogenous Leukemia	FGFR1 Overexpression	Proliferation	IC50: 18	[7]
Sum52-PE	Breast Cancer	FGFR Amplification	Proliferation	IC50: 281	[7]
KMS-11	Multiple Myeloma	FGFR3 Translocation	Proliferation	IC50: 28	[7]
Baf3 (TPR-FGFR1)	Pro-B Cell Line (Engineered)	TPR-FGFR1 Fusion	Proliferation	IC50: 8.5	[11]
KM12(Luc)	Colorectal Cancer	TPM3-NTRK1 Fusion*	Proliferation	GI50: 100	[10]
SNU-16	Gastric Cancer	FGFR2 Amplification	IP-One	IC50: 6.2	[12]
KG-1	Acute Myelogenous Leukemia	FGFR1 Overexpression	IP-One	IC50: 2.0	[12]
KMS-11	Multiple Myeloma	FGFR3 Translocation	IP-One	IC50: 4.7	[12]

*Note: **AZD4547** also shows inhibitory activity against TRK kinases, explaining its effect in the KM12(Luc) cell line.[10]

Conclusion

AZD4547 is a potent inhibitor of the FGFR signaling pathway, effectively reducing cell proliferation in cancer models with aberrant FGFR activity. The provided protocol offers a standardized method for assessing the anti-proliferative effects of **AZD4547** in vitro. Accurate determination of IC50 values is critical for preclinical evaluation and for understanding the compound's therapeutic potential in specific cancer contexts. These notes serve as a comprehensive guide for researchers investigating **AZD4547** and its role in cancer therapy.

Need Custom Synthesis?

BenchChem offers custom synthesis for rare earth carbides and specific isotopic labeling.

Email: info@benchchem.com or [Request Quote Online](#).

References

- [1. Characterization of FGFR signaling pathway as therapeutic targets for sarcoma patients | Cancer Biology & Medicine \[cancerbiomed.org\]](#)
- [2. Understanding FGF Signaling: A Key Pathway in Development and Disease | Proteintech Group \[ptglab.com\]](#)
- [3. The Fibroblast Growth Factor signaling pathway - PMC \[pmc.ncbi.nlm.nih.gov\]](#)
- [4. The FGFR Family Inhibitor AZD4547 Exerts an Antitumor Effect in Ovarian Cancer Cells \[mdpi.com\]](#)
- [5. resources.revvity.com \[resources.revvity.com\]](#)
- [6. Phase II Study of AZD4547 in Patients With Tumors Harboring Aberrations in the FGFR Pathway: Results From the NCI-MATCH Trial \(EAY131\) Subprotocol W - PMC \[pmc.ncbi.nlm.nih.gov\]](#)
- [7. selleckchem.com \[selleckchem.com\]](#)
- [8. researchgate.net \[researchgate.net\]](#)
- [9. researchgate.net \[researchgate.net\]](#)
- [10. Anti-Tumor Activity of AZD4547 Against NTRK1 Fusion Positive Cancer Cells Through Inhibition of NTRKs - PMC \[pmc.ncbi.nlm.nih.gov\]](#)

- 11. Activity of fibroblast growth factor receptor inhibitors TKI258, ponatinib and AZD4547 against TPR-FGFR1 fusion - PMC [pmc.ncbi.nlm.nih.gov]
- 12. resources.revvity.com [resources.revvity.com]
- To cite this document: BenchChem. [Application Notes: Measuring Cell Proliferation with the FGFR Inhibitor AZD4547]. BenchChem, [2026]. [Online PDF]. Available at: [https://www.benchchem.com/product/b8805471/docs#application-notes-measuring-cell-proliferation-with-the-fgfr-inhibitor-azd4547]

Disclaimer & Data Validity:

The information provided in this document is for Research Use Only (RUO) and is strictly not intended for diagnostic or therapeutic procedures. While BenchChem strives to provide accurate protocols, we make no warranties, express or implied, regarding the fitness of this product for every specific experimental setup.

Technical Support: The protocols provided are for reference purposes. Unsure if this reagent suits your experiment?

Need Industrial/Bulk Grade? [Request Custom Synthesis Quote](#)

BenchChem

Our mission is to be the trusted global source of essential and advanced chemicals, empowering scientists and researchers to drive progress in science and industry.

Contact

Address: 3281 E Guasti Rd
Ontario, CA 91761, United States
Phone: (601) 213-4426
Email: info@benchchem.com

[Contact our Ph.D. Support Team for a compatibility check](#)

