

AZD4547: A Technical Guide to Downstream Signaling Pathway Modulation

Author: BenchChem Technical Support Team. **Date:** April 2026

Compound of Interest

Compound Name: AZD4547

Cat. No.: B8805471

[Get Quote](#)

For Researchers, Scientists, and Drug Development Professionals

Introduction

AZD4547 is a potent and selective, orally bioavailable inhibitor of the fibroblast growth factor receptor (FGFR) tyrosine kinases, primarily targeting FGFR1, FGFR2, and FGFR3.[1][2] Dysregulation of the FGF/FGFR signaling axis is a key driver in various malignancies, making it a critical target for therapeutic intervention. **AZD4547** has demonstrated significant anti-tumor activity in preclinical models with deregulated FGFR signaling.[2] This technical guide provides an in-depth overview of the downstream signaling pathways affected by **AZD4547**, supported by quantitative data, detailed experimental methodologies, and visual representations of the molecular interactions. Additionally, this guide will shed light on the known mechanisms of resistance to **AZD4547**. The compound has also been found to exhibit inhibitory effects on Tropomyosin receptor kinases (TRKA, TRKB, and TRKC).[3]

Core Mechanism of Action

AZD4547 exerts its therapeutic effect by competitively binding to the ATP-binding pocket of the FGFR kinase domain, thereby inhibiting its autophosphorylation and subsequent activation of

downstream signaling cascades. This blockade of FGFR signaling leads to the inhibition of cell proliferation, survival, migration, and angiogenesis in FGFR-dependent tumors.

Quantitative Analysis of AZD4547 Potency

The inhibitory activity of **AZD4547** has been quantified across various kinase assays and cell-based proliferation assays. The following tables summarize the key potency data.

Kinase Target	IC50 (nM)	Source
FGFR1	0.2	[1][4]
FGFR2	2.5	[1][4]
FGFR3	1.8	[1][4]
FGFR4	165	[4]
VEGFR2 (KDR)	24	[4]
TRKA	18.7	[3]
TRKB	22.6	[3]
TRKC	2.9	[3]

Table 1: In vitro kinase inhibitory activity of **AZD4547**.

Cell Line	Cancer Type	GI50 (nM)	Source
KM12(Luc)	Colon Cancer (TPM3-NTRK1 fusion)	100	[3]
KG1a	Acute Myeloid Leukemia (FGFR1 fusion)	18-281	[4]
Sum52-PE	Breast Cancer (FGFR amplified)	18-281	[4]
KMS11	Multiple Myeloma (FGFR3 mutation)	18-281	[4]

Table 2: Anti-proliferative activity of **AZD4547** in various cancer cell lines.

Downstream Signaling Pathways Modulated by **AZD4547**

AZD4547-mediated inhibition of FGFRs leads to the modulation of several critical downstream signaling pathways.

RAS-MAPK Pathway

The RAS-MAPK pathway is a central signaling cascade that regulates cell growth, proliferation, and differentiation. Upon FGFR activation, the docking protein FRS2 is phosphorylated, leading to the recruitment of GRB2 and SOS, which in turn activates RAS. This initiates a phosphorylation cascade through RAF, MEK, and finally ERK. **AZD4547** effectively blocks this pathway by preventing the initial FGFR-mediated phosphorylation of FRS2.[5] This results in a dose-dependent decrease in the phosphorylation of MEK1/2 and ERK1/2.[3] Studies have shown that a concentration of 0.1 μM **AZD4547** can completely inhibit the phosphorylation of MEK1/2 and ERK.[3] The inhibition of this pathway is further confirmed by the downregulation of MAPK target genes such as DUSP6, CCND1, and ETV1.[3][6]

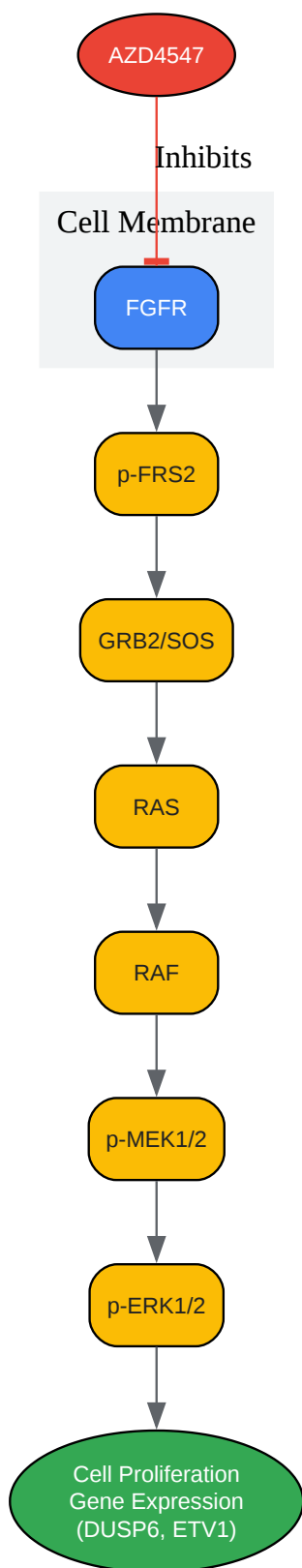

[Click to download full resolution via product page](#)

Figure 1: Inhibition of the RAS-MAPK pathway by **AZD4547**.

PI3K/AKT Pathway

The PI3K/AKT pathway is another crucial signaling route downstream of FGFR that promotes cell survival and proliferation. FGFR activation leads to the recruitment and activation of PI3K, which then phosphorylates PIP2 to PIP3. PIP3 acts as a docking site for AKT and PDK1, leading to AKT phosphorylation and activation. Activated AKT then phosphorylates a variety of downstream targets, including the mTOR pathway effector S6 ribosomal protein. **AZD4547** treatment has been shown to decrease the phosphorylation of AKT and S6.^{[7][8]} However, the impact on the PI3K/AKT pathway can be cell-line dependent, with some studies indicating more consistent modulation in FGFR2-deregulated cell lines.^{[4][9]}

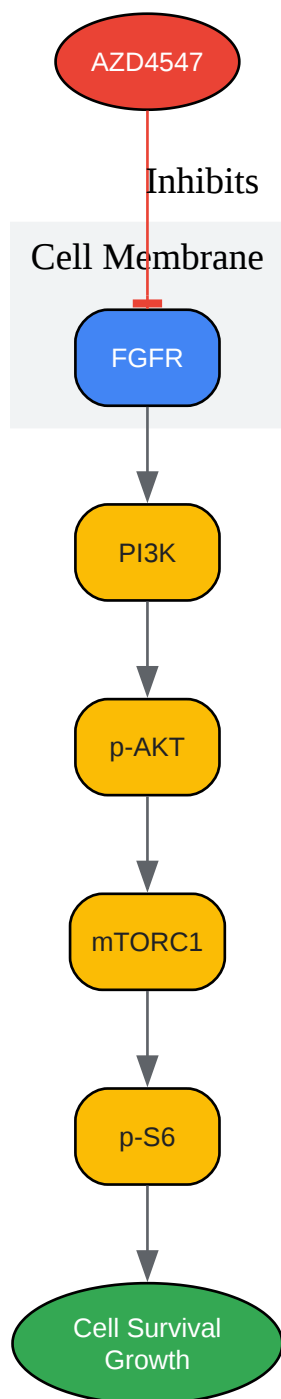

[Click to download full resolution via product page](#)

Figure 2: Attenuation of the PI3K/AKT pathway by **AZD4547**.

PLC γ Pathway

In the context of TRK inhibition, **AZD4547** has been shown to block the phosphorylation of Phospholipase C-gamma (PLC γ).^[3] Activated PLC γ hydrolyzes PIP2 into inositol triphosphate (IP3) and diacylglycerol (DAG), which leads to calcium mobilization and activation of Protein Kinase C (PKC), respectively, influencing various cellular processes.

JAK/STAT Pathway

The JAK/STAT pathway is also implicated in the response to **AZD4547**.^{[7][10]} Interestingly, while **AZD4547** generally leads to a decrease in the phosphorylation of pro-survival signaling proteins, it has been observed to cause an increase in the phosphorylation of STAT3.^{[7][10]} This activation of STAT3 may represent a feedback mechanism or a potential route for acquired resistance.

Mechanisms of Resistance to AZD4547

The development of resistance is a significant challenge in targeted cancer therapy. Several mechanisms of resistance to **AZD4547** have been identified.

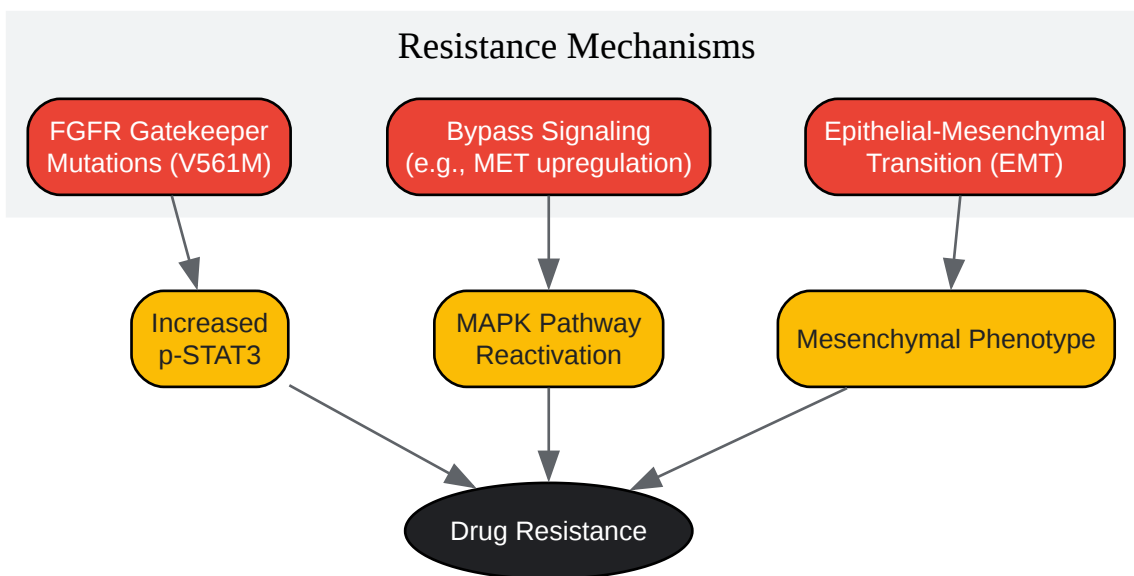

[Click to download full resolution via product page](#)

Figure 3: Overview of resistance mechanisms to **AZD4547**.

- Gatekeeper Mutations: The most well-characterized resistance mechanism is the acquisition of gatekeeper mutations in the FGFR kinase domain, such as V561M in FGFR1 and V555M

in FGFR3.[11][12][13] While **AZD4547** can still bind to the V561M mutant, resistance is driven by a significant increase in the downstream activation of STAT3.[11]

- **Bypass Signaling:** Cancer cells can develop resistance by upregulating alternative signaling pathways. For instance, increased expression of the MET receptor tyrosine kinase can reactivate the MAPK pathway, thereby bypassing the FGFR blockade.[12]
- **Epithelial-Mesenchymal Transition (EMT):** Prolonged exposure to **AZD4547** can induce a shift towards a mesenchymal phenotype, a process known as EMT. This is characterized by changes in cell morphology and the expression of specific markers, which is associated with increased motility and drug resistance.[12]

Experimental Protocols

This section outlines the general methodologies for key experiments used to study the effects of **AZD4547** on downstream signaling pathways.

Western Blotting for Phosphoprotein Analysis



[Click to download full resolution via product page](#)

Figure 4: General workflow for Western blot analysis.

- **Cell Culture and Treatment:** Plate cells at an appropriate density and allow them to adhere overnight. Treat cells with various concentrations of **AZD4547** or vehicle control (e.g., DMSO) for the desired duration (e.g., 2 hours for phosphorylation studies).
- **Cell Lysis:** Wash cells with ice-cold PBS and lyse with RIPA buffer supplemented with protease and phosphatase inhibitors.
- **Protein Quantification:** Determine the protein concentration of the lysates using a BCA or Bradford assay.

- SDS-PAGE: Denature protein lysates in Laemmli buffer and separate them on a polyacrylamide gel by electrophoresis.
- Protein Transfer: Transfer the separated proteins from the gel to a nitrocellulose or PVDF membrane.
- Blocking: Block the membrane with 5% non-fat milk or bovine serum albumin (BSA) in Tris-buffered saline with Tween 20 (TBST) for 1 hour at room temperature to prevent non-specific antibody binding.
- Antibody Incubation: Incubate the membrane with primary antibodies against the proteins of interest (e.g., phospho-FGFR, total FGFR, phospho-ERK, total ERK, phospho-AKT, total AKT) overnight at 4°C.
- Washing and Secondary Antibody Incubation: Wash the membrane with TBST and then incubate with a horseradish peroxidase (HRP)-conjugated secondary antibody for 1 hour at room temperature.
- Detection: After further washing, detect the protein bands using an enhanced chemiluminescence (ECL) substrate and imaging system.
- Analysis: Quantify band intensities using densitometry software and normalize to a loading control (e.g., β -actin or GAPDH).

In Vitro Kinase Assay

- Assay Setup: In a microplate, combine recombinant FGFR enzyme, a suitable substrate (e.g., a synthetic peptide), and ATP.
- Inhibitor Addition: Add serial dilutions of **AZD4547** to the wells.
- Kinase Reaction: Initiate the kinase reaction by adding ATP and incubate at 30°C for a specified time.
- Detection: Stop the reaction and measure the amount of phosphorylated substrate. This can be done using various methods, such as radioactivity (^{32}P -ATP), fluorescence, or luminescence-based assays that detect the remaining ATP.

- Data Analysis: Plot the percentage of kinase inhibition against the log concentration of **AZD4547** to determine the IC50 value.

Cell Viability (MTS/MTT) Assay

- Cell Seeding: Seed cells in a 96-well plate and allow them to attach overnight.
- Compound Treatment: Treat the cells with a range of concentrations of **AZD4547** for a specified period (e.g., 72 hours).
- Reagent Addition: Add MTS or MTT reagent to each well and incubate for 1-4 hours at 37°C. Live cells will convert the reagent into a colored formazan product.
- Solubilization (for MTT): If using MTT, add a solubilizing agent (e.g., DMSO) to dissolve the formazan crystals.
- Absorbance Measurement: Measure the absorbance at the appropriate wavelength using a microplate reader.
- Data Analysis: Calculate the percentage of cell viability relative to the vehicle-treated control cells and plot against the log concentration of **AZD4547** to determine the GI50 value.

Quantitative Real-Time PCR (qRT-PCR) for Gene Expression Analysis

- Cell Treatment and RNA Extraction: Treat cells with **AZD4547** as described above. Extract total RNA using a suitable kit.
- cDNA Synthesis: Synthesize complementary DNA (cDNA) from the extracted RNA using a reverse transcriptase enzyme.
- qRT-PCR: Perform qRT-PCR using the synthesized cDNA, gene-specific primers (e.g., for DUSP6, ETV1), and a fluorescent dye (e.g., SYBR Green).
- Data Analysis: Determine the relative expression of the target genes by normalizing to a housekeeping gene (e.g., GAPDH) using the $\Delta\Delta C_t$ method.

Conclusion

AZD4547 is a potent inhibitor of FGFR1, 2, and 3, with demonstrated activity against TRK kinases as well. Its primary mechanism of action involves the blockade of key downstream signaling pathways, most notably the RAS-MAPK and PI3K/AKT cascades, leading to reduced tumor cell proliferation and survival. Understanding the intricacies of these signaling networks, along with the mechanisms of resistance, is paramount for the strategic clinical development of **AZD4547** and the design of effective combination therapies. The experimental protocols outlined in this guide provide a framework for researchers to further investigate the molecular effects of this and other FGFR inhibitors.

Need Custom Synthesis?

BenchChem offers custom synthesis for rare earth carbides and specific isotopic labeling.

Email: info@benchchem.com or [Request Quote Online](#).

References

- [1. Anti-Tumor Activity of AZD4547 Against NTRK1 Fusion Positive Cancer Cells Through Inhibition of NTRKs - PMC \[pmc.ncbi.nlm.nih.gov\]](#)
- [2. aacrjournals.org \[aacrjournals.org\]](#)
- [3. Dual specificity phosphatase 6 \(DUSP6\) is an ETS-regulated negative feedback mediator of oncogenic ERK signaling in lung cancer cells - PMC \[pmc.ncbi.nlm.nih.gov\]](#)
- [4. Mechanisms of Efficacy of the FGFR1-3 Inhibitor AZD4547 in Pediatric Solid Tumor Models - PubMed \[pubmed.ncbi.nlm.nih.gov\]](#)
- [5. resources.revvity.com \[resources.revvity.com\]](#)
- [6. Cell Viability Assays - Assay Guidance Manual - NCBI Bookshelf \[ncbi.nlm.nih.gov\]](#)
- [7. selleckchem.com \[selleckchem.com\]](#)
- [8. revvity.com \[revvity.com\]](#)
- [9. Western Blot Procedure | Cell Signaling Technology \[cellsignal.com\]](#)
- [10. researchgate.net \[researchgate.net\]](#)
- [11. mdpi.com \[mdpi.com\]](#)

- [12. Repurposing of the FGFR inhibitor AZD4547 as a potent inhibitor of necroptosis by selectively targeting RIPK1 - PMC \[pmc.ncbi.nlm.nih.gov\]](#)
- [13. researchgate.net \[researchgate.net\]](#)
- To cite this document: BenchChem. [AZD4547: A Technical Guide to Downstream Signaling Pathway Modulation]. BenchChem, [2026]. [Online PDF]. Available at: [\[https://www.benchchem.com/product/b8805471/docs#azd4547-a-technical-guide-to-downstream-signaling-pathway-modulation\]](https://www.benchchem.com/product/b8805471/docs#azd4547-a-technical-guide-to-downstream-signaling-pathway-modulation)

Disclaimer & Data Validity:

The information provided in this document is for Research Use Only (RUO) and is strictly not intended for diagnostic or therapeutic procedures. While BenchChem strives to provide accurate protocols, we make no warranties, express or implied, regarding the fitness of this product for every specific experimental setup.

Technical Support: The protocols provided are for reference purposes. Unsure if this reagent suits your experiment?

Need Industrial/Bulk Grade? [Request Custom Synthesis Quote](#)

BenchChem

Our mission is to be the trusted global source of essential and advanced chemicals, empowering scientists and researchers to drive progress in science and industry.

Contact

Address: 3281 E Guasti Rd
Ontario, CA 91761, United States
Phone: (601) 213-4426
Email: info@benchchem.com

[Contact our Ph.D. Support Team for a compatibility check](#)

