

Flow Chemistry Protocols for Reactions Involving Methyl Azide: Application Notes

Author: BenchChem Technical Support Team. **Date:** April 2026

Compound of Interest

Compound Name: Methyl azide

CAS No.: 624-90-8

Cat. No.: B8796563

[Get Quote](#)

For Researchers, Scientists, and Drug Development Professionals

Introduction

Methyl azide (CH_3N_3) is a high-energy, potentially explosive molecule that serves as a valuable reagent in organic synthesis, particularly in the formation of nitrogen-containing heterocycles.[1] Its hazardous nature, however, often limits its use in traditional batch chemistry. Continuous flow chemistry offers a significantly safer and more efficient alternative for handling such hazardous reagents.[2][3] By generating and consuming **methyl azide** in situ within a sealed and controlled microreactor environment, the risks associated with its accumulation, storage, and handling are largely mitigated.[4][5] This document provides detailed application notes and protocols for conducting chemical reactions involving **methyl azide** using flow chemistry, enabling researchers to leverage the synthetic utility of this reagent with enhanced safety and control.

The primary advantages of employing flow chemistry for **methyl azide** reactions include:

- Enhanced Safety: In-situ generation and immediate consumption of **methyl azide** prevent the accumulation of explosive concentrations.[2][4]
- Precise Reaction Control: Microreactors provide superior control over reaction parameters such as temperature, pressure, and residence time, leading to higher yields and selectivities. [6]
- Rapid Reaction Screening and Optimization: The small scale and automated nature of flow systems facilitate rapid screening of reaction conditions.
- Scalability: Flow chemistry protocols can often be scaled up more easily and safely than batch processes.[7]

This document will focus on the in-situ generation of **methyl azide** and its subsequent use in [3+2] cycloaddition reactions to synthesize important heterocyclic scaffolds like tetrazoles.

Core Concepts and Workflow

The general workflow for reactions involving in-situ generated **methyl azide** in a continuous flow setup involves two main stages:

- Generation of **Methyl Azide**: A solution of a suitable precursor, such as sodium azide, is reacted with a methylating agent (e.g., dimethyl sulfate) in a microreactor to generate a stream of **methyl azide** solution.
- Reaction with a Substrate: The **methyl azide** stream is then merged with a stream containing the substrate (e.g., a nitrile or an alkyne) in a second microreactor, where the desired reaction takes place.

This "generate-and-react" approach is a cornerstone of safe hazardous chemistry in flow.[4]

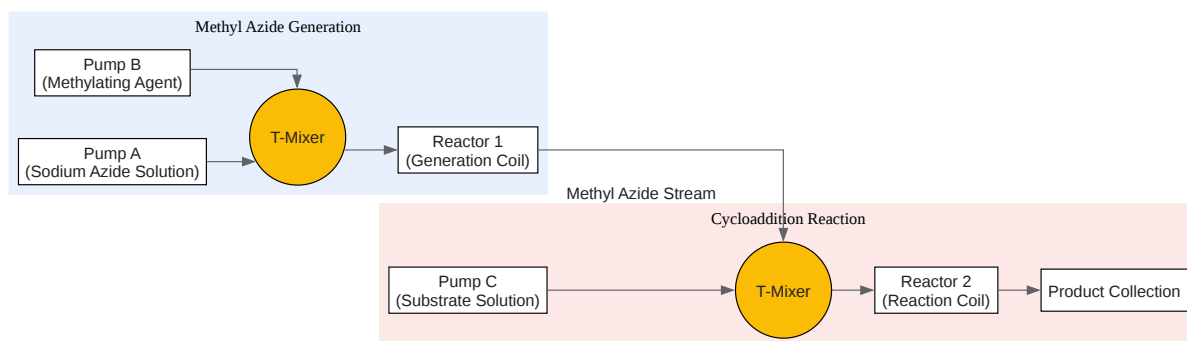

[Click to download full resolution via product page](#)

General workflow for in-situ generation and reaction of **methyl azide** in a flow system.

Application Note 1: Continuous Flow Synthesis of 5-Substituted-1H-tetrazoles

Tetrazoles are important scaffolds in medicinal chemistry, often serving as bioisosteres for carboxylic acids.[8] The reaction of nitriles with an azide source is a common method for their synthesis. Flow chemistry provides a safe and efficient means to perform this transformation at elevated temperatures, significantly accelerating the reaction rate.[7][8]

Experimental Protocol: Synthesis of 5-Phenyl-1H-tetrazole

This protocol is adapted from a general method for the continuous-flow synthesis of 5-substituted tetrazoles.[8]

Reagent Preparation:

- Solution A (Azide): Dissolve sodium azide (NaN_3 , 1.05 equivalents) in deionized water.
- Solution B (Nitrile): Dissolve the desired nitrile (e.g., benzonitrile, 1 equivalent) in a suitable solvent such as N-methyl-2-pyrrolidone (NMP).

Flow System Setup:

- Two syringe pumps are used to introduce the reagent solutions into the flow system.
- The outlets of the pumps are connected to a T-mixer.
- The T-mixer is connected to a stainless steel or PFA tubing reactor coil. The reactor length and internal diameter will determine the residence time.
- A back-pressure regulator is installed at the outlet of the reactor to maintain a constant pressure and prevent solvent boiling at elevated temperatures.
- The product stream is collected in a suitable vessel. For safety, an in-line quenching solution (e.g., aqueous sodium nitrite) can be introduced before collection to destroy any unreacted azide.[7]

Reaction Parameters:

Parameter	Value
Reagents	
Benzonitrile Concentration	~0.4 M in NMP/Water
Sodium Azide	1.05 equivalents
Flow Parameters	
Flow Rate (Pump A)	To be optimized for desired residence time
Flow Rate (Pump B)	To be optimized for desired residence time
Residence Time	~10-20 minutes
Temperature	190 °C
Pressure	Maintained above the solvent's boiling point

Procedure:

- Prime the pumps and the reactor with the respective solvent.
- Set the reactor temperature to 190 °C.
- Start pumping Solution A and Solution B at the calculated flow rates to achieve the desired residence time.
- Allow the system to reach a steady state before collecting the product.
- After the reaction is complete, flush the system with fresh solvent.
- The collected product solution is then subjected to standard work-up and purification procedures.

Quantitative Data for Tetrazole Synthesis

The following table summarizes representative yields for the synthesis of various 5-substituted-1H-tetrazoles using a continuous flow methodology.

Nitrile Substrate	Product	Yield (%)	Reference
Benzonitrile	5-Phenyl-1H-tetrazole	>95	[8]
4-Methoxybenzonitrile	5-(4-Methoxyphenyl)-1H-tetrazole	>95	[8]
2-Chlorobenzonitrile	5-(2-Chlorophenyl)-1H-tetrazole	>95	[8]
Valeronitrile	5-Butyl-1H-tetrazole	>95	[8]

Application Note 2: Copper-Catalyzed Azide-Alkyne Cycloaddition (CuAAC) in Flow

The Copper(I)-catalyzed Azide-Alkyne Cycloaddition (CuAAC) is a cornerstone of "click chemistry" and a powerful tool for the synthesis of 1,4-disubstituted-1,2,3-triazoles.[9][10] Performing this reaction in a continuous flow system using in-situ generated azides offers significant safety and efficiency advantages.[9]

Experimental Protocol: Synthesis of 1-Methyl-4-phenyl-1H-1,2,3-triazole

This protocol is a representative example based on general principles of CuAAC reactions in flow.

Reagent Preparation:

- Solution A (**Methyl Azide** Generation): A solution of sodium azide in a suitable solvent (e.g., DMSO or a water/organic mixture).
- Solution B (Methylating Agent): A solution of a methylating agent (e.g., dimethyl sulfate) in the same solvent.
- Solution C (Alkyne): A solution of the alkyne (e.g., phenylacetylene) in the reaction solvent.

Flow System Setup:

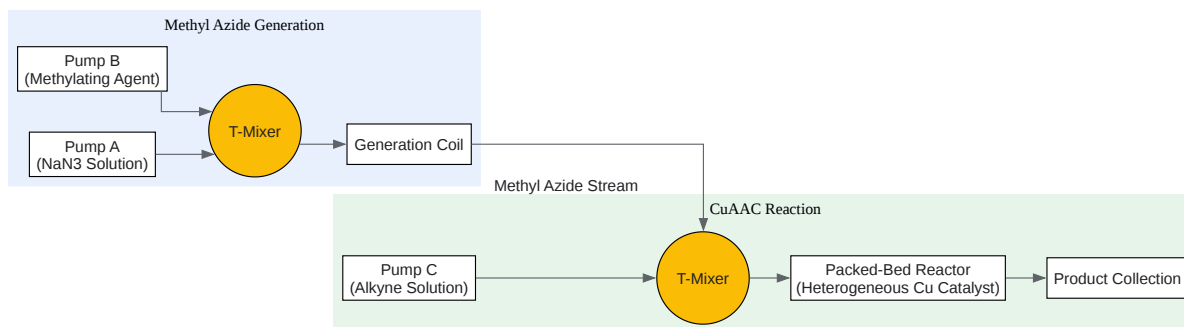

[Click to download full resolution via product page](#)

Workflow for a continuous flow CuAAC reaction with in-situ **methyl azide** generation.

- The setup for **methyl azide** generation is similar to the previous application note.
- The output from the azide generation reactor is then mixed with the alkyne solution (Solution C) at a second T-mixer.
- The combined stream is passed through a heated reactor column packed with a heterogeneous copper catalyst (e.g., copper on charcoal or copper tubing).[9]
- A back-pressure regulator is used to maintain the system pressure.
- The product stream is collected for analysis and purification.

Reaction Parameters:

Parameter	Value
Reagents	
Azide Concentration (in-situ)	~0.1 M
Alkyne Concentration	~0.13 M
Catalyst	Copper-on-charcoal
Flow Parameters	
Residence Time (Azide Generation)	To be optimized
Residence Time (CuAAC)	~2-5 minutes
Temperature	80-120 °C
Solvent	Dichloromethane (DCM), DMSO, or others

Procedure:

- Pack a column with the copper catalyst and integrate it into the flow path.
- Prime the pumps and the entire system with the reaction solvent.
- Set the desired temperatures for the generation and reaction coils.
- Initiate the flow of all three reagent solutions at the calculated rates.
- Allow the system to stabilize before collecting the product.
- Upon completion, flush the system with solvent.

Quantitative Data for CuAAC Reactions

The following table presents data for the synthesis of various 1,2,3-triazoles using a heterogeneous copper catalyst in a continuous flow system.

Azide	Alkyne	Product	Yield (%)	Reference
Phenyl Azide	Phenylacetylene	1,4-Diphenyl-1H-1,2,3-triazole	98	[9]
Benzyl Azide	Phenylacetylene	1-Benzyl-4-phenyl-1H-1,2,3-triazole	99	[9]
4-Nitrophenyl Azide	Phenylacetylene	1-(4-Nitrophenyl)-4-phenyl-1H-1,2,3-triazole	97	[9]
2,6-Difluorobenzyl Azide	Propiolamide	Rufinamide	96	[9]

Safety Considerations

While flow chemistry significantly enhances the safety of working with **methyl azide**, it is crucial to adhere to strict safety protocols:

- **System Integrity:** Ensure all connections in the flow setup are secure and leak-proof, especially when operating at elevated pressures.
- **Material Compatibility:** Use materials (tubing, reactors, fittings) that are compatible with all reagents and solvents.
- **Ventilation:** Operate the flow system in a well-ventilated fume hood.
- **Precursor Handling:** Sodium azide is highly toxic. Handle with appropriate personal protective equipment (PPE).
- **Quenching:** Always have a quenching agent (e.g., sodium nitrite solution) readily available to neutralize any potential spills or unreacted azide in the final product stream.[7]
- **Avoid Acidic Conditions:** Do not mix azides with acids, as this can generate the highly toxic and explosive hydrazoic acid.

- Avoid Heavy Metals: Prevent contact of sodium azide with heavy metals (e.g., lead, copper in plumbing) to avoid the formation of explosive heavy metal azides.

Conclusion

Continuous flow chemistry provides a robust and safe platform for the synthesis and application of **methyl azide**. By generating this hazardous intermediate in situ and immediately consuming it in subsequent reactions, researchers can safely access a wide range of valuable nitrogen-containing heterocyclic compounds. The protocols and data presented in these application notes serve as a starting point for developing and optimizing a variety of chemical transformations involving **methyl azide** in a continuous flow environment.

Need Custom Synthesis?

BenchChem offers custom synthesis for rare earth carbides and specific isotopic labeling.

Email: info@benchchem.com or [Request Quote Online](#).

References

1. pubs.acs.org [pubs.acs.org]
 2. BJOC - Safe and highly efficient adaptation of potentially explosive azide chemistry involved in the synthesis of Tamiflu using continuous-flow technology [beilstein-journals.org]
 3. Safe and highly efficient adaptation of potentially explosive azide chemistry involved in the synthesis of Tamiflu using continuous-flow technology - PMC [[pmc.ncbi.nlm.nih.gov](https://pubmed.ncbi.nlm.nih.gov/)]
 4. benchchem.com [benchchem.com]
 5. innosyn.com [innosyn.com]
 6. d-nb.info [d-nb.info]
 7. Safe and Efficient Tetrazole Synthesis in a Continuous Flow Microreactor [dspace.mit.edu]
 8. files01.core.ac.uk [files01.core.ac.uk]
 9. A practical flow synthesis of 1,2,3-triazoles - PMC [[pmc.ncbi.nlm.nih.gov](https://pubmed.ncbi.nlm.nih.gov/)]
 10. researchgate.net [researchgate.net]
- To cite this document: BenchChem. [Flow Chemistry Protocols for Reactions Involving Methyl Azide: Application Notes]. BenchChem, [2026]. [Online PDF]. Available at:

[<https://www.benchchem.com/product/b8796563/docs#flow-chemistry-protocols-for-reactions-involving-methyl-azide-application-notes>]

Disclaimer & Data Validity:

The information provided in this document is for Research Use Only (RUO) and is strictly not intended for diagnostic or therapeutic procedures. While BenchChem strives to provide accurate protocols, we make no warranties, express or implied, regarding the fitness of this product for every specific experimental setup.

Technical Support: The protocols provided are for reference purposes. Unsure if this reagent suits your experiment?

Need Industrial/Bulk Grade? [Request Custom Synthesis Quote](#)

BenchChem

Our mission is to be the trusted global source of essential and advanced chemicals, empowering scientists and researchers to drive progress in science and industry.

Contact

Address: 3281 E Guasti Rd
Ontario, CA 91761, United States
Phone: (601) 213-4426
Email: info@benchchem.com

[Contact our Ph.D. Support Team for a compatibility check](#)