

Technical Comparison Guide: Mass Spectrometry Fragmentation of Dimethoxyisatoic Anhydride

Author: BenchChem Technical Support Team. **Date:** April 2026

Compound of Interest

Compound Name: 4,6-Dimethoxyisatoic anhydride

Cat. No.: B8794287

[Get Quote](#)

Executive Summary

Dimethoxyisatoic Anhydride (DMIA) (specifically the 4,5-dimethoxy isomer, CAS 20197-92-6) is a critical heterocyclic building block used primarily in the synthesis of bioactive quinazolinones and as a tunable acylating agent in RNA structure probing (SHAPE chemistry).[1][2][3][4]

This guide provides a definitive technical analysis of its mass spectrometry (MS) behavior, contrasting it with standard Isatoic Anhydride (IA) and the high-reactivity N-Methylisatoic Anhydride (NMIA).[2] By understanding the specific fragmentation pathways—principally the characteristic loss of CO₂—researchers can validate product integrity and monitor reaction progress with high specificity.

Part 1: Mechanism of Fragmentation

The mass spectral signature of isatoic anhydrides is dominated by the stability of the benzoxazine dione ring and its subsequent collapse. For DMIA (MW 223.18), the fragmentation follows a predictable, electronically driven pathway.

The Primary Pathway: Decarboxylation

Upon ionization (EI or ESI+), the molecular ion (

or

) undergoes a rapid Retro-Diels-Alder (RDA)-type cleavage, ejecting a neutral carbon dioxide molecule.^[2] This is the diagnostic "fingerprint" of the anhydride functionality.

- Precursor: m/z 223 (Dimethoxyisatoic Anhydride)^{[1][5]}
- Transition: Loss of 44 Da (CO_2)
- Product: m/z 179 (Dimethoxyanthranilic acid radical cation or nitrene-like species)^[2]

Secondary Fragmentation

The resulting m/z 179 ion is highly reactive. It typically stabilizes by ejecting Carbon Monoxide (CO , 28 Da) to contract the ring or by losing methyl radicals (

, 15 Da) from the methoxy substituents.

Fragmentation Pathway Diagram

The following diagram illustrates the stepwise degradation of DMIA under standard collision-induced dissociation (CID) or electron impact conditions.

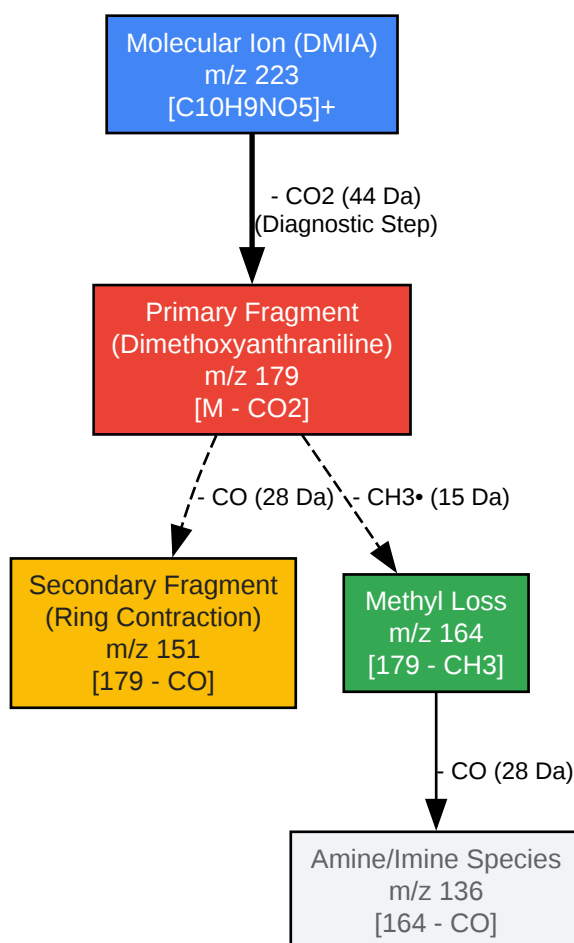

[Click to download full resolution via product page](#)

Figure 1: Proposed fragmentation pathway for 4,5-dimethoxyisatoic anhydride (m/z 223), highlighting the diagnostic loss of CO₂.^[2]

Part 2: Comparative Performance Analysis

In drug discovery and RNA probing, DMIA is often weighed against unsubstituted Isatoic Anhydride (IA) and N-Methyl Isatoic Anhydride (NMIA).^[2] The presence of electron-donating methoxy groups significantly alters both the MS profile and chemical reactivity.^[2]

Mass Spectral Comparison Table

Feature	Dimethoxyisatoic Anhydride (DMIA)	Isatoic Anhydride (IA)	N-Methyl Isatoic Anhydride (NMIA)
Molecular Weight	223.18	163.13	177.16
Base Peak (EI)	m/z 179 (M-CO ₂)	m/z 119 (M-CO ₂)	m/z 133 (M-CO ₂)
Molecular Ion Stability	High (Methoxy stabilization)	Moderate	Moderate
Secondary Loss	-CH ₃ (15 Da) & -CO (28 Da)	-CO (28 Da)	-CO (28 Da)
Diagnostic Shift	+60 Da vs IA (2 x OMe)	Reference	+14 Da vs IA (N-Me)

Electronic Effects on Performance[2]

- DMIA (Electron Rich): The two methoxy groups at positions 4 and 5 are electron-donating.[2] In Mass Spectrometry, this stabilizes the radical cation, often making the molecular ion () more abundant than in nitro-substituted derivatives (like 1M7).
- Reactivity Implication: In synthesis or SHAPE chemistry, this electron density reduces the electrophilicity of the anhydride carbonyl. Consequently, DMIA reacts slower with nucleophiles (amines or RNA 2'-OH) compared to NMIA or 1M7.[2] This makes it a "slow" probe, useful for capturing slower conformational dynamics or avoiding over-modification.[2]

Part 3: Experimental Protocol (Self-Validating)

This protocol ensures accurate identification of DMIA using LC-MS/MS or GC-MS.[2]

Sample Preparation

- Solvent: Dissolve 1 mg of DMIA in Acetonitrile (ACN) or DMSO. Avoid alcohols (Methanol/Ethanol) as they will react with the anhydride to form esters (solvolysis), creating artifacts (M+32 or M+46 peaks).
- Concentration: Dilute to 10 μ M for ESI-MS infusion.

MS Acquisition Parameters (ESI+)

- Ionization: Electrospray Ionization (Positive Mode).
- Capillary Voltage: 3.0 - 3.5 kV.[2]
- Cone Voltage: 20 V (Keep low to preserve the fragile anhydride ring).
- Collision Energy (CID): Stepped 10–30 eV.

Validation Workflow

Use the following logic gate to confirm product identity:

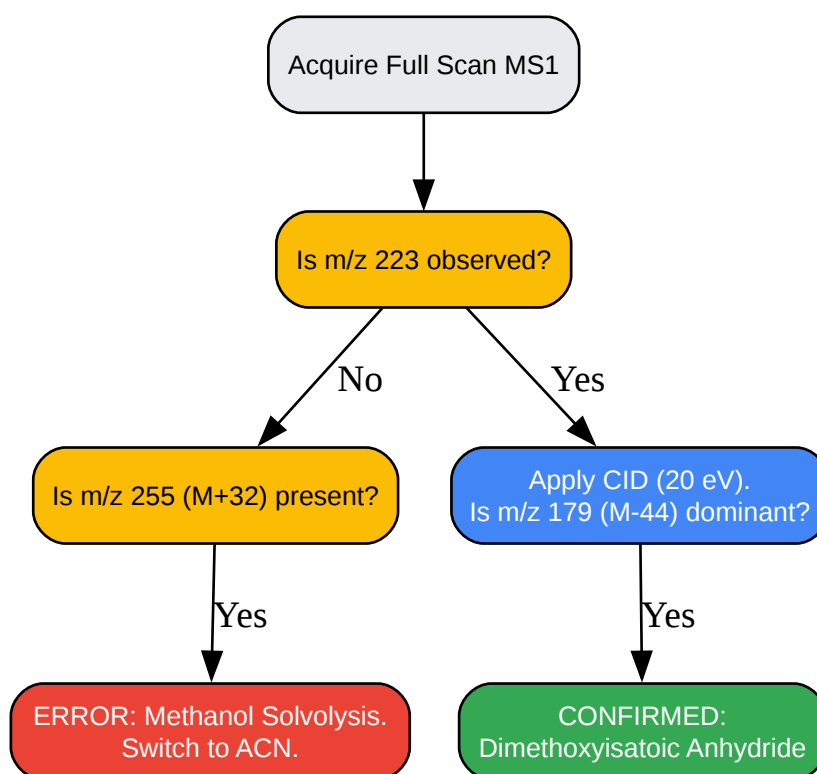

[Click to download full resolution via product page](#)

Figure 2: Decision tree for validating DMIA integrity and ruling out common solvent artifacts.

Part 4: Applications & Causality

Quinazolinone Synthesis Monitoring

DMIA is the precursor for 6,7-dimethoxy-4-quinazolinones (e.g., Prazosin intermediates).[2]

- Process: DMIA reacts with an amine, releasing CO₂ and water.[2]
- MS Monitoring: Monitor the disappearance of m/z 223 and the appearance of the quinazolinone product (). The loss of the m/z 223 peak confirms the ring opening and decarboxylation.

RNA SHAPE Chemistry

While less common than 1M7, DMIA derivatives are used when a less aggressive electrophile is required.[2]

- Mechanism: Acylation of the RNA 2'-OH group.[2]
- Detection: The "adduct" mass on the RNA nucleotide will be +179 Da (the dimethoxyanthraniloyl moiety). This is distinct from the +133 Da adduct of NMIA, allowing for multi-probe experiments where different reagents mark different timescales of folding.

References

- National Institute of Standards and Technology (NIST). Isatoic Anhydride Mass Spectrum (Electron Ionization). NIST Chemistry WebBook, SRD 69.[2][6] [\[Link\]](#)
- PubChem. 4,5-Dimethoxyisatoic Anhydride Compound Summary. National Library of Medicine. [\[Link\]](#)
- Spitale, R. C., et al. (2013).[2] RNA SHAPE analysis in living cells.[2] Nature Chemical Biology.[2] (Discusses Isatoic Anhydride derivatives 1M7 and NMIA). [\[Link\]](#)

Need Custom Synthesis?

BenchChem offers custom synthesis for rare earth carbides and specific isotopic labeling.

Email: info@benchchem.com or [Request Quote Online](#).

Sources

- [1. CAS 20197-92-6: 4,5-Dimethoxyisatoic anhydride \[cymitquimica.com\]](#)
- [2. bocsci.com \[bocsci.com\]](#)
- [3. Dissection of Fragmentation Pathways in Protonated N-acetylhexosamines - PMC \[pmc.ncbi.nlm.nih.gov\]](#)
- [4. Isatoic anhydride - Wikipedia \[en.wikipedia.org\]](#)
- [5. 4,5-DIMETHOXY-ISATOIC ANHYDRIDE synthesis - chemicalbook \[chemicalbook.com\]](#)
- [6. 4-Methoxybenzoic acid anhydride \[webbook.nist.gov\]](#)
- To cite this document: BenchChem. [Technical Comparison Guide: Mass Spectrometry Fragmentation of Dimethoxyisatoic Anhydride]. BenchChem, [2026]. [Online PDF]. Available at: [<https://www.benchchem.com/product/b8794287/docs#technical-comparison-guide-mass-spectrometry-fragmentation-of-dimethoxyisatoic-anhydride>]

Disclaimer & Data Validity:

The information provided in this document is for Research Use Only (RUO) and is strictly not intended for diagnostic or therapeutic procedures. While BenchChem strives to provide accurate protocols, we make no warranties, express or implied, regarding the fitness of this product for every specific experimental setup.

Technical Support: The protocols provided are for reference purposes. Unsure if this reagent suits your experiment?

Need Industrial/Bulk Grade? [Request Custom Synthesis Quote](#)

BenchChem

Our mission is to be the trusted global source of essential and advanced chemicals, empowering scientists and researchers to drive progress in science and industry.

Contact

Address: 3281 E Guasti Rd

Ontario, CA 91761, United States

Phone: (601) 213-4426

Email: info@benchchem.com

Contact our Ph.D. Support Team for a compatibility check