

In Vitro Metabolic Stability Guide: Fluorinated vs. Non-Fluorinated Piperazines

Author: BenchChem Technical Support Team. **Date:** May 2026

Compound of Interest

Compound Name: 2-(Difluoromethyl)piperazine

Cat. No.: B8785294

[Get Quote](#)

Executive Summary

The piperazine ring is a privileged scaffold in medicinal chemistry, ubiquitous in antidepressants, antihistamines, and antipsychotics. However, it is frequently a "metabolic soft spot," susceptible to rapid oxidative clearance via Cytochrome P450 (CYP) enzymes. This guide analyzes the strategic incorporation of fluorine—specifically mono-fluorination, gem-difluorination, and trifluoromethylation—to enhance the metabolic stability of piperazine derivatives. We provide a direct performance comparison, mechanistic rationale, and a validated experimental protocol for assessing intrinsic clearance (

) in liver microsomes.

Mechanistic Rationale: The "Fluorine Effect"

To interpret stability data effectively, one must understand why fluorination mitigates metabolism. It is not merely about bond strength; it is about electronic deactivation and steric protection.

A. Blocking Metabolic Soft Spots

Unsubstituted piperazines undergo rapid N-dealkylation and alpha-carbon hydroxylation. CYP450 enzymes typically abstract a hydrogen atom from the carbon

to the nitrogen (the most electron-rich site).

- Mechanism: The lone pair on the nitrogen stabilizes the resulting radical cation.
- Fluorine Intervention: Replacing -hydrogens with fluorine removes the abstractable proton. Furthermore, the C-F bond () is significantly stronger than the C-H bond (), rendering direct abstraction energetically unfavorable.

B. Modulation of

and Lipophilicity

- Basicity (): The strong electronegativity of fluorine pulls electron density away from the piperazine nitrogens, lowering their basicity (). This reduces the formation of ammonium species at physiological pH, which can alter binding affinity to the heme iron of CYP enzymes.
- Lipophilicity (): While mono-fluorination often lowers slightly due to polarity, poly-fluorination (e.g.,) increases lipophilicity. However, the primary stability gain comes from preventing the formation of the unstable carbinolamine intermediate.

C. Visualizing the Metabolic Blockade

The following diagram illustrates the oxidative pathway of a standard piperazine versus the blockade provided by fluorination.

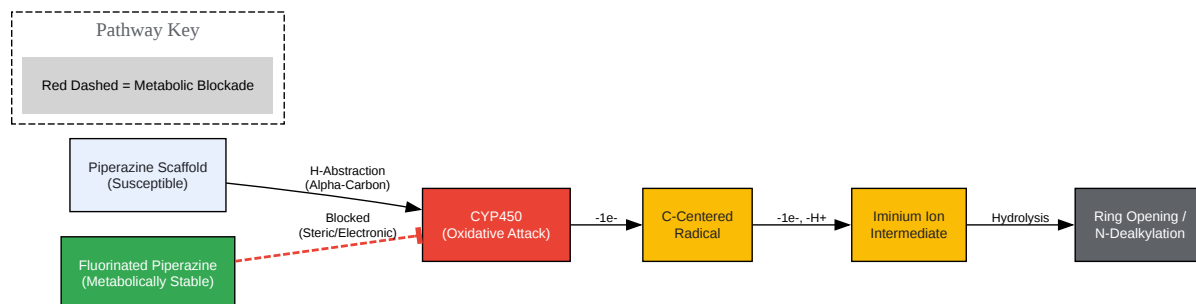

[Click to download full resolution via product page](#)

Figure 1: Mechanism of CYP450-mediated oxidation of piperazine and the blocking effect of fluorination.[1][2]

Comparative Performance Analysis

The following data highlights the impact of fluorination on half-life (

) and intrinsic clearance (

) in Human Liver Microsomes (HLM).

Table 1: Representative Stability Profile (SAR Trends)

Data synthesized from medicinal chemistry optimization campaigns (e.g., piperazinyl-pyridazines and aryl-piperazines).

Compound Class	Structure Description	HLM (min)	()	Metabolic Liability
Unsubstituted Piperazine	Basic piperazine core	< 5	> 150 (High)	Rapid -hydroxylation & N-dealkylation.
2-Fluoro-Piperazine	Single F at -carbon	15 - 30	40 - 80 (Mod)	Partial blockade; chirality introduced.
2,2-Difluoro-Piperazine	Gem-difluoro at -carbon	> 60	< 20 (Low)	Complete blockade of one oxidative site; reduced basicity.
Trifluoromethyl-Analog	on N-aryl ring	> 100	< 10 (Low)	Steric shielding + electronic deactivation of the ring.

Case Study: Optimization of Piperazin-1-ylpyridazines

In a study optimizing dCTPase inhibitors, researchers faced rapid clearance with a piperazine lead.

- Lead Compound (Non-fluorinated):

in HLM.[3]

- Strategy: "Fluorine-blocking" the aromatic ring attached to the piperazine and introducing electron-withdrawing groups.
- Result (Compound 29):
increased to > 100 min.

- Insight: Fluorination not only protected the specific carbon it was attached to but also reduced the electron density of the entire system, making the piperazine nitrogen less prone to oxidation [1].

Validated Experimental Protocol

To generate reproducible stability data, follow this self-validating microsomal stability protocol.

Materials

- Test System: Pooled Human Liver Microsomes (HLM) (20 mg/mL protein conc).
- Cofactor: NADPH regenerating system or 10 mM NADPH solution.
- Buffer: 100 mM Potassium Phosphate (pH 7.4).
- Quench Solution: Ice-cold Acetonitrile (ACN) containing Internal Standard (IS) (e.g., Tolbutamide or Propranolol).

Workflow Diagram

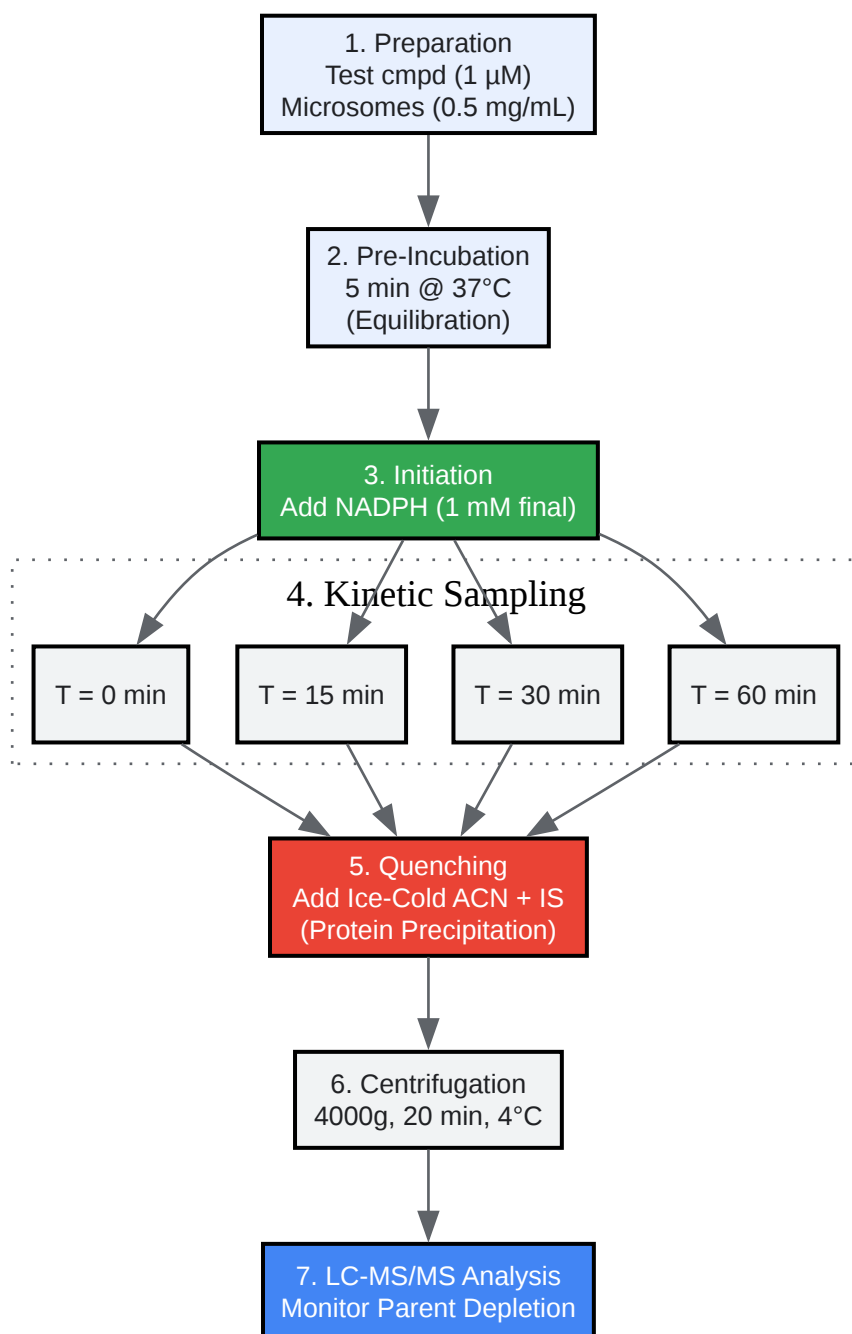

[Click to download full resolution via product page](#)

Figure 2: Step-by-step workflow for in vitro microsomal stability assay.

Step-by-Step Methodology

- Master Mix Prep: Prepare a solution containing phosphate buffer and microsomes (final protein conc).

).

- Compound Addition: Spike the master mix with the test compound (fluorinated piperazine) to a final concentration of

. Note: Keep concentration low (

) to ensure first-order kinetics.

- Pre-incubation: Warm the mixture at

for 5 minutes.

- Initiation: Add NADPH (1 mM final concentration) to start the reaction.

- Sampling: At defined time points (0, 5, 15, 30, 45, 60 min), remove aliquots (

).

- Quenching: Immediately dispense aliquots into plates containing

ice-cold acetonitrile with Internal Standard.

- Processing: Centrifuge at

for 20 min to pellet proteins. Inject supernatant onto LC-MS/MS.

Data Interpretation & Calculations

Calculating Half-Life (

)

Plot the natural logarithm (

) of the remaining parent compound (% remaining) versus time. The slope (

) of the linear regression represents the elimination rate constant.

Calculating Intrinsic Clearance (

)

Convert the half-life into intrinsic clearance, normalized for protein concentration.

Benchmarking:

- Low Clearance:

(Ideal for drug candidates).

- Moderate Clearance:

.

- High Clearance:

(Likely requires structural modification, e.g., further fluorination).

Troubleshooting & Optimization

- Issue: Non-Specific Binding (NSB). Fluorinated compounds can be more lipophilic.
 - Solution: Include a "buffer only" (no microsomes) control to check for compound loss to the plasticware.
- Issue: Low Ionization Signal. Fluorine is electronegative and can suppress ionization in ESI+.
 - Solution: Optimize MS source parameters; consider negative mode if the molecule has acidic protons, or use APCI.
- Issue: Unexpected Metabolites.
 - Solution: Perform a Metabolite ID (MetID) scan.^{[1][4]} Fluorine may shift metabolism to a different part of the molecule (metabolic switching).

References

- Structure–metabolism–relationships in the microsomal clearance of piperazin-1-ylpyridazines. Source: NIH / PubMed Central. URL:[[Link](#)]

- Metabolic Stability of Fluorinated Small Molecules: A Physical Organic Chemistry Perspective. Source: ChemRxiv / NIH. URL:[[Link](#)][3][5]
- Metabolic interactions with piperazine-based 'party pill' drugs. Source: PubMed.[1] URL: [[Link](#)]
- Comparison of intrinsic clearances in human liver microsomes and suspended hepatocytes. Source: Xenobiotica.[6] URL:[[Link](#)]

Need Custom Synthesis?

BenchChem offers custom synthesis for rare earth carbides and specific isotopic labeling.

Email: info@benchchem.com or [Request Quote Online](#).

Sources

- 1. On the Metabolic Stability of Fluorinated Small Molecules: A Physical Organic Chemistry Perspective - PMC [[pmc.ncbi.nlm.nih.gov](https://pubmed.ncbi.nlm.nih.gov)]
- 2. [researchgate.net](https://www.researchgate.net) [[researchgate.net](https://www.researchgate.net)]
- 3. Structure–metabolism-relationships in the microsomal clearance of piperazin-1-ylpyridazines - PMC [[pmc.ncbi.nlm.nih.gov](https://pubmed.ncbi.nlm.nih.gov)]
- 4. discovery.dundee.ac.uk [discovery.dundee.ac.uk]
- 5. Metabolic interactions with piperazine-based 'party pill' drugs - PubMed [pubmed.ncbi.nlm.nih.gov]
- 6. [research.manchester.ac.uk](https://www.research.manchester.ac.uk) [[research.manchester.ac.uk](https://www.research.manchester.ac.uk)]
- To cite this document: BenchChem. [In Vitro Metabolic Stability Guide: Fluorinated vs. Non-Fluorinated Piperazines]. BenchChem, [2026]. [Online PDF]. Available at: [<https://www.benchchem.com/product/b8785294/docs#in-vitro-metabolic-stability-guide-fluorinated-vs-non-fluorinated-piperazines>]

Disclaimer & Data Validity:

The information provided in this document is for Research Use Only (RUO) and is strictly not intended for diagnostic or therapeutic procedures. While BenchChem strives to provide

accurate protocols, we make no warranties, express or implied, regarding the fitness of this product for every specific experimental setup.

Technical Support: The protocols provided are for reference purposes. Unsure if this reagent suits your experiment?

Need Industrial/Bulk Grade? [Request Custom Synthesis Quote](#)

BenchChem

Our mission is to be the trusted global source of essential and advanced chemicals, empowering scientists and researchers to drive progress in science and industry.

Contact

Address: 3281 E Guasti Rd

Ontario, CA 91761, United States

Phone: (601) 213-4426

Email: info@benchchem.com

[Contact our Ph.D. Support Team for a compatibility check](#)