

# Application Note: Preparation of Photo-Reversible Hydrogels Crosslinked with 4-Aminocinnamic Acid[1]

**Author:** BenchChem Technical Support Team. **Date:** April 2026

## Compound of Interest

Compound Name: 4-Aminocinnamic acid  
hydrochloride

Cat. No.: B8783508

[Get Quote](#)

## Introduction & Scientific Rationale

The development of "smart" hydrogels that respond to external stimuli is a cornerstone of modern tissue engineering and drug delivery. Hydrogels crosslinked with 4-Aminocinnamic acid (4-ACA) offer a unique advantage: photo-reversibility. Unlike permanent covalent crosslinks (e.g., glutaraldehyde, methacrylate), the dimerization of cinnamic acid derivatives is a reversible [2+2] cycloaddition.

- Forward Reaction (Gelation): Irradiation at

nm (typically 365 nm) triggers the dimerization of pendant cinnamoyl groups, forming a cyclobutane ring (truxillic/truxinic acid derivatives) that crosslinks the polymer chains.

- Reverse Reaction (Sol-Gel Transition): Irradiation at

nm (typically 254 nm) cleaves the cyclobutane ring, reverting the network to a sol state.

This guide focuses on the functionalization of Hyaluronic Acid (HA) with 4-ACA, followed by photocrosslinking. HA is selected as the backbone due to its ubiquity in biomedical applications, though the chemistry is adaptable to other carboxyl-containing polymers (e.g., Alginate, Gelatin) or amine-containing polymers (e.g., Chitosan, using the carboxyl of 4-ACA).

## Mechanism of Action

The core mechanism relies on the alignment of two cinnamoyl moieties. Upon UV excitation, the

electrons of the alkene bonds interact to form a covalent cyclobutane bridge.

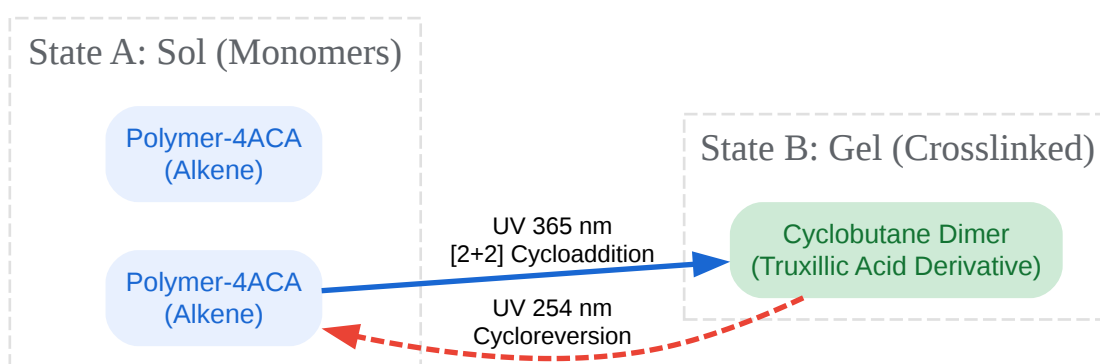

[Click to download full resolution via product page](#)

Figure 1: Reversible photocrosslinking mechanism of 4-ACA functionalized polymers.

## Pre-Protocol Considerations

### Material Selection

Component	Specifications	Role
Hyaluronic Acid (HA)	MW: 50 kDa - 1.5 MDa	Polymer Backbone.[1] Higher MW yields stiffer gels but higher viscosity solutions.
4-Aminocinnamic Acid	>98% Purity	Photo-active moiety. Contains amine (for coupling) and alkene (for crosslinking).
EDC	1-Ethyl-3-(3-dimethylaminopropyl)carbodiimide	Zero-length crosslinker to activate HA carboxyls.
NHS	N-Hydroxysuccinimide	Stabilizes the active ester intermediate.
MES Buffer	0.1 M, pH 4.75 - 6.0	Optimal pH range for EDC coupling efficiency.

## Safety & Handling

- 4-ACA: Light sensitive.[2] Store in amber vials. Handle under low light or yellow light to prevent premature dimerization.
- UV Radiation: Wear UV-protective eyewear and skin covering when operating 365 nm or 254 nm light sources.

## Detailed Protocol

### Phase 1: Synthesis of HA-ACA Conjugate

This step attaches 4-ACA to the HA backbone via an amide bond formed between the amine of 4-ACA and the carboxyl of HA.

Workflow Diagram:

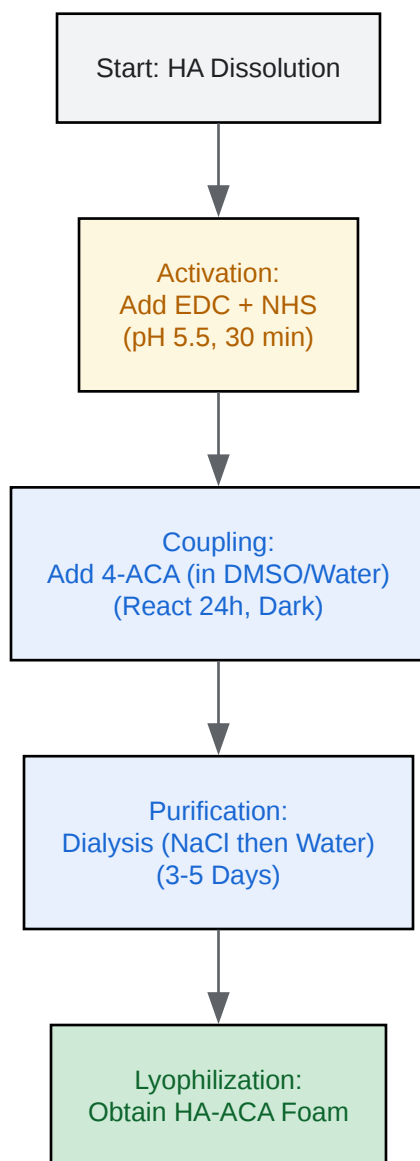

[Click to download full resolution via product page](#)

Figure 2: Synthesis workflow for HA-ACA conjugation.

#### Step-by-Step Procedure:

- Dissolution:
  - Dissolve 1.0 g of Sodium Hyaluronate (HA) in 100 mL of MES Buffer (0.1 M, pH 5.5).
  - Stir overnight to ensure complete hydration. Final concentration: 1% (w/v).

- Activation:
  - Add EDC (molar ratio 2:1 relative to HA carboxyl groups) and NHS (molar ratio 2:1 relative to HA carboxyl groups) to the solution.
  - Calculation Note: The repeating unit of HA (Glucuronic acid + N-acetylglucosamine) has a MW of ~400 Da. 1g HA  
2.5 mmol COOH groups.
  - Stir for 30 minutes at room temperature to form the NHS-ester.
- Conjugation:
  - Dissolve 4-Aminocinnamic Acid (4-ACA) in a minimal volume of DMSO or DMF (e.g., 5-10 mL).
  - Target Degree of Substitution (DS): For a DS of 20%, add 0.5 mmol of 4-ACA.
  - Add the 4-ACA solution dropwise to the activated HA solution.
  - Adjust pH back to 5.5–6.0 if necessary.
  - CRITICAL: Wrap the reaction vessel in aluminum foil to protect from light. React for 24 hours at room temperature with stirring.
- Purification:
  - Transfer the reaction mixture to dialysis tubing (MWCO 3.5 kDa or 10 kDa).
  - Dialyze against 0.1 M NaCl for 2 days (change solution 3 times) to remove unreacted electrostatic complexes.
  - Dialyze against Distilled Water for 3 days (change solution daily) to remove salts and solvents.
  - Note: Perform dialysis in the dark or cover containers with foil.
- Recovery:

- Filter the solution through a 0.45  $\mu\text{m}$  filter to remove any aggregates.
- Lyophilize (freeze-dry) the solution to obtain the HA-ACA conjugate as a white/off-white cotton-like solid.
- Store at  $-20^{\circ}\text{C}$  in the dark.

## Phase 2: Hydrogel Fabrication & Photocrosslinking

- Sol Preparation:
  - Dissolve the lyophilized HA-ACA in PBS (pH 7.4) or cell culture media to a concentration of 2-5% (w/v).
  - Allow to dissolve completely (2-4 hours).
- Gelation (Crosslinking):
  - Pipette the solution into a mold (e.g., PDMS mold, well plate, or between glass slides with spacers).
  - Irradiate with a UV lamp at 365 nm.[2]
  - Intensity: 10–20  $\text{mW}/\text{cm}^2$ .
  - Time: 10–30 minutes.
  - Observation: The solution should transition to a stable gel. The gelation point can be verified by the "inversion method" (gel does not flow when vial is inverted).

## Phase 3: Reversibility (Optional)

To demonstrate reversibility or degrade the gel:

- Expose the hydrogel to UV light at 254 nm.
- Time: Depending on thickness, 10–60 minutes.

- The gel will soften and eventually return to a liquid state as the cyclobutane rings are cleaved.

## Characterization & Validation

Method	Parameter Measured	Expected Outcome
UV-Vis Spectroscopy	Absorbance at 280-300 nm	Decrease in peak intensity upon 365 nm irradiation (consumption of C=C bonds). Increase upon 254 nm irradiation.
1H-NMR	Degree of Substitution (DS)	Peaks at 6.5–7.5 ppm (aromatic protons of ACA) and 6.4/7.6 ppm (vinyl protons). Compare integration to HA methyl peak (1.9 ppm).
Rheology	Storage Modulus (G')	G' increases significantly upon UV exposure, surpassing Loss Modulus (G'').
Swelling Ratio	Water uptake	Measure wet weight vs. dry weight. Higher crosslinking density = Lower swelling ratio.

## Troubleshooting Guide

- Issue: Gelation is too slow or gel is too weak.
  - Cause: Low Degree of Substitution (DS) or insufficient UV intensity.
  - Solution: Increase the molar ratio of 4-ACA during synthesis. Ensure UV source is actually emitting at 365 nm (check with radiometer). Increase polymer concentration (e.g., from 2% to 4%).

- Issue: Polymer precipitates during synthesis.
  - Cause: 4-ACA is hydrophobic. Adding it too fast or in too much organic solvent can crash the hydrophilic HA.
  - Solution: Add 4-ACA/DMSO solution very slowly. Keep the organic solvent fraction <10-15% of the total volume.
- Issue: No reversibility observed.
  - Cause: 254 nm light has low penetration depth.
  - Solution: This mechanism works best for thin films or hydrogels <1-2 mm thick. For bulk gels, erosion will be surface-limited.

## References

- Radical-Free Photocrosslinking
  - Mechanism:[2] 4-ACA dimerization avoids the need for photoinitiators (like Irgacure), making it highly cytocompatible.
  - Source:
- Hyaluronic Acid Modification
  - Protocol Basis: Standard EDC/NHS coupling of amines to HA carboxyls.
  - Source:
- Photodimerization Kinetics
  - Solid State vs. Gel: The [2+2] cycloaddition is topochemically controlled but proceeds efficiently in hydrogel networks due to polymer chain mobility.
  - Source:[3]
- Chitosan Alternatives

- Alternative Route: Conjugation of 4-ACA carboxyls to Chitosan amines.[4]
- Source:

#### Need Custom Synthesis?

BenchChem offers custom synthesis for rare earth carbides and specific isotopic labeling.

Email: [info@benchchem.com](mailto:info@benchchem.com) or [Request Quote Online](#).

## Sources

- [1. Synthesis and Characterization of Conjugated Hyaluronic Acids. Application to Stability Studies of Chitosan-Hyaluronic Acid Nanogels Based on Fluorescence Resonance Energy Transfer - PMC \[pmc.ncbi.nlm.nih.gov\]](#)
- [2. Photocrosslinkable natural polymers in tissue engineering - PMC \[pmc.ncbi.nlm.nih.gov\]](#)
- [3. Single crystal to single crystal \[2+2\] photoreactions in chloride and sulphate salts of 4-amino-cinnamic acid via solid-solution formation: a structural and kinetic study - Chemical Communications \(RSC Publishing\) \[pubs.rsc.org\]](#)
- [4. Biomedical Engineering Society \(Singapore\) - ICBP2015-programme \[bes.org.sg\]](#)
- [To cite this document: BenchChem. \[Application Note: Preparation of Photo-Reversible Hydrogels Crosslinked with 4-Aminocinnamic Acid\[1\]\]. BenchChem, \[2026\]. \[Online PDF\]. Available at: \[https://www.benchchem.com/product/b8783508/docs#application-note-preparation-of-photo-reversible-hydrogels-crosslinked-with-4-aminocinnamic-acid-1\]](#)

---

### Disclaimer & Data Validity:

The information provided in this document is for Research Use Only (RUO) and is strictly not intended for diagnostic or therapeutic procedures. While BenchChem strives to provide accurate protocols, we make no warranties, express or implied, regarding the fitness of this product for every specific experimental setup.

**Technical Support:** The protocols provided are for reference purposes. Unsure if this reagent suits your experiment?

**Need Industrial/Bulk Grade?** [Request Custom Synthesis Quote](#)

# BenchChem

Our mission is to be the trusted global source of essential and advanced chemicals, empowering scientists and researchers to drive progress in science and industry.

## Contact

Address: 3281 E Guasti Rd

Ontario, CA 91761, United States

Phone: (601) 213-4426

Email: [info@benchchem.com](mailto:info@benchchem.com)

[Contact our Ph.D. Support Team for a compatibility check](#)