

Literature Review & Comparison Guide: Synthesis Pathways for 2-Methyl-3-Substituted Indoles

Author: BenchChem Technical Support Team. **Date:** May 2026

Compound of Interest

Compound Name:	3-(2-Bromoethyl)-2-methyl-1H-indole
CAS No.:	56365-56-1
Cat. No.:	B8779452

[Get Quote](#)

Executive Summary: The Strategic Value of the Scaffold

The 2-methyl-3-substituted indole scaffold is a privileged pharmacophore in medicinal chemistry, serving as the structural core for non-steroidal anti-inflammatory drugs (NSAIDs) like Indomethacin, CRTH2 antagonists, and emerging antimicrobial agents. The C2-methyl group is not merely a bystander; it often restricts conformational freedom, enhancing binding affinity, or blocks metabolic oxidation at the reactive C2 position.

This guide critically reviews three distinct synthetic paradigms for accessing this scaffold:

- De Novo Cyclization (Fischer Synthesis): The historical gold standard for scale and reliability.
- Direct C3-Functionalization: The modern approach for late-stage diversification of the commercially available 2-methylindole core.

- Transition Metal-Catalyzed Annulation: A high-precision method for complex substrates.

Pathway A: The Classical De Novo Approach (Fischer Indole Synthesis)

Despite being discovered in 1883, the Fischer Indole Synthesis remains the dominant method for manufacturing 2-methyl-3-substituted indoles due to its robustness and scalability.

Mechanistic Insight

The reaction proceeds through the acid-catalyzed condensation of a phenylhydrazine with a ketone (specifically ethyl methyl ketone or similar derivatives for this target), followed by a [3,3]-sigmatropic rearrangement.

Critical Control Point: The regioselectivity of hydrazone formation. Using unsymmetrical ketones like ethyl methyl ketone typically favors the formation of the more substituted enamine (thermodynamic control), leading to the 2-methyl-3-ethyl indole product. However, steric bulk and acid strength can shift this ratio.

Experimental Protocol: ZnCl₂-Mediated Cyclization

Source: Adapted from BenchChem & Alfa Chemistry Protocols

Reagents: Phenylhydrazine (1.0 equiv), Ethyl Methyl Ketone (1.1 equiv), Anhydrous ZnCl₂ (2.0 equiv), Acetic Acid (Solvent).

- Hydrazone Formation: Mix phenylhydrazine and ethyl methyl ketone in acetic acid at 0°C. Stir for 30 minutes.
- Cyclization: Add anhydrous ZnCl₂ to the reaction vessel. Heat the mixture to reflux (110-120°C) for 2-4 hours. Note: The reaction is exothermic; monitor internal temperature.
- Quench: Cool to room temperature and pour into ice-cold water.
- Workup: Extract with ethyl acetate (3x). Wash organic layer with NaHCO₃ (sat.) to remove acid, then brine. Dry over Na₂SO₄.

- Purification: Recrystallization from ethanol/water is often sufficient; otherwise, silica gel chromatography (Hexane/EtOAc).

Performance Metrics:

- Yield: 65-85% (High)
- Scalability: Excellent (Kg scale).
- Limitations: Intolerant to acid-sensitive functional groups (acetals, Boc-groups).

Pathway B: Direct C3-Functionalization of 2-Methylindole

For projects requiring the rapid generation of analogs (SAR studies), building the ring from scratch is inefficient. Direct functionalization of the C3 position of 2-methylindole is the preferred strategy.

B(C₆F₅)₃-Catalyzed C3-Alkylation

A breakthrough method utilizing the Lewis acid Tris(pentafluorophenyl)borane to activate amines or alcohols for electrophilic attack at C3. This avoids the use of toxic alkyl halides and prevents N-alkylation side reactions.

Mechanism: The borane catalyst activates the leaving group (e.g., an amine or alcohol), generating a transient carbocation or activated complex that is intercepted by the nucleophilic C3 of the indole.

Experimental Protocol: Borane-Catalyzed Alkylation

Source: Adapted from ACS Catalysis (2020)

Reagents: 2-Methylindole (1.0 equiv), Benzyl methyl ether or Benzyl amine derivative (1.2 equiv), B(C₆F₅)₃ (5-10 mol%), Toluene or DCE.

- Setup: In a glovebox or under N₂, charge a vial with 2-methylindole, the alkylating agent, and the catalyst.

- Reaction: Dissolve in anhydrous Toluene (0.5 M). Seal and heat to 80-100°C for 12-24 hours.
- Workup: Filter through a short pad of silica to remove the catalyst. Concentrate in vacuo.
- Purification: Flash column chromatography.

Performance Metrics:

- Yield: 70-95% (Excellent).
- Selectivity: >95% C3-selectivity (Minimal N-alkylation).
- Green Metric: High atom economy if using alcohols (water is the only byproduct).

Pathway C: Transition Metal-Catalyzed Annulation

This pathway is reserved for constructing highly substituted indoles where the Fischer method fails due to regioselectivity issues or harsh conditions.

Ruthenium-Catalyzed Cycloisomerization

This method utilizes 2-alkynylanilines.^[1] A unique feature highlighted in recent literature is the ability to induce a 1,2-carbon migration, allowing access to 3-substituted indoles that are difficult to synthesize otherwise.

Protocol Summary: Reaction of 2-alkynylaniline with [CpRuCl(dppe)] (3 mol%) and a halide scavenger (NaBARF₄) in chlorobenzene at 100°C.

- Yield: Moderate to Good (50-80%).
- Advantage: Mild, neutral conditions; tolerates sensitive functional groups.

Comparative Analysis & Decision Matrix

The following table synthesizes data from recent literature (2015-2025) to guide method selection.

Feature	Fischer Synthesis (ZnCl ₂)	Direct C3-Alkylation (Borane)	Ru-Catalyzed Annulation
Primary Use Case	Bulk manufacturing of core scaffold	Late-stage SAR / Analog generation	Complex/Sensitive substrates
Starting Material	Phenylhydrazine + Ketone	2-Methylindole + Electrophile	2-Alkynylaniline
Step Count	2 (One-pot possible)	1	3-4 (to make precursor)
Atom Economy	Moderate (Loss of NH ₃ & H ₂ O)	High (Loss of H ₂ O or amine)	High (Isomerization)
Reaction Conditions	Harsh (Acidic, High T)	Mild to Moderate	Neutral, Moderate T
Yield (Typical)	65 - 85%	70 - 95%	50 - 80%
Key Limitation	Regioselectivity with unsym. ketones	Requires e-rich indole core	Expensive catalyst & precursors

Visualizing the Pathways

Diagram 1: Mechanistic Flow of Fischer Synthesis vs. C3-Functionalization

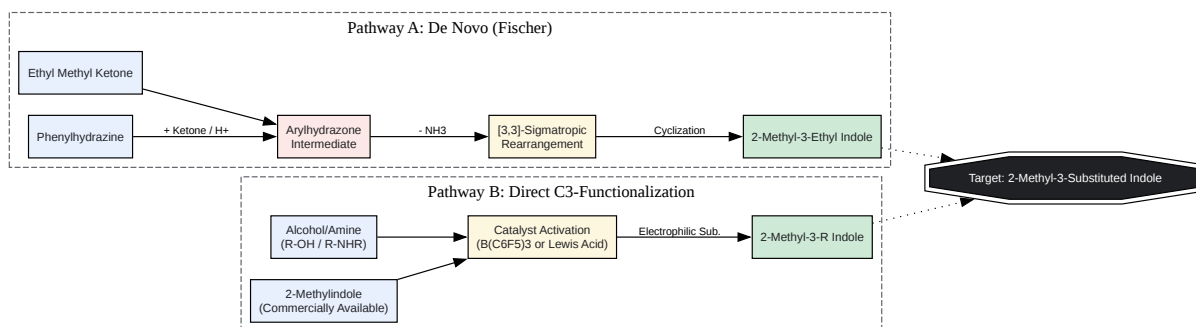

[Click to download full resolution via product page](#)

Caption: Comparison of De Novo construction (Fischer) versus Direct Functionalization pathways.

Diagram 2: Decision Logic for Method Selection

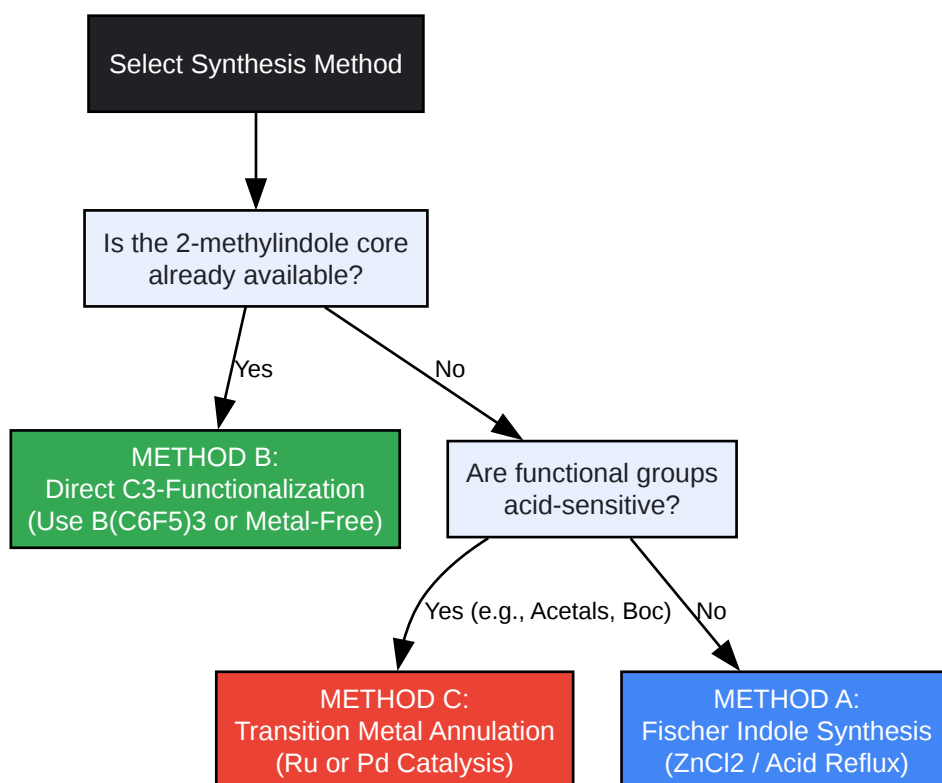

[Click to download full resolution via product page](#)

Caption: Decision matrix for selecting the optimal synthesis pathway based on substrate availability and sensitivity.

References

- BenchChem. "Protocol for Fischer Indole Synthesis of 2-Methylindoles." BenchChem Application Notes, 2025. [Link](#)
- Alfa Chemistry. "Fischer Indole Synthesis: Mechanism and Protocols." Alfa Chemistry Resources. [Link](#)
- Zhang, L., et al. "B(C6F5)3-Catalyzed Direct C3 Alkylation of Indoles and Oxindoles." ACS Catalysis, vol. 10, no.[2] 17, 2020, pp. 10157-10168.[2] [Link](#)
- Pazur, E. J., et al. "Direct C3-functionalization of indoles with α -heteroaryl-substituted methyl alcohols via a metal-free hydrogen autotransfer-type reaction." ChemRxiv, 2021. [Link](#)

- Takahashi, M., et al. "Ruthenium-Catalyzed Cycloisomerization of 2-Alkynylanilides: Synthesis of 3-Substituted Indoles by 1,2-Carbon Migration." *Journal of the American Chemical Society*, vol. 139, no. 20, 2017. [Link](#)
- Simoneau, C. A., & Ganem, B. "A three-component Fischer indole synthesis." [3] *Nature Protocols*, vol. 3, 2008, pp. 1249–1252. [3] [Link](#)

Need Custom Synthesis?

BenchChem offers custom synthesis for rare earth carbides and specific isotopic labeling.

Email: info@benchchem.com or [Request Quote Online](#).

Sources

- 1. pubs.acs.org [pubs.acs.org]
- 2. pubs.acs.org [pubs.acs.org]
- 3. A three-component Fischer indole synthesis - PubMed [pubmed.ncbi.nlm.nih.gov]
- To cite this document: BenchChem. [Literature Review & Comparison Guide: Synthesis Pathways for 2-Methyl-3-Substituted Indoles]. BenchChem, [2026]. [Online PDF]. Available at: [<https://www.benchchem.com/product/b8779452/docs#literature-review-comparison-guide-synthesis-pathways-for-2-methyl-3-substituted-indoles>]

Disclaimer & Data Validity:

The information provided in this document is for Research Use Only (RUO) and is strictly not intended for diagnostic or therapeutic procedures. While BenchChem strives to provide accurate protocols, we make no warranties, express or implied, regarding the fitness of this product for every specific experimental setup.

Technical Support: The protocols provided are for reference purposes. Unsure if this reagent suits your experiment?

Need Industrial/Bulk Grade? [Request Custom Synthesis Quote](#)

BenchChem

Our mission is to be the trusted global source of essential and advanced chemicals, empowering scientists and researchers to drive progress in science and industry.

Contact

Address: 3281 E Guasti Rd

Ontario, CA 91761, United States

Phone: (601) 213-4426

Email: info@benchchem.com

[Contact our Ph.D. Support Team for a compatibility check](#)