

Application Note: High-Efficiency Nucleophilic Substitution of -Chloroketones

Author: BenchChem Technical Support Team. **Date:** April 2026

Compound of Interest

Compound Name: 1-chloroheptan-2-one

CAS No.: 41055-92-9

Cat. No.: B8761297

[Get Quote](#)

Executive Summary

This application note details the optimized protocol for the nucleophilic substitution of **1-chloroheptan-2-one** (an

-chloroketone) to generate 1-azidoheptan-2-one. This transformation is a critical gateway in drug discovery, serving as a precursor for 1,2,3-triazoles (via Click chemistry) and

-aminoketones (via Staudinger reduction).

Unlike simple alkyl halides, **1-chloroheptan-2-one** exhibits enhanced reactivity due to the adjacent carbonyl group. However, this same feature introduces risks of self-condensation and lachrymatory hazards. This guide provides a robust, self-validating methodology that balances kinetic acceleration with safety and purity.

Mechanistic Insight & Reactivity Profile

The "Carbonyl Boost" in Reactions

The reactivity of **1-chloroheptan-2-one** toward nucleophiles (like the azide ion,

) is significantly higher than that of 1-chloroheptane. This is not due to steric factors but rather electronic orbital overlap.

- Inductive Effect: The carbonyl group is electron-withdrawing, creating a larger partial positive charge () on the -carbon.
- Orbital Stabilization: The transition state of the attack is stabilized by the overlap of the incoming nucleophile's orbital with the orbital of the carbonyl group. This lowers the activation energy ().^{[1][2]}

Competing Pathways

Researchers must control conditions to favor Path A (Substitution) over competing side reactions:

- Path A (): Direct displacement of Cl by . (Desired)
- Path B (Elimination): Formation of the enone (hept-1-en-2-one). (Unlikely with weak bases like , but possible with strong alkoxides).
- Path C (Favorskii Rearrangement): Skeletal rearrangement via a cyclopropanone intermediate. (Requires strong base/alkoxide).

Mechanistic Pathway Diagram

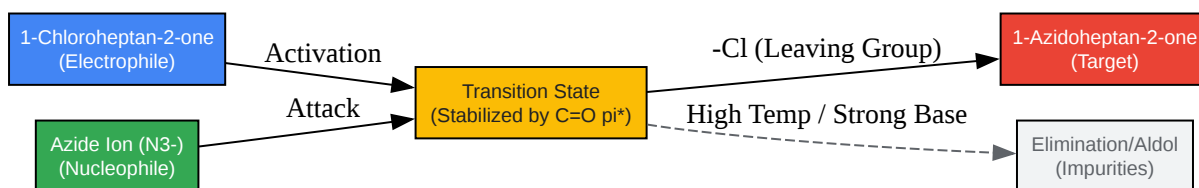

[Click to download full resolution via product page](#)

Figure 1: Mechanistic flow of the

reaction on an

-chloroketone.

Experimental Protocol

Reagents & Materials Table

Component	Role	Equiv.	Notes
1-Chloroheptan-2-one	Substrate	1.0	Lachrymator.[3][4] Handle in fume hood.
Sodium Azide ()	Nucleophile	1.2 - 1.5	Toxic/Explosive. Avoid acid contact.[3]
Acetone	Solvent	-	Solubilizes organic substrate.
Water	Co-Solvent	-	Solubilizes ionic azide.
Tetrabutylammonium Iodide (TBAI)	Catalyst	0.05	Phase transfer catalyst (Optional for speed).

Step-by-Step Methodology

Safety Pre-Check:

- Ensure all glassware is free of heavy metals (Cu, Pb) to prevent heavy metal azide formation.
- Warning: **1-chloroheptan-2-one** is a potent lachrymator (tear gas agent). Double-glove and use a functioning fume hood.

Step 1: Reaction Setup

- Dissolve Sodium Azide (1.5 equiv) in a minimal amount of water (approx. 1 mL per mmol).
- In a separate round-bottom flask, dissolve **1-chloroheptan-2-one** (1.0 equiv) in Acetone (approx. 3 mL per mmol).
- Optional: Add TBAI (5 mol%) to the acetone solution to accelerate the reaction via the Finkelstein effect (in situ formation of transient iodo-species).

Step 2: Execution

- Cool the acetone solution to 0°C (ice bath) to control the initial exotherm.
- Add the aqueous azide solution dropwise to the acetone solution.
- Allow the mixture to warm to Room Temperature (20-25°C).
- Stir vigorously for 4–6 hours.
 - Monitoring: Spot TLC (Hexane:EtOAc 8:2). The starting material () should disappear; product () will appear. Staining with Anisaldehyde is recommended for ketones.

Step 3: Workup (Critical for Safety)

- Dilution: Dilute the reaction mixture with Diethyl Ether or Ethyl Acetate (Do NOT use Dichloromethane; DCM can react with azides to form explosive Diazidomethane).
- Washing: Wash the organic layer with water (

) to remove unreacted

and inorganic salts.

- Drying: Dry the organic phase over anhydrous

.

- Concentration: Concentrate under reduced pressure at

(Azides can be heat sensitive).

Step 4: Storage

- Store the resulting 1-azidoheptan-2-one in the dark at -20°C. Do not distill unless absolutely necessary (explosion hazard).

Workflow Visualization

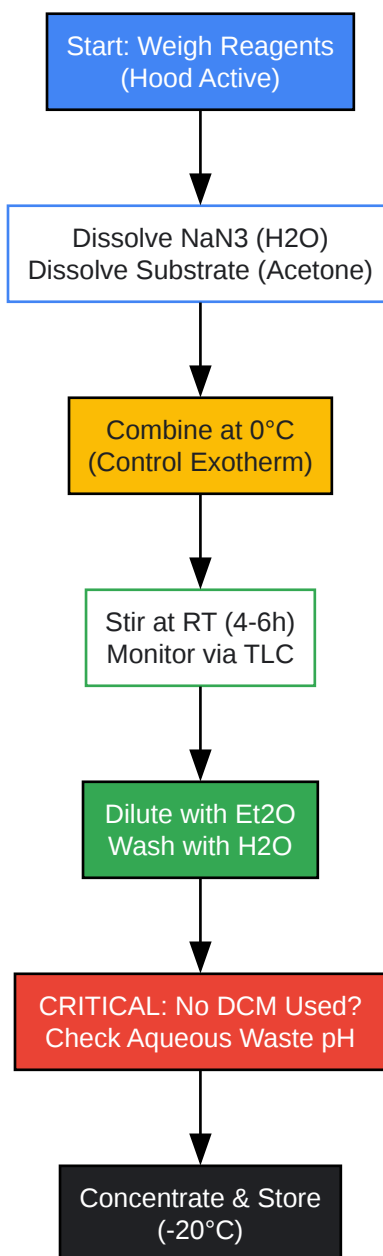

[Click to download full resolution via product page](#)

Figure 2: Operational workflow for the synthesis of 1-azidoheptan-2-one.

Troubleshooting & Optimization

Observation	Root Cause	Corrective Action
Low Conversion	Poor solubility of in organic phase.	Increase Water ratio or add TBAI (Phase Transfer Catalyst).
New Spot (Lower)	Hydrolysis of Cl to OH (1- hydroxyheptan-2-one).	Reaction pH is too basic or temp too high. Keep neutral; keep at RT.
Darkening of Color	Polymerization/Condensation.	Substrate concentration too high. Dilute to 0.1 M.
Emulsion in Workup	Surfactant effect of long chain (C7).[5]	Add Brine (Sat. NaCl) to aqueous wash.

References

- National Institutes of Health (PMC). (2003). The Chemistry of α -Haloketones and Their Utility in Heterocyclic Synthesis. Retrieved from [\[Link\]](#)
- Master Organic Chemistry. (2012). Nucleophilic Substitution Reactions - Introduction. Retrieved from [\[Link\]](#)

Need Custom Synthesis?

BenchChem offers custom synthesis for rare earth carbides and specific isotopic labeling.

Email: info@benchchem.com or [Request Quote Online](#).

Sources

- [1. m.youtube.com](https://m.youtube.com) [m.youtube.com]
- [2. repository.up.ac.za](https://repository.up.ac.za) [repository.up.ac.za]
- [3. WERCS Studio - Application Error](https://assets.thermofisher.com) [assets.thermofisher.com]
- [4. fishersci.com](https://fishersci.com) [fishersci.com]
- [5. mdpi.com](https://mdpi.com) [mdpi.com]

- To cite this document: BenchChem. [Application Note: High-Efficiency Nucleophilic Substitution of -Chloroketones]. BenchChem, [2026]. [Online PDF]. Available at: [<https://www.benchchem.com/product/b8761297/docs#application-note-high-efficiency-nucleophilic-substitution-of-chloroketones>]

Disclaimer & Data Validity:

The information provided in this document is for Research Use Only (RUO) and is strictly not intended for diagnostic or therapeutic procedures. While BenchChem strives to provide accurate protocols, we make no warranties, express or implied, regarding the fitness of this product for every specific experimental setup.

Technical Support: The protocols provided are for reference purposes. Unsure if this reagent suits your experiment?

Need Industrial/Bulk Grade? [Request Custom Synthesis Quote](#)

BenchChem

Our mission is to be the trusted global source of essential and advanced chemicals, empowering scientists and researchers to drive progress in science and industry.

Contact

Address: 3281 E Guasti Rd
Ontario, CA 91761, United States
Phone: (601) 213-4426
Email: info@benchchem.com

[Contact our Ph.D. Support Team for a compatibility check](#)