

IR Spectroscopy Characterization of 3-Nitro-4-phenoxy pyridine: A Comparative Technical Guide

Author: BenchChem Technical Support Team. **Date:** April 2026

Compound of Interest

Compound Name: 3-Nitro-4-phenoxy pyridine

Cat. No.: B8759688

[Get Quote](#)

Executive Summary

3-Nitro-4-phenoxy pyridine represents a critical scaffold in medicinal chemistry, particularly as an intermediate for fused heterocycles like azaindoles and imidazopyridines used in kinase inhibition. Precise structural characterization of this molecule hinges on validating the nucleophilic aromatic substitution (

) of the phenoxy group onto the nitropyridine core.

This guide provides a technical comparison of Fourier Transform Infrared (FTIR) spectroscopy against computational (DFT) and structural alternatives. It details the specific vibrational fingerprints required to confirm the **3-nitro-4-phenoxy pyridine** structure, distinguishing it from its halogenated precursors and hydrolysis byproducts.

Part 1: The Vibrational Fingerprint (Technical Deep Dive)

To accurately characterize **3-Nitro-4-phenoxy pyridine**, one must deconstruct its spectrum into three interacting domains: the electron-deficient pyridine ring, the electron-withdrawing nitro group, and the electron-donating phenoxy ether linkage.

1. The Nitro Group (

)

The nitro group at the 3-position is the most diagnostic feature. Due to resonance conjugation with the pyridine ring, the

bonds exhibit distinct asymmetric and symmetric stretching modes.

- Asymmetric Stretch (): Typically appears at 1520–1540 cm^{-1} . The electron-withdrawing nature of the pyridine ring may shift this slightly higher compared to nitrobenzene.
- Symmetric Stretch (): Found at 1340–1360 cm^{-1} .
- Diagnostic Value: These bands confirm the integrity of the nitropyridine core during synthesis.

2. The Ether Linkage (

)

The formation of the ether bond is the primary reaction endpoint.

- Asymmetric Stretch: A strong, broad band at 1230–1260 cm^{-1} . This is the "fingerprint" of the successful phenoxy substitution.
- Symmetric Stretch: A sharper band at 1020–1050 cm^{-1} .

3. Aromatic Ring Systems (Pyridine vs. Phenyl)

Distinguishing the pyridine core from the pendant phenyl ring requires analyzing the out-of-plane (oop) bending regions.

- Pyridine Ring Breathing: ~1580–1600 cm^{-1} (often overlapping with phenyl modes).

- Phenoxy (Monosubstituted Benzene): Look for two strong peaks at $\sim 750\text{ cm}^{-1}$ and $\sim 690\text{ cm}^{-1}$ (C-H oop bending). These are absent in the starting material (4-chloro-3-nitropyridine) if it lacks a phenyl group.

Part 2: Comparative Analysis of Characterization

Methods[1]

This section compares the standard FTIR workflow against computational prediction (DFT) and Raman spectroscopy to help researchers choose the optimal validation strategy.

Method A: Experimental FTIR (ATR) vs. Method B: DFT Simulation

Is the "Digital Twin" accurate enough to replace the physical standard?

Feature	Method A: Experimental FTIR (ATR)	Method B: DFT Simulation (B3LYP/6-31G)*	Verdict
Band Position Accuracy	High. Real-world solvation and crystal packing effects are inherent.	Moderate. Gas-phase calculations often overestimate wavenumbers by 4-5% (scaling factor ~0.96 required).	Use DFT for assignment of complex overlapping bands; use FTIR for confirmation.
Sample Prep	Minimal. Solid-state ATR requires no KBr pelleting.	High. Requires significant computational time (CPU hours).	FTIR is faster for routine QC.
Nitro Group Specificity	Excellent. The doublet is unmistakable.	Excellent. Accurately predicts the Fermi resonance often seen in nitro compounds.	Tie. Both methods validate the group well.
Ether Detection	Superior. The C-O-C stretch is visually dominant.	Good, but intensity prediction can vary based on basis set.	FTIR is the gold standard for monitoring ether formation.

Comparative Analysis: Precursor vs. Product

The most critical comparison for the synthetic chemist.

Scenario: Monitoring the

reaction of 4-chloro-3-nitropyridine + Phenol

3-Nitro-4-phenoxy pyridine.

- Disappearance of C-Cl: The C-Cl stretch (approx. 700–750 cm^{-1}) is often obscured in the fingerprint region. Do not rely on this alone.

- Appearance of Ether Bands: The emergence of the 1240 cm^{-1} band is the primary indicator of conversion.
- Hydroxyl Loss: Pure product must lack the broad O-H stretch ($3200\text{--}3500\text{ cm}^{-1}$) of the unreacted phenol.

Part 3: Experimental Protocol & Workflow

Protocol: ATR-FTIR Characterization of **3-Nitro-4-phenoxy**pyridine

Objective: Validate the structure of synthesized **3-Nitro-4-phenoxy**pyridine using Attenuated Total Reflectance (ATR) FTIR.

Reagents & Equipment:

- Synthesized **3-Nitro-4-phenoxy**pyridine (solid).
- FTIR Spectrometer (e.g., PerkinElmer Spectrum Two or similar) with Diamond ATR accessory.
- Solvent: Isopropanol (for cleaning).

Step-by-Step Methodology:

- Background Collection:
 - Clean the diamond crystal with isopropanol and a lint-free wipe.
 - Collect an air background spectrum (32 scans, 4 cm^{-1} resolution). Ensure no peaks from residual solvent or atmospheric (2350 cm^{-1}) interfere.
- Sample Application:
 - Place approximately 2–5 mg of the solid sample onto the center of the crystal.
 - Apply pressure using the anvil arm. Monitor the "Live Preview" energy bar; aim for 60–80% throughput reduction to ensure good contact.

- Data Acquisition:
 - Scan range: 4000–600 cm^{-1} .
 - Accumulation: 16–32 scans.
 - Correction: Apply "ATR Correction" algorithm (if available) to account for penetration depth variance across wavenumbers.
- Spectral Validation Criteria (Pass/Fail):
 - Pass: Distinct doublet at ~1530/1350 (), strong band at ~1240 (Ether), peaks at 750/690 (Phenoxy).
 - Fail (Wet): Broad hump $>3000 \text{ cm}^{-1}$ (Water/Phenol contamination).
 - Fail (Hydrolysis): Strong carbonyl peak ~1650–1670 cm^{-1} indicates hydrolysis to 3-nitro-4-pyridone (common side reaction).

Workflow Diagram: Synthesis Monitoring

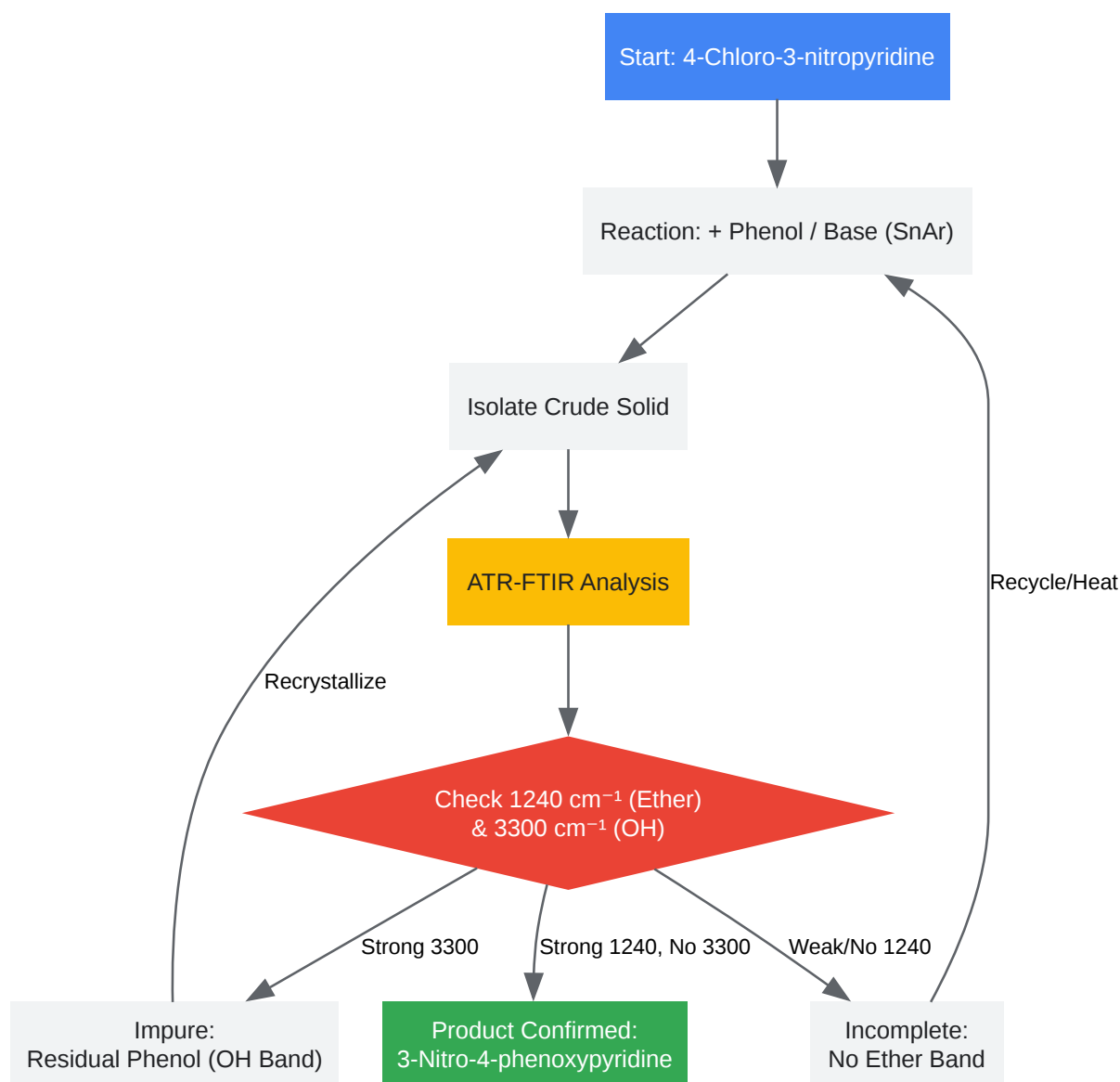

[Click to download full resolution via product page](#)

Caption: Logical workflow for monitoring the synthesis of **3-Nitro-4-phenoxy pyridine** using FTIR markers.

Part 4: Structural Validation Diagram

The following diagram illustrates the correlation between the molecular structure and the specific vibrational modes detected.

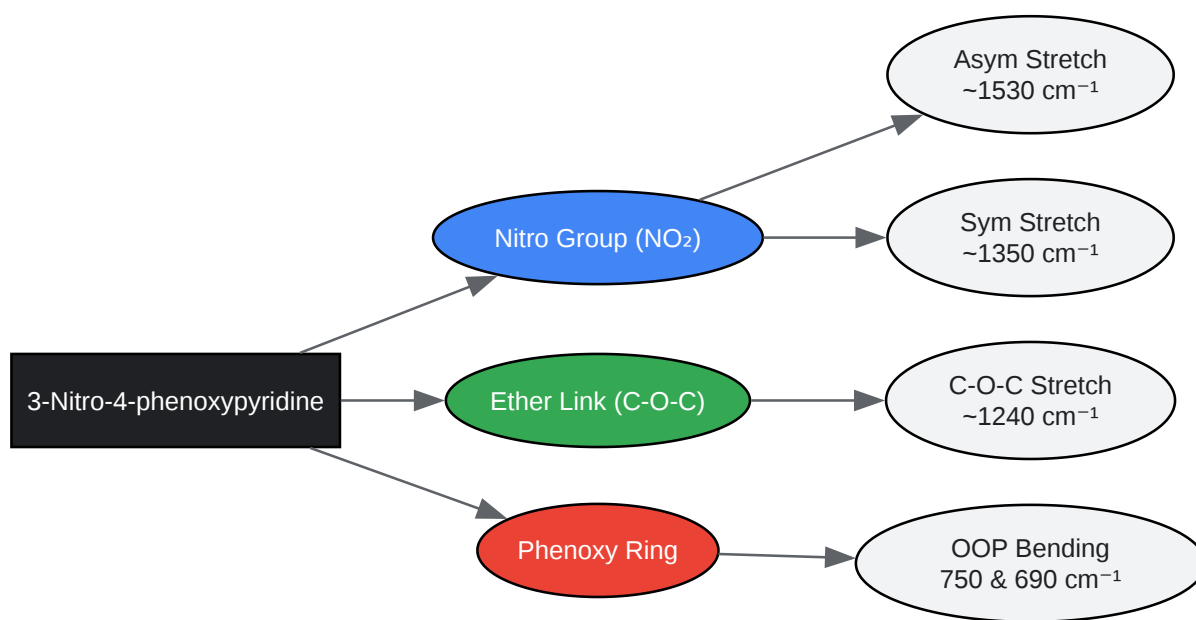

[Click to download full resolution via product page](#)

Caption: Mapping functional groups to diagnostic IR spectral bands.

References

- Vibrational Spectroscopic and Structural Investigations of 2-Amino-6-Methoxy-3-Nitropyridine: A DFT Approach. Source: Redalyc.org [\[Link\]](#) (Provides foundational DFT and experimental data for nitropyridine/ether analogues).
- Structural, Spectroscopic Characterization and Docking Study of 4-Amino-3-Nitropyridine. Source: ResearchGate [\[Link\]](#) (Validates nitro group band assignments in the 3-position of the pyridine ring).
- 2-(4-Methoxyphenoxy)-3-nitropyridine. Source: PubMed Central (PMC) [\[Link\]](#) (Direct structural analogue characterization, confirming the phenoxy-nitropyridine scaffold properties).
- Nitropyridines: Synthesis and Reactions. Source: ResearchGate [\[Link\]](#) (Overview of the synthetic pathway and mechanism for 3-nitropyridine derivatives).
- To cite this document: BenchChem. [\[IR Spectroscopy Characterization of 3-Nitro-4-phenoxy pyridine: A Comparative Technical Guide\]](#). BenchChem, [2026]. [\[Online PDF\]](#).

Available at: [<https://www.benchchem.com/product/b8759688/docs#ir-spectroscopy-characterization-of-3-nitro-4-phenoxy-pyridine-a-comparative-technical-guide>]

Disclaimer & Data Validity:

The information provided in this document is for Research Use Only (RUO) and is strictly not intended for diagnostic or therapeutic procedures. While BenchChem strives to provide accurate protocols, we make no warranties, express or implied, regarding the fitness of this product for every specific experimental setup.

Technical Support: The protocols provided are for reference purposes. Unsure if this reagent suits your experiment?

Need Industrial/Bulk Grade? [Request Custom Synthesis Quote](#)

BenchChem

Our mission is to be the trusted global source of essential and advanced chemicals, empowering scientists and researchers to drive progress in science and industry.

Contact

Address: 3281 E Guasti Rd
Ontario, CA 91761, United States
Phone: (601) 213-4426
Email: info@benchchem.com

[Contact our Ph.D. Support Team for a compatibility check](#)