

# Technical Guide: Physical Properties & Engineering of 4-Substituted Biphenyl Esters

**Author:** BenchChem Technical Support Team. **Date:** April 2026

## Compound of Interest

Compound Name: *4-Methyl-4'-acetoxybiphenyl*

Cat. No.: *B8758356*

[Get Quote](#)

## Executive Summary: The Biphenyl Ester Scaffold

The 4-substituted biphenyl ester moiety represents a "privileged structure" at the intersection of soft matter physics and medicinal chemistry. In material science, this scaffold is the archetype of the mesogen—the rigid core responsible for liquid crystalline (LC) behavior. In drug discovery, it serves as a lipophilic pharmacophore, critical for modulating membrane permeability and receptor binding affinity (e.g., in neutral endopeptidase inhibitors and NSAID prodrugs).

This guide moves beyond basic characterization to explore the structure-property relationships (SPR) that dictate how substitution at the 4-position controls thermal stability, phase transitions, and bioavailability.

## Molecular Architecture & Structure-Property Relationships (SPR)

The biphenyl ester core derives its utility from its anisotropic geometry. The rigid biphenyl unit provides the "hard" core, while the ester linkage introduces a dipole and a degree of flexibility.

## The 4-Substituent Effect

The substituent at the 4-position (

) acts as the primary tuning knob for physical properties.

Substituent Type	Example	Electronic Effect	Physical Consequence	Application
Electron Withdrawing	$\text{C}_6\text{H}_4\text{X}$	Increases longitudinal dipole moment ( $\mu$ )	Increases clearing point ( $T_{cl}$ )	
Electron Donating	$\text{C}_6\text{H}_4\text{X}$	Increases polarizability; adds steric bulk	Lowers melting point; induces Smectic phases (layered ordering).	Phase change materials
Bulky/Branched	$\text{C}_6\text{H}_4\text{X}$	Steric hindrance	Disrupts packing; lowers clearing point; increases solubility.	Drug solubility enhancement

## The "Odd-Even" Effect in Phase Transitions

For 4'-n-alkoxybiphenyl-4-carboxylates, the length of the alkyl chain (

) dictates the phase transition temperatures.

- Odd

: Lower clearing points due to lower entropic gain upon isotropization.

- Even

: Higher clearing points; more efficient packing in the crystalline state.

---

“

*Technical Insight: In drug development, this same packing efficiency correlates with solubility. An "odd" chain length ester prodrug often exhibits higher solubility in lipid formulations than its "even" homologue due to a lower crystal lattice energy.*

---

## Physical Data: Phase Behavior & Thermal Stability[2][3][4]

The following data summarizes the mesomorphic behavior of 4'-n-alkoxybiphenyl-4-carboxylic acid esters. Note the emergence of the Smectic phase as the chain lengthens.[1][2]

Table 1: Phase Transition Temperatures (

C) Key: Cr = Crystalline, N = Nematic, Sm = Smectic, I = Isotropic

Chain Length ( )	Melting Point (Cr N/Sm)	Clearing Point (N/Sm I)	Phase Sequence
(Methoxy)	108.0	125.5	Cr N I
(Ethoxy)	115.0	148.0	Cr N I
(Pentoxy)	120.5	155.0	Cr Sm N I
(Octyloxy)	102.0	162.5	Cr Sm I
(Decyloxy)	98.5	158.0	Cr Sm I

Data synthesized from Gray et al. and homologous series trends [1, 2].

## Thermal Stability

Biphenyl esters exhibit high thermal stability up to ~300

C due to the conjugation of the biphenyl system. However, the ester bond is the "weak link," susceptible to hydrolysis in acidic/basic aqueous environments—a feature exploited in prodrug design for controlled release.

## Experimental Protocols

### Synthesis: The Acid Chloride Route (Robust)

While DCC/DMAP coupling is common, the Acid Chloride method is preferred for 4-substituted biphenyls to avoid urea byproducts which are difficult to remove from liquid crystals.

Protocol: Synthesis of 4-Cyanophenyl 4'-pentylbiphenyl-4-carboxylate

- Activation:
  - Charge a flame-dried RBF with 4'-pentylbiphenyl-4-carboxylic acid (1.0 equiv).
  - Add excess Thionyl Chloride ( ) (5.0 equiv) and a catalytic drop of DMF.
  - Reflux at 80 C for 3 hours (monitor gas evolution).
  - Critical Step: Distill off excess completely under vacuum. Residual will degrade the phenol in the next step.
- Esterification:
  - Dissolve the resulting acid chloride residue in dry Dichloromethane (DCM).
  - Add 4-Cyanophenol (1.1 equiv) and Triethylamine ( ) (1.2 equiv) at 0 C.

- Stir at RT for 12 hours.
- Purification (Self-Validating):
  - Wash organic layer with 1M HCl (removes amine), then 1M NaOH (removes unreacted phenol).
  - Recrystallize from Ethanol/Hexane (1:4).
  - Validation: The product must show a sharp melting point (range < 1 C). A broad range indicates oligomer formation or trapped solvent.

## Visualization of Synthesis Workflow

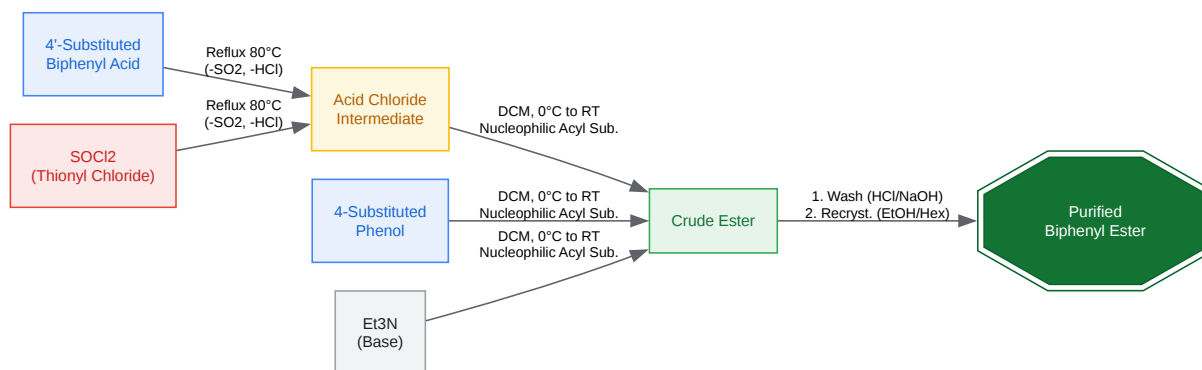

[Click to download full resolution via product page](#)

Figure 1: Step-by-step synthesis of biphenyl esters via the Acid Chloride method, ensuring removal of reactive byproducts.

## Characterization: The Self-Validating Loop

To ensure scientific integrity, characterization must confirm both chemical purity and phase behavior.

## Differential Scanning Calorimetry (DSC)

DSC is the gold standard for identifying mesophases.

- Protocol: Cycle the sample (Heat/Cool) at 10 C/min.
- Interpretation:
  - First Peak: Crystal  
Liquid Crystal (Melting Point).[\[3\]](#)
  - Second Peak: Liquid Crystal  
Isotropic Liquid (Clearing Point).
  - Hysteresis: A shift in transition temps between heating and cooling cycles indicates supercooling, common in smectic phases.

## Polarized Optical Microscopy (POM)

Visual confirmation of the phase texture is required to distinguish Nematic from Smectic phases.

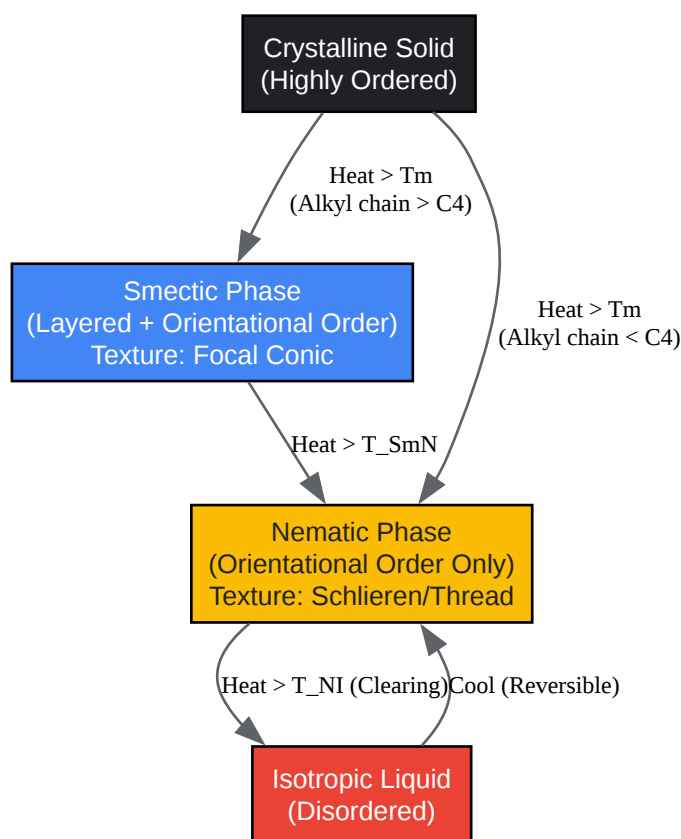

[Click to download full resolution via product page](#)

Figure 2: Phase transition logic flow. The path depends heavily on the 4-alkoxy chain length.

## Applications in Drug Development & Delivery

While often associated with displays, biphenyl esters are critical in pharma.[4]

### Prodrug Strategies

The biphenyl ester linkage is cleaved by plasma esterases.

- Problem: A parent drug (e.g., a biphenyl acetic acid NSAID) has poor oral bioavailability due to high polarity (low LogP).
- Solution: Esterification at the 4-position with a short alkyl chain increases LogP, facilitating passive diffusion through the intestinal membrane. Once in the plasma, esterases hydrolyze the bond, releasing the active acid [3].

## Scaffold Rigidity in Inhibitor Design

In inhibitors for enzymes like Sulfatase-2 or Neutral Endopeptidase, the biphenyl core provides a rigid spacer that positions pharmacophores (e.g., sulfamates or carboxylates) at precise distances to bridge hydrophobic pockets in the active site [4]. The 4-ester group often mimics the transition state of peptide hydrolysis.

## References

- Gray, G. W., Hartley, J. B., & Jones, B. (1955). Mesomorphism and Chemical Constitution.[5] Part V. The Mesomorphic Properties of the 4'-n-Alkoxydiphenyl-4-carboxylic Acids and their Simple Alkyl Esters. Journal of the Chemical Society.[3] [Link](#)
- Imrie, C. T., et al. (1993). Synthesis and Characterization of Liquid Crystalline Biphenyl Esters. Liquid Crystals.
- BenchChem. (2025).[4][6] Synthesis of Substituted Biphenyls and Applications in Drug Development. Application Notes. [Link](#)
- Taylor, S. D., et al. (2013). Design and synthesis of biphenyl and biphenyl ether inhibitors of sulfatases. PMC - NIH. [Link](#)
- NIST Chemistry WebBook. (2023). Biphenyl Phase Change Data. National Institute of Standards and Technology. [Link](#)

### Need Custom Synthesis?

BenchChem offers custom synthesis for rare earth carbides and specific isotopic labeling.

Email: [info@benchchem.com](mailto:info@benchchem.com) or [Request Quote Online](#).

## Sources

- 1. Mesomorphism and chemical constitution. Part V. The mesomorphic properties of the 4'-n-alkoxydiphenyl-4-carboxylic acids and their simple alkyl esters - Journal of the Chemical Society (Resumed) (RSC Publishing) [[pubs.rsc.org](https://pubs.rsc.org)]
- 2. [sciforum.net](https://sciforum.net) [[sciforum.net](https://sciforum.net)]

- [3. tandfonline.com](https://tandfonline.com) [tandfonline.com]
- [4. pdf.benchchem.com](https://pdf.benchchem.com) [pdf.benchchem.com]
- [5. pdfs.semanticscholar.org](https://pdfs.semanticscholar.org) [pdfs.semanticscholar.org]
- [6. mdpi.com](https://mdpi.com) [mdpi.com]
- To cite this document: BenchChem. [Technical Guide: Physical Properties & Engineering of 4-Substituted Biphenyl Esters]. BenchChem, [2026]. [Online PDF]. Available at: [<https://www.benchchem.com/product/b8758356/docs#technical-guide-physical-properties-engineering-of-4-substituted-biphenyl-esters>]

---

### Disclaimer & Data Validity:

The information provided in this document is for Research Use Only (RUO) and is strictly not intended for diagnostic or therapeutic procedures. While BenchChem strives to provide accurate protocols, we make no warranties, express or implied, regarding the fitness of this product for every specific experimental setup.

**Technical Support:** The protocols provided are for reference purposes. Unsure if this reagent suits your experiment?

**Need Industrial/Bulk Grade?** [Request Custom Synthesis Quote](#)

## BenchChem

Our mission is to be the trusted global source of essential and advanced chemicals, empowering scientists and researchers to drive progress in science and industry.

### Contact

Address: 3281 E Guasti Rd  
Ontario, CA 91761, United States  
Phone: (601) 213-4426  
Email: [info@benchchem.com](mailto:info@benchchem.com)

[Contact our Ph.D. Support Team for a compatibility check](#)

