

# Benchmarking 3-Methoxycinnamaldehyde: A Comparative Performance Guide Against Commercial Standards

**Author:** BenchChem Technical Support Team. **Date:** April 2026

## Compound of Interest

Compound Name: 2-Propenal, 3-(3-methoxyphenyl)-,  
(2E)-

Cat. No.: B8757716

[Get Quote](#)

For Researchers, Scientists, and Drug Development Professionals

In the landscape of natural product-derived therapeutic agents, cinnamaldehyde and its analogs have garnered significant attention for their diverse pharmacological activities. This guide provides an in-depth technical comparison of 3-methoxycinnamaldehyde's performance against established commercial standards in the key therapeutic areas of inflammation and cancer. By synthesizing available preclinical data and outlining robust experimental protocols, this document serves as a critical resource for researchers seeking to evaluate the potential of this promising compound.

## Section 1: Anti-Inflammatory Performance

Chronic inflammation is a key pathological driver of numerous diseases. The anti-inflammatory potential of 3-methoxycinnamaldehyde is primarily attributed to its ability to modulate key signaling pathways, most notably the NF- $\kappa$ B pathway, and inhibit the production of pro-inflammatory mediators.

## Mechanism of Action: Inhibition of the NF- $\kappa$ B Signaling Pathway

The Nuclear Factor-kappa B (NF- $\kappa$ B) signaling cascade is a cornerstone of the inflammatory response, regulating the expression of a plethora of pro-inflammatory genes. Cinnamaldehyde and its derivatives, including 3-methoxycinnamaldehyde, have been shown to inhibit NF- $\kappa$ B activation. The  $\alpha,\beta$ -unsaturated aldehyde moiety in their structure is thought to act as a Michael acceptor, enabling covalent modification of key proteins in the NF- $\kappa$ B pathway.

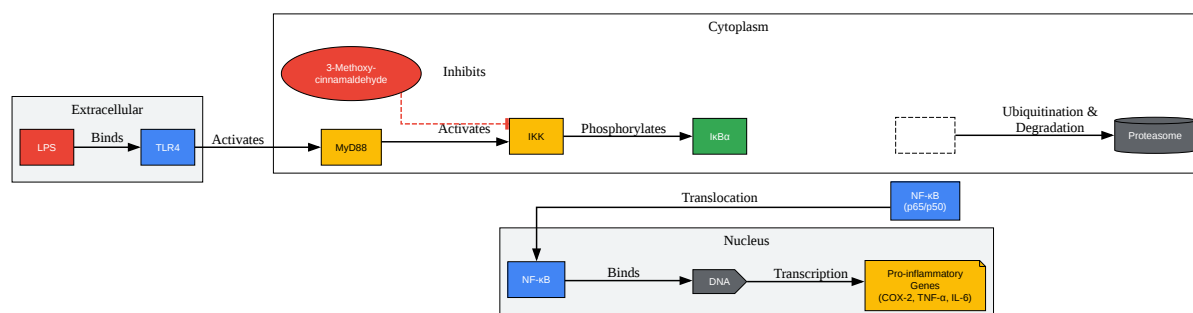

[Click to download full resolution via product page](#)

**Figure 1:** Inhibition of the NF- $\kappa$ B signaling pathway by 3-methoxycinnamaldehyde.

## Benchmarking Against Commercial Anti-Inflammatory Drugs

To contextualize the anti-inflammatory potency of 3-methoxycinnamaldehyde, we compare its performance with two widely used commercial standards: Dexamethasone, a potent corticosteroid, and Celecoxib, a selective COX-2 inhibitor.

Table 1: Comparative Anti-Inflammatory Activity (IC50 Values)

Compound	Assay	Cell Line/System	IC50 ( $\mu\text{M}$ )	Reference(s)
o-Methoxycinnamaldehyde	Nitric Oxide (NO) Production	RAW 264.7 Macrophages	$35 \pm 9$	[1]
trans-Cinnamaldehyde	Nitric Oxide (NO) Production	RAW 264.7 Macrophages	$55 \pm 9$	[1]
Dexamethasone	Nitric Oxide (NO) Production	RAW 264.7 Macrophages	$\sim 34.6 \mu\text{g/mL}$ ( $\sim 88 \mu\text{M}$ )	[2]
o-Methoxycinnamaldehyde	TNF- $\alpha$ Production	RAW 264.7 Macrophages	$78 \pm 16$	[1]
trans-Cinnamaldehyde	TNF- $\alpha$ Production	RAW 264.7 Macrophages	$63 \pm 9$	[1]
Celecoxib	COX-2 Inhibition (Human)	In vitro enzyme assay	0.04 - 0.05	[3][4][5]
Celecoxib	COX-1 Inhibition (Human)	In vitro enzyme assay	15	[3][4]

Note: IC50 values can vary between studies due to different experimental conditions. Direct head-to-head comparisons in the same study are ideal for definitive conclusions. Data for o-methoxycinnamaldehyde is presented as a close analog to 3-methoxycinnamaldehyde.

## Section 2: Anticancer Performance

The anticancer potential of 3-methoxycinnamaldehyde and its parent compounds lies in their ability to induce apoptosis (programmed cell death) and inhibit the proliferation of various

cancer cell lines.

## **Mechanism of Action: Induction of Apoptosis**

Cinnamaldehyde derivatives have been shown to induce apoptosis through multiple mechanisms, including the generation of reactive oxygen species (ROS), disruption of mitochondrial membrane potential, and activation of caspase cascades. These events ultimately lead to the systematic dismantling of the cancer cell.

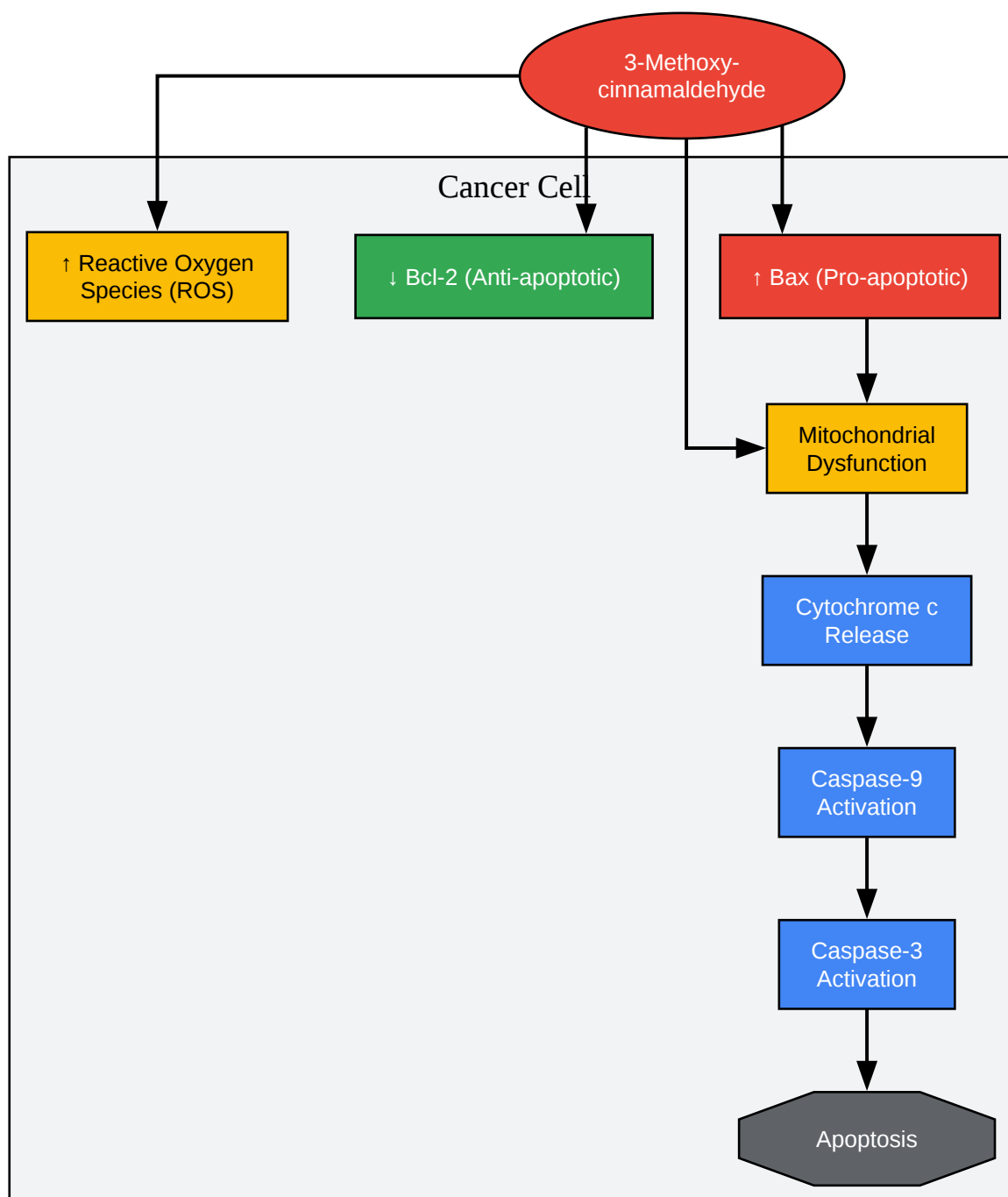

[Click to download full resolution via product page](#)

**Figure 2:** Simplified pathway of apoptosis induction by 3-methoxycinnamaldehyde.

## Benchmarking Against Commercial Anticancer Drugs

The cytotoxic and pro-apoptotic effects of 3-methoxycinnamaldehyde are benchmarked against two cornerstone chemotherapeutic agents: Doxorubicin, a topoisomerase inhibitor, and Paclitaxel, a microtubule-stabilizing agent.

Table 2: Comparative Anticancer Activity (IC50 Values)

Compound	Cell Line	Cancer Type	IC50 ( $\mu\text{M}$ )	Reference(s)
4-Methoxycinnamaldehyde	C-33A	Cervical Cancer	110	[6]
trans-Cinnamaldehyde	U87MG	Glioblastoma	11.6 $\mu\text{g}/\text{mL}$ (~87.8)	[7]
trans-Cinnamaldehyde	MCF-7	Breast Cancer	58 $\mu\text{g}/\text{mL}$ (~439) for 24h	[6]
Doxorubicin	U87MG	Glioblastoma	5 $\mu\text{g}/\text{mL}$ (~9.2)	[7]
Doxorubicin	MCF-7	Breast Cancer	0.4 - 2.5	[8][9]
Paclitaxel	HeLa	Cervical Cancer	0.005 - 0.01	[10]

Note: As with the anti-inflammatory data, direct comparison of IC50 values should be approached with caution due to inter-study variability. Data for 4-methoxycinnamaldehyde is presented as a close analog.

## Section 3: Experimental Protocols

To ensure scientific rigor and reproducibility, this section provides detailed, step-by-step methodologies for the key in vitro assays discussed in this guide.

### Anti-Inflammatory Assays

This assay quantitatively measures the activation of the NF- $\kappa$ B transcription factor.

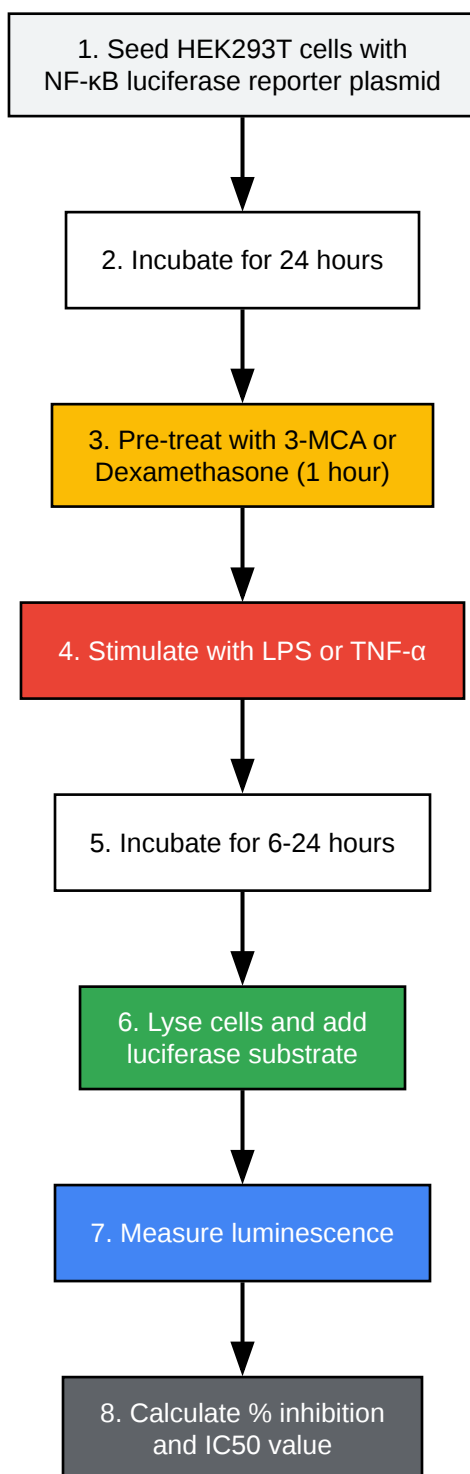

[Click to download full resolution via product page](#)

**Figure 3:** Experimental workflow for the NF-κB luciferase reporter assay.

Protocol:

- **Cell Culture and Transfection:** Culture HEK293T cells and transfect with a luciferase reporter plasmid containing NF- $\kappa$ B response elements.
- **Cell Seeding:** Seed the transfected cells into a 96-well plate and allow them to adhere overnight.
- **Compound Treatment:** Pre-treat the cells with various concentrations of 3-methoxycinnamaldehyde or the commercial standard (e.g., Dexamethasone) for 1 hour.
- **Stimulation:** Induce NF- $\kappa$ B activation by adding an appropriate stimulus, such as Lipopolysaccharide (LPS) or Tumor Necrosis Factor-alpha (TNF- $\alpha$ ).
- **Incubation:** Incubate the plate for 6-24 hours to allow for luciferase gene expression.
- **Lysis and Substrate Addition:** Lyse the cells and add a luciferase substrate according to the manufacturer's protocol.
- **Luminescence Measurement:** Measure the luminescence using a plate reader.
- **Data Analysis:** Normalize the data and calculate the half-maximal inhibitory concentration (IC<sub>50</sub>).

This assay determines the direct inhibitory effect of a compound on the cyclooxygenase-2 (COX-2) enzyme.

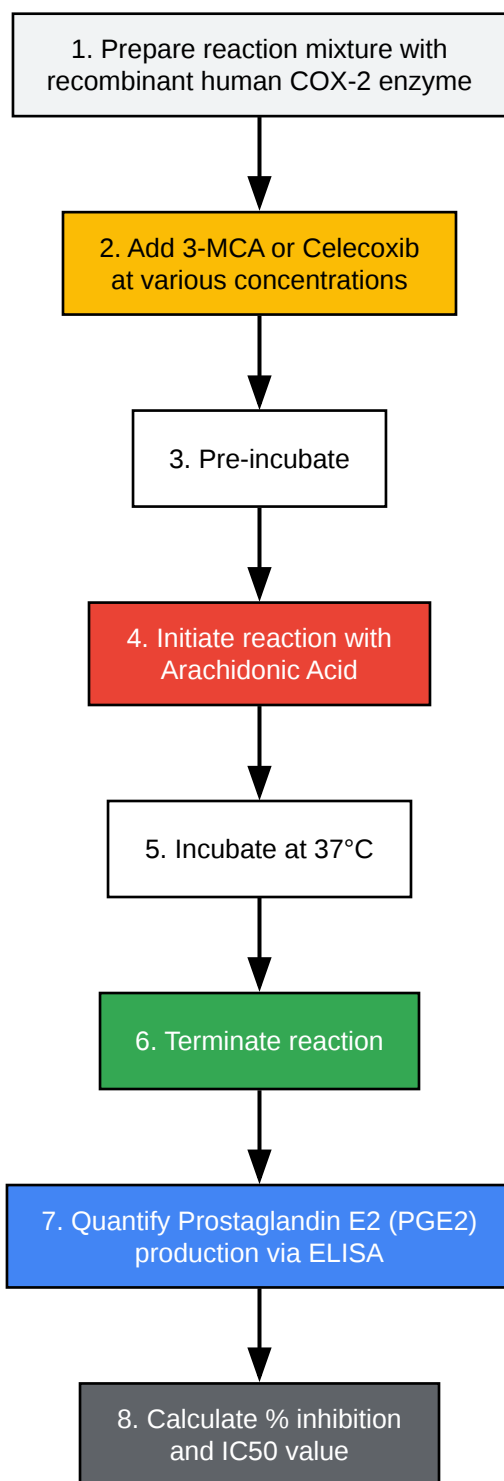

[Click to download full resolution via product page](#)

**Figure 4:** Experimental workflow for the COX-2 inhibition assay.

Protocol:

- Reagent Preparation: Prepare a reaction buffer containing recombinant human COX-2 enzyme.
- Compound Addition: Add various concentrations of 3-methoxycinnamaldehyde or the commercial standard (Celecoxib) to the reaction mixture.
- Pre-incubation: Pre-incubate the enzyme with the test compounds.
- Reaction Initiation: Initiate the enzymatic reaction by adding the substrate, arachidonic acid.
- Incubation: Incubate the reaction at 37°C for a specified time.
- Reaction Termination: Stop the reaction.
- Quantification: Measure the amount of Prostaglandin E2 (PGE2) produced using an ELISA kit.[\[3\]](#)
- Data Analysis: Calculate the percent inhibition and determine the IC50 value.

## Anticancer Assays

The MTT assay is a colorimetric assay for assessing cell metabolic activity, which serves as an indicator of cell viability, proliferation, and cytotoxicity.[\[9\]](#)

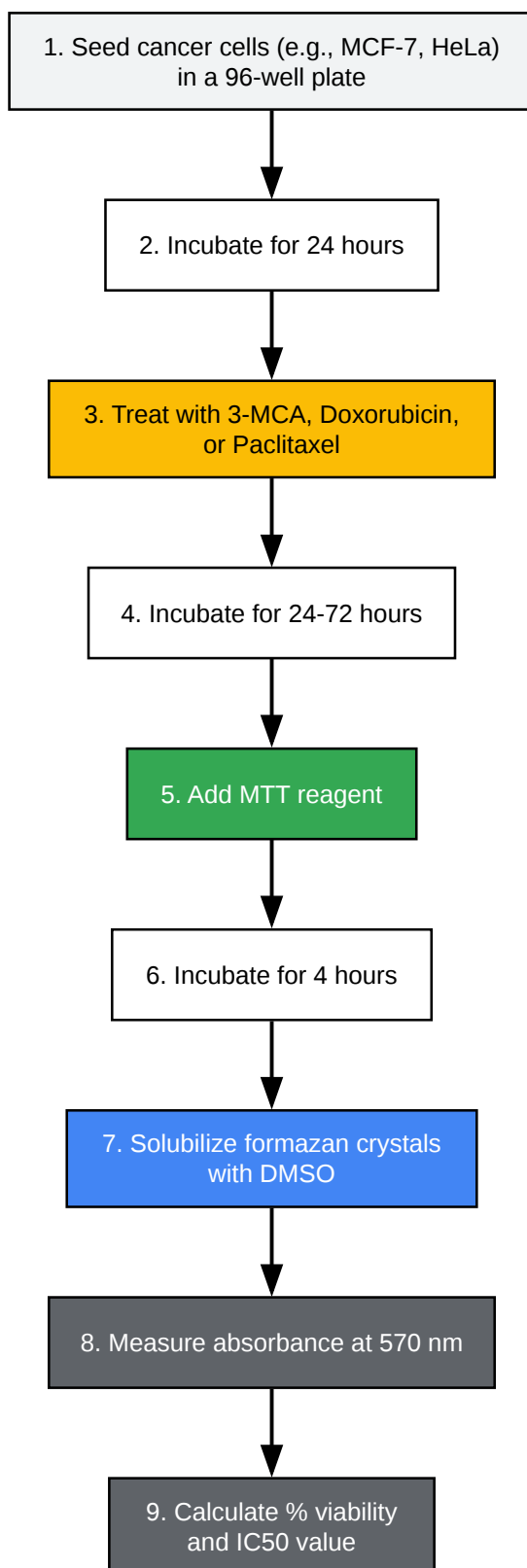

[Click to download full resolution via product page](#)

**Figure 5:** Experimental workflow for the MTT cell viability assay.

## Protocol:

- Cell Seeding: Seed cancer cells (e.g., MCF-7 for breast cancer, HeLa for cervical cancer) in a 96-well plate.[5][11]
- Incubation: Allow cells to attach and grow for 24 hours.
- Treatment: Treat the cells with various concentrations of 3-methoxycinnamaldehyde and the commercial standards (Doxorubicin, Paclitaxel).[12]
- Incubation: Incubate for 24, 48, or 72 hours.
- MTT Addition: Add MTT solution to each well and incubate for 4 hours, allowing viable cells to form formazan crystals.[9]
- Solubilization: Dissolve the formazan crystals with a solubilizing agent like DMSO.
- Absorbance Measurement: Read the absorbance at 570 nm using a microplate reader.
- Data Analysis: Calculate the percentage of cell viability relative to untreated controls and determine the IC50 values.

This flow cytometry-based assay distinguishes between viable, early apoptotic, late apoptotic, and necrotic cells.

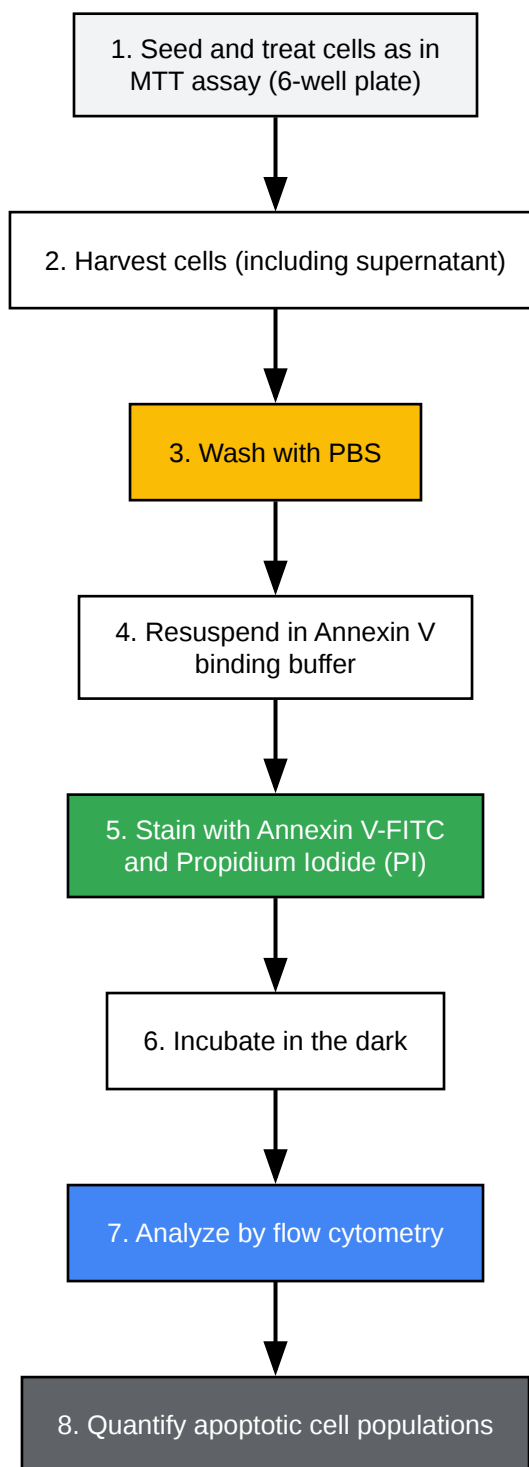

[Click to download full resolution via product page](#)

**Figure 6:** Experimental workflow for the Annexin V/PI apoptosis assay.

Protocol:

- Cell Treatment: Seed and treat cells with 3-methoxycinnamaldehyde and commercial standards in 6-well plates as described for the viability assay.
- Cell Harvesting: Collect both adherent and floating cells.
- Washing: Wash the cells with cold phosphate-buffered saline (PBS).
- Resuspension: Resuspend the cells in Annexin V binding buffer.
- Staining: Add Annexin V-FITC and Propidium Iodide (PI) to the cell suspension.
- Incubation: Incubate the cells in the dark at room temperature.
- Flow Cytometry: Analyze the stained cells using a flow cytometer.
- Data Analysis: Quantify the percentage of cells in each quadrant (viable, early apoptotic, late apoptotic, and necrotic).

## Section 4: Conclusion and Future Directions

The available data suggests that 3-methoxycinnamaldehyde and its close analogs exhibit promising anti-inflammatory and anticancer properties in vitro. Their potency, in some cases, appears to be comparable to or in a similar order of magnitude as established commercial drugs. However, it is crucial to acknowledge that direct, head-to-head comparative studies are limited. Future research should focus on conducting such direct comparisons under standardized conditions to definitively establish the therapeutic potential of 3-methoxycinnamaldehyde. Further investigations into its in vivo efficacy, safety profile, and pharmacokinetic properties are also warranted to pave the way for potential clinical applications.

## References

- Doxorubicin induces drug resistance and expression of the novel CD44st via NF- $\kappa$ B in human breast cancer MCF-7 cells - Spandidos Publications. (2014, April 7). Retrieved from [\[Link\]](#)
- Different Doxorubicin Sensitivity Across Various Human Cancer Cell Lines - Trends in Sciences. (2024, October 20). Retrieved from [\[Link\]](#)

- IC50 values for different times of paclitaxel intervention in Hela, Hela/Taxol cells. Retrieved from [\[Link\]](#)
- Measurement of cyclooxygenase inhibition using liquid chromatography-tandem mass spectrometry - PMC. Retrieved from [\[Link\]](#)
- MCF-7 Resistant Doxorubicin are Characterized by Lamellapodia, Strong Adhesion on Substrate and P-gp. Retrieved from [\[Link\]](#)
- Anticancer Potential and Molecular Mechanisms of Cinnamaldehyde and Its Congeners Present in the Cinnamon Plant - MDPI. (2023, March 30). Retrieved from [\[Link\]](#)
- IC50 in doxorubicin-resistant MCF-7 cell lines. | Download Table - ResearchGate. Retrieved from [\[Link\]](#)
- Regulation of paclitaxel-induced programmed cell death by autophagic induction: A model for cervical cancer - PMC. Retrieved from [\[Link\]](#)
- Increasing the cytotoxicity of doxorubicin in breast cancer MCF-7 cells with multidrug resistance using a mesoporous silica nanoparticle drug delivery system - PMC. Retrieved from [\[Link\]](#)
- Virtual Screening for Finding Novel COX-2 Inhibitors as Antitumor Agents. (2012, September 20). Retrieved from [\[Link\]](#)
- Evaluation of the cytotoxic and apoptogenic effects of cinnamaldehyde on U87MG cells alone and in combination with doxorubicin - PMC. (2020, February 20). Retrieved from [\[Link\]](#)
- Dexamethasone effect on NO release. Quantification of NO produced by... - ResearchGate. Retrieved from [\[Link\]](#)
- Generating Paclitaxel-Resistant in Cervical Cancer HeLa Cell Line | Bashari. Retrieved from [\[Link\]](#)
- Cytotoxic studies of paclitaxel (Taxol) in human tumour cell lines - PubMed. Retrieved from [\[Link\]](#)

- Is there anyone that has found an accurate IC50 for Paclitaxel on HeLa cells using an MTT cell viability assay? | ResearchGate. (2023, October 30). Retrieved from [\[Link\]](#)
- Design, synthesis, and in silico docking studies of novel cinnamaldehyde–chalcone derivatives with anti-cancer potential and i. (2025, August 27). Retrieved from [\[Link\]](#)
- Cinnamaldehyde and Doxorubicin Co-Loaded Graphene Oxide Wrapped Mesoporous Silica Nanoparticles for Enhanced MCF-7 Cell Apoptosis - PMC. Retrieved from [\[Link\]](#)
- Dexamethasone effects on NO production. Quantification of NO produced... - ResearchGate. Retrieved from [\[Link\]](#)
- $\alpha$ -Hexylcinnamaldehyde Synergistically Increases Doxorubicin Cytotoxicity Towards Human Cancer Cell Lines | Anticancer Research. (2016, July 15). Retrieved from [\[Link\]](#)
- Anti-inflammatory activity of cinnamon (*C. zeylanicum* and *C. cassia*) extracts - identification of E-cinnamaldehyde and o-methoxy cinnamaldehyde as the most potent bioactive compounds - PubMed. Retrieved from [\[Link\]](#)
- Anti-inflammatory activity of cinnamon (*C. zeylanicum* and *C. cassia*) extracts - Identification of E-cinnamaldehyde and o-methoxy cinnamaldehyde as the most potent bioactive compounds - ResearchGate. Retrieved from [\[Link\]](#)
- IC50 Values for Paclitaxel and Analogs in Cytotoxicity Assays with Breast Cancer Cell Lines. (2015, June 7). Retrieved from [\[Link\]](#)
- Preparation, Spectral Characterization and Anticancer Potential of Cinnamic Esters - Semantic Scholar. (2021, June 11). Retrieved from [\[Link\]](#)
- Appraisal of Cinnamaldehyde Analogs as Dual-Acting Antibiofilm and Anthelmintic Agents. (2022, March 15). Retrieved from [\[Link\]](#)
- Insights into Anti-Inflammatory Activity and Internalization Pathway of Onion Peel-Derived Gold Nano Bioconjugates in RAW 264.7 Macrophages | ACS Omega. (2022, February 22). Retrieved from [\[Link\]](#)
- IC50 Values for Paclitaxel and Analogs in Cytotoxicity | Open-i - NIH. Retrieved from [\[Link\]](#)

- Dexamethasone inhibits IL-1 beta gene expression in LPS-stimulated RAW 264.7 cells by blocking NF-kappa B/Rel and AP-1 activation - PubMed. (2000, July 20). Retrieved from [\[Link\]](#)
- Synthesis, Characterization, Antioxidant, and Anticancer Activity against Colon Cancer Cells of Some Cinnamaldehyde-Based Chalcone Derivatives - MDPI. (2024, February 12). Retrieved from [\[Link\]](#)
- IC50 Values for Paclitaxel and Analogs in Cytotoxicity Assays with... - ResearchGate. Retrieved from [\[Link\]](#)
- Synthesis, Characterization, Antioxidant, and Anticancer Activity against Colon Cancer Cells of Some Cinnamaldehyde-Based Chalcone Derivatives - Semantic Scholar. (2024, February 12). Retrieved from [\[Link\]](#)
- Comparison of anticancer activity (IC50 values) between active compounds and PTX. (PTX - ResearchGate. Retrieved from [\[Link\]](#)
- Cinnamaldehyde derivatives inhibit degranulation and inflammatory mediator production in rat basophilic leukemia cells. | Semantic Scholar. Retrieved from [\[Link\]](#)
- Design and Development of COX-II Inhibitors: Current Scenario and Future Perspective. Retrieved from [\[Link\]](#)
- (PDF) Ceylon cinnamon and its major compound Cinnamaldehyde can limit overshooting inflammatory signaling and angiogenesis in vitro: implications for COVID-19 treatment - ResearchGate. (2026, March 2). Retrieved from [\[Link\]](#)
- IC50 values of antiproliferative activity of cinnamaldehyde, cinnamic... | Download Scientific Diagram - ResearchGate. Retrieved from [\[Link\]](#)
- NO production in LPS-induced RAW264.7. NEG: untreated cell group; DEX:... | Download Scientific Diagram - ResearchGate. Retrieved from [\[Link\]](#)
- Cinnamaldehyde inhibits pro-inflammatory cytokines secretion from monocytes/macrophages through suppression of intracellular signaling - PubMed. (2008, January 15). Retrieved from [\[Link\]](#)

- Anti-inflammatory and tissue repair effect of cinnamaldehyde and nano cinnamaldehyde on gingival fibroblasts and macrophages - PMC. (2023, December 19). Retrieved from [[Link](#)]
- Evaluation of 2 celecoxib derivatives: analgesic effect and selectivity to cyclooxygenase-2/11 - AME Publishing Company. Retrieved from [[Link](#)]

### Need Custom Synthesis?

BenchChem offers custom synthesis for rare earth carbides and specific isotopic labeling.

Email: [info@benchchem.com](mailto:info@benchchem.com) or [Request Quote Online](#).

## Sources

- 1. [pdf.benchchem.com](https://pdf.benchchem.com) [[pdf.benchchem.com](https://pdf.benchchem.com)]
- 2. [researchgate.net](https://researchgate.net) [[researchgate.net](https://researchgate.net)]
- 3. [eurekaselect.com](https://eurekaselect.com) [[eurekaselect.com](https://eurekaselect.com)]
- 4. Cinnamaldehyde-Mediated Suppression of MMP-13, COX-2, and IL-6 Through MAPK and NF- $\kappa$ B Signaling Inhibition in Chondrocytes and Synoviocytes Under Inflammatory Conditions - PMC [[pmc.ncbi.nlm.nih.gov](https://pubmed.ncbi.nlm.nih.gov/)]
- 5. [journal.waocp.org](https://journal.waocp.org) [[journal.waocp.org](https://journal.waocp.org)]
- 6. [mdpi.com](https://mdpi.com) [[mdpi.com](https://mdpi.com)]
- 7. [mdpi.com](https://mdpi.com) [[mdpi.com](https://mdpi.com)]
- 8. Design, synthesis, and in silico docking studies of novel cinnamaldehyde–chalcone derivatives with anti-cancer potential and in vivo acute oral toxic ... - RSC Advances (RSC Publishing) DOI:10.1039/D5RA03706A [[pubs.rsc.org](https://pubs.rsc.org)]
- 9. [mdpi.com](https://mdpi.com) [[mdpi.com](https://mdpi.com)]
- 10. [storage.googleapis.com](https://storage.googleapis.com) [[storage.googleapis.com](https://storage.googleapis.com)]
- 11. Cinnamaldehyde: Pharmacokinetics, anticancer properties and therapeutic potential (Review) - PMC [[pmc.ncbi.nlm.nih.gov](https://pubmed.ncbi.nlm.nih.gov/)]
- 12. [researchgate.net](https://researchgate.net) [[researchgate.net](https://researchgate.net)]
- To cite this document: BenchChem. [Benchmarking 3-Methoxycinnamaldehyde: A Comparative Performance Guide Against Commercial Standards]. BenchChem, [2026]. [Online PDF]. Available at:

[<https://www.benchchem.com/product/b8757716/docs#benchmarking-3-methoxycinnamaldehyde-a-comparative-performance-guide-against-commercial-standards>]

### Disclaimer & Data Validity:

The information provided in this document is for Research Use Only (RUO) and is strictly not intended for diagnostic or therapeutic procedures. While BenchChem strives to provide accurate protocols, we make no warranties, express or implied, regarding the fitness of this product for every specific experimental setup.

**Technical Support:** The protocols provided are for reference purposes. Unsure if this reagent suits your experiment?

**Need Industrial/Bulk Grade?** [Request Custom Synthesis Quote](#)

## BenchChem

Our mission is to be the trusted global source of essential and advanced chemicals, empowering scientists and researchers to drive progress in science and industry.

### Contact

Address: 3281 E Guasti Rd  
Ontario, CA 91761, United States  
Phone: (601) 213-4426  
Email: [info@benchchem.com](mailto:info@benchchem.com)

[Contact our Ph.D. Support Team for a compatibility check](#)