

FTIR Analysis of 4-(Allyloxy)-2-hydroxybenzaldehyde: A Comprehensive Technical Guide

Author: BenchChem Technical Support Team. **Date:** April 2026

Compound of Interest

Compound Name: 4-(Allyloxy)-2-hydroxybenzaldehyde

Cat. No.: B8755843

[Get Quote](#)

Molecular Architecture & Spectroscopic Rationale

In the realm of drug development and fine chemical synthesis, **4-(Allyloxy)-2-hydroxybenzaldehyde** (often referred to as 4-allyloxysalicylaldehyde) serves as a critical scaffold for synthesizing complex coumarins, ethers, and Schiff base ligands. To effectively characterize this molecule using Fourier Transform Infrared (FTIR) spectroscopy, an analyst must first deconstruct its molecular architecture into three distinct functional zones, as these dictate the vibrational modes observed in the spectrum:

- **The Salicylaldehyde Core:** The proximity of the ortho-hydroxyl (-OH) and aldehyde (-CHO) groups forces a strong, highly stable intramolecular hydrogen bond. This interaction weakens the C=O double bond character, causing a significant red-shift (lower wavenumber) in both the carbonyl and hydroxyl stretching frequencies[1].
- **The Allyloxy Ether Linkage:** The para-substitution of the allyloxy group (-O-CH₂-CH=CH₂) introduces distinct alkyl aryl ether C-O-C stretching modes[2].

- The Terminal Alkene: The allyl tail acts as a unique spectroscopic tag, providing sharp, diagnostic out-of-plane bending modes that confirm successful allylation during synthesis without the need for immediate NMR verification.

Experimental Workflow: High-Fidelity FTIR Protocol

While traditional KBr pelleting is common, it is fundamentally flawed for molecules with critical hydrogen-bonding dynamics like **4-(Allyloxy)-2-hydroxybenzaldehyde**. KBr is highly hygroscopic; absorbed atmospheric moisture presents a broad O-H stretch around 3400 cm^{-1} , which masks the critical, endogenous intramolecular H-bonded O-H stretch of the target molecule.

Causality-Driven Choice: We mandate the use of Attenuated Total Reflectance (ATR). ATR utilizes a diamond or ZnSe crystal to measure the evanescent wave penetrating the sample, completely eliminating moisture artifacts and preserving the native hydrogen-bond network of the solid or neat liquid.

Step-by-Step ATR-FTIR Methodology

- Crystal Preparation: Clean the ATR crystal with a highly volatile, non-interfering solvent (e.g., HPLC-grade isopropanol). Allow complete evaporation.
- Background Acquisition: Collect a background spectrum of ambient air (32 scans, 4 cm^{-1} resolution) to digitally subtract atmospheric CO_2 and water vapor from the final data.
- Sample Application: Place 1–2 mg of the synthesized **4-(Allyloxy)-2-hydroxybenzaldehyde** directly onto the crystal. Apply consistent, firm pressure using the ATR anvil. Mechanistic note: Intimate optical contact is required because the evanescent wave penetrates less than 2 microns into the sample.
- Spectral Acquisition: Scan from 4000 to 400 cm^{-1} using a minimum of 32 scans to optimize the signal-to-noise ratio.
- Data Processing: Apply ATR correction algorithms to account for wavelength-dependent penetration depth (peaks at lower wavenumbers appear artificially intense in raw ATR data), followed by a baseline correction.

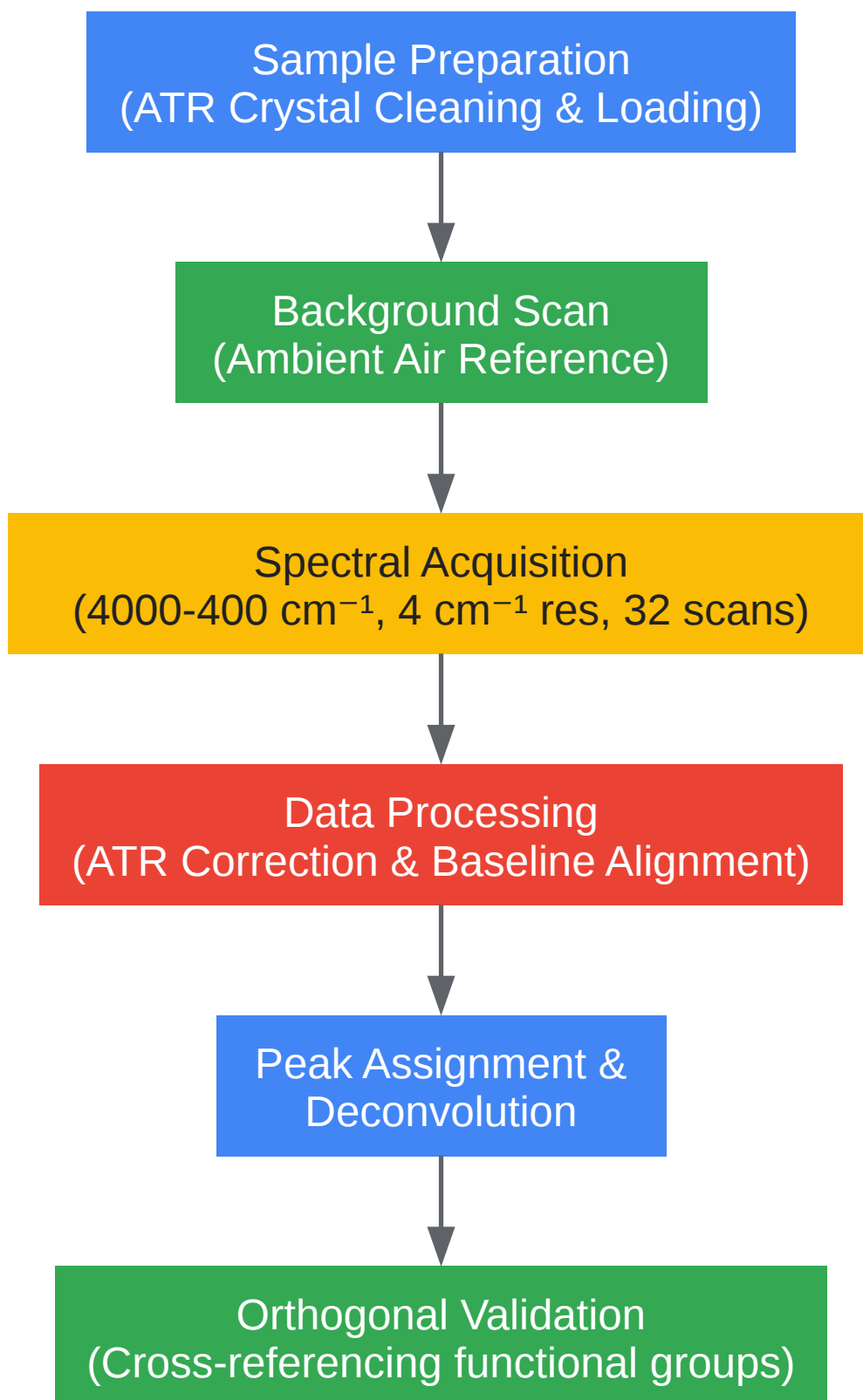

[Click to download full resolution via product page](#)

Fig 1. Step-by-step FTIR analytical workflow emphasizing self-validating spectral processing.

Spectral Deconvolution & Quantitative Assignments

The following table summarizes the quantitative data required to positively identify **4-(Allyloxy)-2-hydroxybenzaldehyde**. The assignments are grounded in established spectroscopic libraries for salicylaldehyde derivatives[3] and methoxybenzaldehyde analogs[2].

Wavenumber Region (cm ⁻¹)	Intensity	Functional Group	Vibrational Mode	Mechanistic Rationale
3100 – 3400	Broad, Med	-OH (Phenolic)	Stretching	Broadened and red-shifted due to strong intramolecular H-bonding with the ortho-aldehyde carbonyl[3].
3080	Weak	=C-H (Allyl)	Stretching	sp ² hybridized C-H stretch of the terminal alkene.
2840 & 2740	Weak	-CHO (Aldehyde)	Stretching	Fermi resonance doublet; a highly specific diagnostic marker for aldehydes[1].
1650 – 1665	Strong	C=O (Aldehyde)	Stretching	Shifted from typical ~1700 cm ⁻¹ due to conjugation with the aromatic ring and intramolecular H-bonding[1].
1645	Medium	C=C (Allyl)	Stretching	Often appears as a shoulder on the C=O peak; represents the isolated terminal double bond.
1580, 1500	Strong	C=C (Aromatic)	Stretching	Skeletal ring breathing

vibrations.

1250, 1020	Strong	C-O-C (Ether)	Asym/Sym Stretch	Confirms the alkyl aryl ether linkage at the 4-position[2].
990, 930	Strong	=CH ₂ (Allyl)	Out-of-plane bend	Critical diagnostic peaks confirming the presence of the intact allyl tail.

Mechanistic Insights: The Self-Validating System

A robust analytical protocol must be inherently self-validating. Relying on a single peak for structural confirmation is a critical error in drug development QC. In the case of **4-(Allyloxy)-2-hydroxybenzaldehyde**, the presence of one functional group's peak necessitates the presence of its corresponding secondary peaks.

- **The Aldehyde Triad:** The observation of the red-shifted C=O peak (~1660 cm⁻¹) is not enough. It must be accompanied by the Fermi resonance doublet (2840/2740 cm⁻¹)[1]. If the doublet is missing, the C=O peak likely belongs to an ester or ketone impurity. Furthermore, because the C=O is shifted due to hydrogen bonding, the broad -OH band (3100–3400 cm⁻¹) must also be present[3].
- **The Allyl Signature:** The ether C-O-C stretches (1250/1020 cm⁻¹) confirm the attachment of an oxygen-bearing group to the ring, but they do not confirm the terminal double bond[2]. The analyst must cross-reference the low-frequency "fingerprint" region for the 990 and 930 cm⁻¹ out-of-plane bending modes to validate the allyl group's integrity. If these are absent, the allyl group may have been saturated or cleaved during synthesis.

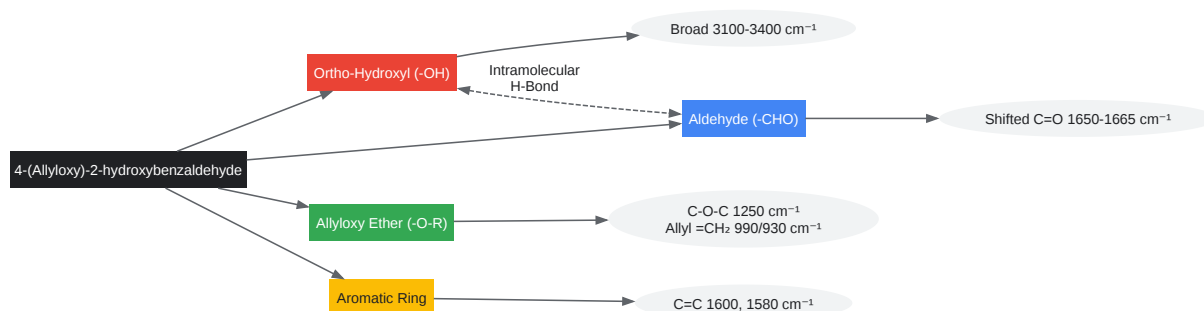

[Click to download full resolution via product page](#)

Fig 2. Logical mapping of molecular substructures to their primary FTIR spectral manifestations.

Conclusion

FTIR analysis of **4-(Allyloxy)-2-hydroxybenzaldehyde** is an exercise in understanding molecular causality. By utilizing ATR-FTIR to preserve the native hydrogen-bonded state, and by applying a self-validating interpretation matrix (cross-referencing the aldehyde triad and the allyl signature), researchers can achieve high-confidence structural verification. This protocol ensures that downstream synthetic applications utilizing this scaffold are built on a foundation of absolute chemical certainty.

References

- Arabian Journal of Chemistry Title: Structural and orthoselectivity study of 2-hydroxybenzaldehyde using spectroscopic analysis URL:[[Link](#)]
- NIST Chemistry WebBook Title: Benzaldehyde, 2-hydroxy- (Standard Reference Data) URL: [[Link](#)]
- National Center for Biotechnology Information (PubChem) Title: 2-Hydroxy-4-Methoxybenzaldehyde (CID 69600) URL:[[Link](#)]

- Frontiers in Microbiology Title: 2-Hydroxy-4-methoxybenzaldehyde, a more effective antifungal aroma... URL:[[Link](#)]

Need Custom Synthesis?

BenchChem offers custom synthesis for rare earth carbides and specific isotopic labeling.

Email: info@benchchem.com or [Request Quote Online](#).

Sources

- 1. arabjchem.org [arabjchem.org]
- 2. 2-Hydroxy-4-Methoxybenzaldehyde | C₈H₈O₃ | CID 69600 - PubChem [pubchem.ncbi.nlm.nih.gov]
- 3. Benzaldehyde, 2-hydroxy- [webbook.nist.gov]
- To cite this document: BenchChem. [FTIR Analysis of 4-(Allyloxy)-2-hydroxybenzaldehyde: A Comprehensive Technical Guide]. BenchChem, [2026]. [Online PDF]. Available at: [<https://www.benchchem.com/product/b8755843/docs#ftir-analysis-of-4-allyloxy-2-hydroxybenzaldehyde-a-comprehensive-technical-guide>]

Disclaimer & Data Validity:

The information provided in this document is for Research Use Only (RUO) and is strictly not intended for diagnostic or therapeutic procedures. While BenchChem strives to provide accurate protocols, we make no warranties, express or implied, regarding the fitness of this product for every specific experimental setup.

Technical Support: The protocols provided are for reference purposes. Unsure if this reagent suits your experiment?

Need Industrial/Bulk Grade? [Request Custom Synthesis Quote](#)

BenchChem

Our mission is to be the trusted global source of essential and advanced chemicals, empowering scientists and researchers to drive progress in science and industry.

Contact

Address: 3281 E Guasti Rd

Ontario, CA 91761, United States

Phone: (601) 213-4426

Email: info@benchchem.com

[Contact our Ph.D. Support Team for a compatibility check](#)