

# Application Note: Synthesis Protocols and Pharmacological Profiling of Scaffolds

**Author:** BenchChem Technical Support Team. **Date:** April 2026

## Compound of Interest

Compound Name: C18H13CIN2O2

Cat. No.: B8723462

[Get Quote](#)

Target Audience: Researchers, Medicinal Chemists, and Drug Development Professionals

Document Type: Advanced Technical Protocol & Mechanistic Guide

## Executive Summary

In medicinal chemistry, the molecular formula

(Exact Mass: 324.066 g/mol ) does not define a single chemical entity, but rather a highly privileged physicochemical space[1]. Molecules occupying this space frequently exhibit favorable lipophilicity (LogP ~3.3 - 3.9) and structural rigidity, making them ideal candidates for targeted receptor binding[1][2].

This application note details the synthesis and validation of two prominent

structural classes: Quinoline-based isoindolin-1-ones (antimicrobial/anticancer scaffolds) and Pyran-3-carbonitriles (anti-diabetic agents)[3][4]. Furthermore, we explore the pharmacological application of this chemical space by profiling CPYPP, a

isomer that acts as a potent inhibitor of the DOCK2 signaling pathway in immunology[5].

## Physicochemical & Pharmacological Data Summary

To establish a self-validating experimental baseline, the following table summarizes the quantitative metrics of key

isomers. Analytical validation (NMR/IR) must align with these parameters before proceeding to in vitro assays.

| Compound Class / Isomer       | Primary Biological Target | Yield (%)                  | Melting Point (°C)      | Key IR Absorptions ( , cm ) |
|-------------------------------|---------------------------|----------------------------|-------------------------|-----------------------------|
| Quinoline-Isoindolin-1-one[3] | Broad-spectrum kinase     | 67 - 74%                   | 261 - 263               | 1685 (C=O), 1613, 1510      |
| Pyran-3-carbonitrile[4]       | -glucosidase              | 48 - 55%                   | 268 - 270               | 3429 (OH), 2202 (CN)        |
| CPYPP[5]                      | DOCK2 (IC = 22.8 μM)      | N/A (Commercially sourced) | N/A (Crystalline solid) | UV/Vis : 247, 362 nm        |

## Synthetic Methodologies & Mechanistic Rationale

As a Senior Application Scientist, I emphasize that successful synthesis relies on understanding the causality of the reaction environment. The protocols below are designed to maximize atom economy and trap reactive intermediates before hydrolytic degradation can occur.

### Protocol A: One-Pot Cascade Synthesis of Quinoline-based Isoindolin-1-ones

Reference standard protocol adapted for derivatives[3].

Mechanistic Rationale: This protocol utilizes a cascade Williamson-type condensation followed by an intramolecular C-N bond cyclization. The choice of an Ethanol-Acetic Acid (10:1) solvent

system is critical; the acetic acid acts as a mild proton donor, activating the carbonyl carbon for nucleophilic attack by the amine, while simultaneously stabilizing the transitional iminium species.

#### Step-by-Step Methodology:

- **Substrate Preparation:** Charge a dry, round-bottom flask with 2.0 mmol of ethyl 6-chloro-2-(chloromethyl)quinoline-3-carboxylate.
- **Amine Addition:** Add 1.0 mmol of the corresponding aromatic amine. The stoichiometric excess of the quinoline substrate ensures complete consumption of the amine, preventing difficult downstream chromatographic separations.
- **Solvent Introduction:** Suspend the mixture in 8 mL of a pre-mixed EtOH–AcOH (10:1 v/v) solvent system.
- **Thermal Cyclization:** Attach a reflux condenser and heat the mixture to reflux (approx. 80–85°C) under an inert nitrogen atmosphere for 8 to 10 hours.
- **Reaction Monitoring:** Monitor via TLC (Hexane/EtOAc 90:10). The disappearance of the starting materials indicates the completion of the cascade cyclization.
- **Workup & Purification:** Cool the reaction to room temperature. Remove the solvent under reduced pressure. Purify the crude residue via silica gel column chromatography (Hexane/EtOAc 90:10 eluent) to afford the pure product.
- **Validation:** Confirm structure via C NMR. Look for the characteristic disappearance of the chloromethyl carbon peak and the emergence of the isoindolinone core signals.

## Protocol B: Michael Cyclization for Pyran-3-carbonitriles

Reference standard protocol for anti-diabetic

scaffolds[4].

Mechanistic Rationale: This synthesis leverages the push-pull nature of

-unsaturated carbonyl compounds. By utilizing a bidentate carbon/nitrogen nucleophile (like cyanoacetamide), the initial Michael addition is rapidly followed by an intramolecular cyclization.

Step-by-Step Methodology:

- Reagent Mixing: Combine 10 mmol of the -unsaturated precursor with 10 mmol of cyanoacetamide in a reaction vessel.
- Catalysis: Introduce a catalytic amount of a mild base (e.g., piperidine) to deprotonate the active methylene of cyanoacetamide, generating the reactive enolate.
- Reaction: Stir the mixture in 50 mL of absolute ethanol at reflux for 4-6 hours.
- Isolation: Upon completion, cool the mixture to 0°C. The pyran-3-carbonitrile derivative will precipitate. Filter the solid, wash with cold water, and recrystallize from methanol.
- Validation: IR spectroscopy is highly diagnostic here; ensure the presence of a sharp nitrile (-CN) stretch at ~2202 cm

[4].

## Pharmacological Application: DOCK2 Inhibition Pathway

To understand the biological utility of the

chemical space, we examine CPYPP, a structurally related isomer utilized heavily in immunological assays[5].

CPYPP acts as an allosteric inhibitor of Deducator of Cytokinesis 2 (DOCK2), a guanine nucleotide exchange factor (GEF). By binding to DOCK2, CPYPP prevents the exchange of GDP for GTP on the Rac GTPase. This blockade halts downstream actin cytoskeleton rearrangement, effectively terminating chemokine-induced T and B cell migration[5].

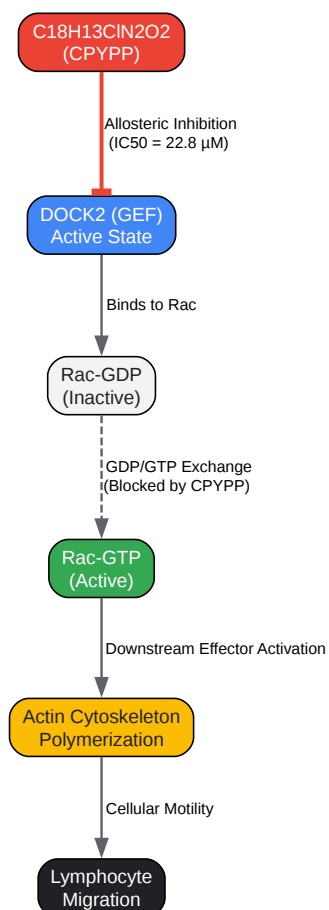

[Click to download full resolution via product page](#)

Figure 1: Mechanism of action for **C18H13CIN2O2** (CPYPP) inhibiting the DOCK2/Rac signaling axis.

## Safety and Handling Protocols

When synthesizing or handling

derivatives, strict adherence to laboratory safety protocols is mandatory.

- Toxicity: Many compounds in this class (including CPYPP) are classified as acute oral toxicants (Category 4) and skin/eye irritants (Category 2/2A)[6].
- PPE: Handling requires standard professional PPE: nitrile gloves, safety goggles, and a properly ventilated fume hood to mitigate respiratory irritation (STOT SE 3)[5][6].
- Storage: Purified compounds should be stored as crystalline solids at -20°C, purged with an inert gas (Argon/Nitrogen) to ensure multi-year stability[5].

## References

- PubChem Compound Summary for CID 135137475 National Institutes of Health (NIH)[[Link](#)]
- PubChem Compound Summary for CID 156906799 National Institutes of Health (NIH)[[Link](#)]
- A General Synthesis of Novel Quinoline-Based Isoindolin-1-one Derivatives Heterocycles / Clockss.org [[Link](#)]
- Michael Cyclization of Polarized Systems: Synthesis and in vitro Anti-Diabetic Evaluation Srce.hr [[Link](#)]
- PubChem Safety and Hazards for CID 132933455 National Institutes of Health (NIH)[[Link](#)]

### *Need Custom Synthesis?*

*BenchChem offers custom synthesis for rare earth carbides and specific isotopic labeling.*

*Email: [info@benchchem.com](mailto:info@benchchem.com) or [Request Quote Online](#).*

## Sources

- [1. US11135207, Example 24 | C18H13ClN2O2 | CID 135137475 - PubChem \[pubchem.ncbi.nlm.nih.gov\]](#)
- [2. \(3S\)-5-chloro-N-\(isoquinolin-4-yl\)-2,3-dihydro-1-benzofuran-3-carboxamide | C18H13ClN2O2 | CID 156906799 - PubChem \[pubchem.ncbi.nlm.nih.gov\]](#)
- [3. triggered.stanford.clockss.org \[triggered.stanford.clockss.org\]](#)
- [4. hrcak.srce.hr \[hrcak.srce.hr\]](#)
- [5. cdn.caymanchem.com \[cdn.caymanchem.com\]](#)
- [6. N-\(4'-chloro-\(1,1'-biphenyl\)-2-yl\)-2-hydroxypyridine-3-carboxamide | C18H13ClN2O2 | CID 132933455 - PubChem \[pubchem.ncbi.nlm.nih.gov\]](#)
- To cite this document: BenchChem. [Application Note: Synthesis Protocols and Pharmacological Profiling of Scaffolds]. BenchChem, [2026]. [Online PDF]. Available at: [\[https://www.benchchem.com/product/b8723462/docs#application-note-synthesis-protocols-and-pharmacological-profiling-of-scaffolds\]](https://www.benchchem.com/product/b8723462/docs#application-note-synthesis-protocols-and-pharmacological-profiling-of-scaffolds)

---

### Disclaimer & Data Validity:

The information provided in this document is for Research Use Only (RUO) and is strictly not intended for diagnostic or therapeutic procedures. While BenchChem strives to provide accurate protocols, we make no warranties, express or implied, regarding the fitness of this product for every specific experimental setup.

**Technical Support:** The protocols provided are for reference purposes. Unsure if this reagent suits your experiment?

**Need Industrial/Bulk Grade?** [Request Custom Synthesis Quote](#)

## BenchChem

Our mission is to be the trusted global source of essential and advanced chemicals, empowering scientists and researchers to drive progress in science and industry.

### Contact

Address: 3281 E Guasti Rd  
Ontario, CA 91761, United States  
Phone: (601) 213-4426  
Email: [info@benchchem.com](mailto:info@benchchem.com)

Contact our Ph.D. Support Team for a compatibility check