

Precision C-H Functionalization of 1-Methyl-3-phenylindole: C2-Targeting Protocols

Author: BenchChem Technical Support Team. **Date:** April 2026

Compound of Interest

Compound Name: 1-Methyl-3-phenylindole

CAS No.: 30020-98-5

Cat. No.: B8721769

[Get Quote](#)

Introduction: The Scaffold & Strategic Significance

The **1-Methyl-3-phenylindole** scaffold represents a privileged pharmacophore in medicinal chemistry, bridging the structural space between simple indoles and complex carbazoles. Its 2,3-disubstituted architecture is central to various anti-inflammatory agents (e.g., COX-2 inhibitors), anticancer therapeutics, and fluorescent probes.

For drug development professionals, the challenge lies in late-stage diversification. Traditional methods (e.g., Fischer indole synthesis or cross-coupling of pre-halogenated precursors) are step-intensive. Transition-metal-catalyzed C-H functionalization offers a direct, atom-economical alternative.^{[1][2]} However, the presence of the C3-phenyl group and the N-methyl moiety dictates a specific reactivity profile that must be navigated with precision.

Mechanistic Considerations & Regioselectivity

The regioselectivity of **1-Methyl-3-phenylindole** is governed by the interplay of electronic activation and steric blocking:

- C3 Position (Blocked): The most nucleophilic site (C3) is occupied by the phenyl ring. This naturally directs electrophilic metallation to the C2 position.
- C2 Position (Active): With C3 blocked, C2 becomes the primary site for palladium(II) and rhodium(III) activation via Concerted Metallation-Deprotonation (CMD) or electrophilic palladation.
- C4-C7 Benzenoid Ring (Passive): Functionalization here is kinetically disfavored without specific directing groups (e.g., C3-carbonyls) that are absent in this substrate.
- N-Methyl Group: Prevents N-deprotonation, eliminating the formation of indolyl anions and necessitating neutral C-H activation pathways.

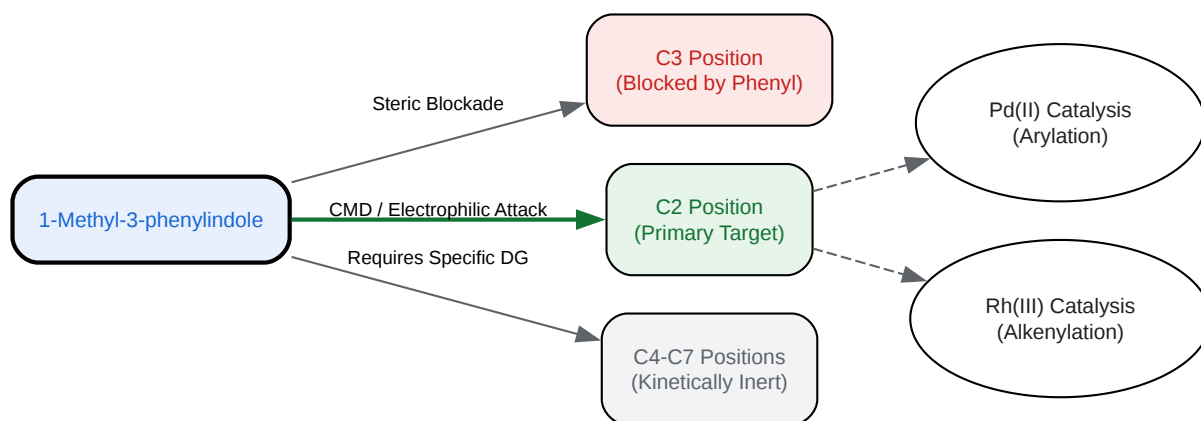

[Click to download full resolution via product page](#)

Figure 1: Regioselectivity map of **1-Methyl-3-phenylindole** highlighting the C2 position as the primary site for transition-metal catalysis.

Protocol 1: Palladium-Catalyzed C2-Arylation (Direct Arylation)[3][4]

This protocol utilizes a Pd(II)/Pd(0) catalytic cycle to couple aryl halides directly to the C2 position. Unlike standard Suzuki couplings, this does not require a C2-boronic acid; the indole itself acts as the nucleophile.

Mechanistic Insight

The reaction proceeds via a CMD mechanism. The carbonate or acetate base coordinates to the Pd(II) center, assisting in the deprotonation of the C2-H bond while simultaneously forming the Pd-C bond. The bulky phosphine ligand prevents catalyst aggregation and facilitates the oxidative addition of the aryl halide.

Experimental Conditions

Component	Reagent	Equiv/Conc.	Role
Substrate	1-Methyl-3-phenylindole	1.0 equiv	Nucleophile
Coupling Partner	Aryl Iodide (Ar-I)	1.2 - 1.5 equiv	Electrophile
Catalyst	Pd(OAc) ₂	5 mol%	Pre-catalyst
Ligand	PPh ₃ or PCy ₃	10 - 20 mol%	Stabilizes Pd species
Base	Cs ₂ CO ₃ or Ag ₂ CO ₃	2.0 equiv	Proton scavenger / CMD
Solvent	DMA or DMF	0.2 M	Polar aprotic solvent
Temp/Time	125°C	12 - 24 h	Thermal activation

Step-by-Step Protocol

- Preparation: Oven-dry a 25 mL Schlenk tube or pressure vial containing a magnetic stir bar. Allow to cool under a stream of argon.
- Reagent Loading:
 - Add Pd(OAc)₂ (11.2 mg, 0.05 mmol) and PPh₃ (26.2 mg, 0.10 mmol).
 - Add Cs₂CO₃ (325 mg, 1.0 mmol) and the Aryl Iodide (0.6 mmol).
 - Add **1-Methyl-3-phenylindole** (103 mg, 0.5 mmol).
 - Note: If the aryl iodide is liquid, add it after the solvent.

- Solvent Addition: Add anhydrous DMA (2.5 mL) via syringe.
- Degassing: Seal the tube and purge with argon for 5 minutes (or use freeze-pump-thaw for sensitive substrates).
- Reaction: Place the vessel in a pre-heated oil bath at 125°C. Stir vigorously (800 rpm).
 - Monitoring: Check by TLC or LC-MS after 12 hours. Look for the disappearance of the indole starting material.
- Work-up:
 - Cool to room temperature.[3]
 - Dilute with EtOAc (20 mL) and filter through a pad of Celite to remove inorganic salts and Pd black.
 - Wash the filtrate with water (3 x 10 mL) and brine (1 x 10 mL) to remove DMA.
 - Dry over Na₂SO₄, filter, and concentrate under reduced pressure.
- Purification: Purify by flash column chromatography (Hexanes/EtOAc gradient).

Troubleshooting & Optimization

- Low Conversion: Switch base to Ag₂CO₃ (silver acts as a halide scavenger, promoting the reaction) or increase temperature to 140°C.
- Homocoupling of Ar-I: Reduce the initial concentration of Ar-I or add it slowly via syringe pump.
- C4 Arylation Side-Products: Rare with this system, but if observed, switch to a bulkier ligand (e.g., JohnPhos) to increase steric pressure at the metal center, favoring the more accessible C2.

Protocol 2: Rhodium(III)-Catalyzed C2-Alkenylation (Oxidative Heck)

This protocol introduces an alkene (e.g., acrylate, styrene) at the C2 position. It is distinct from the Pd-catalyzed Heck reaction because the "leaving group" on the indole is a hydrogen atom, requiring an external oxidant.

Mechanistic Insight

The active catalyst is a Cp*Rh(III) species. The reaction involves:

- C-H Activation: Reversible metalation at C2 to form a Rhodacycle.
- Olefin Insertion: Coordination and insertion of the alkene into the Rh-C bond.
- -Hydride Elimination: Releases the product.
- Re-oxidation: The reduced Rh(I) species is re-oxidized to Rh(III) by Cu(II) or Ag(I) to close the catalytic cycle.

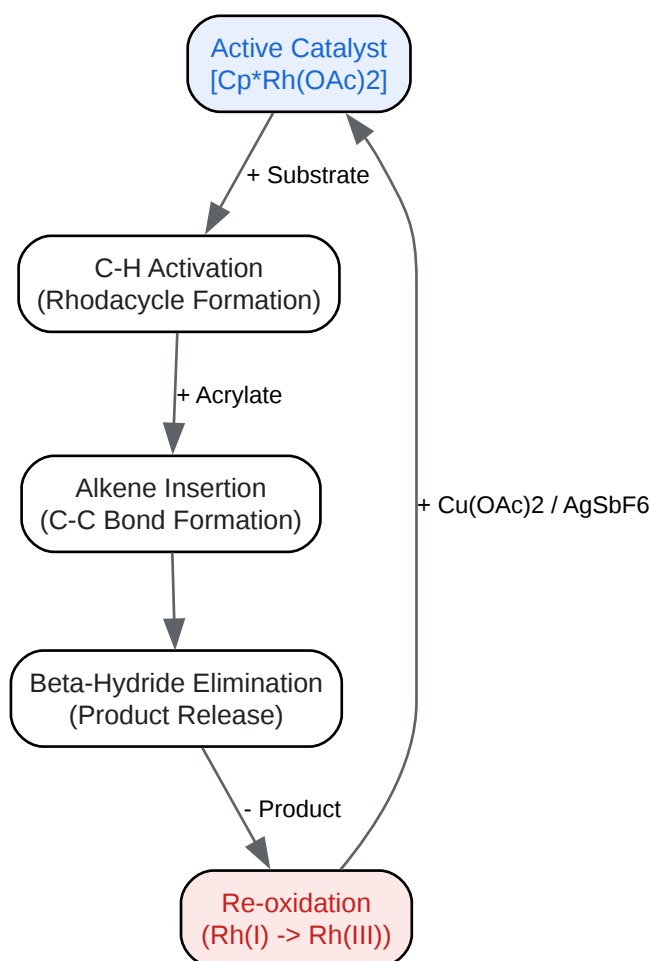

[Click to download full resolution via product page](#)

Figure 2: Catalytic cycle for the Rh(III)-catalyzed oxidative alkenylation.

Experimental Conditions

Component	Reagent	Equiv/Conc.	Role
Substrate	1-Methyl-3-phenylindole	1.0 equiv	Substrate
Alkene	Ethyl Acrylate / Styrene	2.0 equiv	Coupling Partner
Catalyst	[RhCp*Cl ₂] ₂	2.5 mol%	Active Catalyst Source
Additive	AgSbF ₆	10 mol%	Halide abstraction
Oxidant	Cu(OAc) ₂	2.0 equiv	Terminal Oxidant
Solvent	DCE or t-Amyl Alcohol	0.1 M	Solvent
Temp	100°C	16 h	Reaction Temperature

Step-by-Step Protocol

- **Catalyst Activation:** In a glovebox or under argon, weigh [RhCp*Cl₂]₂ (7.7 mg, 0.0125 mmol) and AgSbF₆ (17.2 mg, 0.05 mmol) into a reaction tube. Add 1 mL of DCE and stir for 10 mins at RT to generate the cationic Rh species (precipitate of AgCl will form).
- **Substrate Addition:** Add **1-Methyl-3-phenylindole** (103 mg, 0.5 mmol) and Cu(OAc)₂ (181 mg, 1.0 mmol).
- **Alkene Addition:** Add Ethyl Acrylate (100 mg, 1.0 mmol) and remaining DCE (4 mL).
- **Reaction:** Seal the tube and heat to 100°C for 16 hours.
 - **Visual Check:** The reaction mixture usually turns from blue/green (Cu(II)) to a reddish/brown suspension as the reaction proceeds.

- Work-up:
 - Cool to room temperature.[3]
 - Dilute with CH₂Cl₂ (20 mL).
 - Add 10% aqueous NH₄OH (10 mL) and shake vigorously (this helps complex copper salts and remove them from the organic phase).
 - Separate layers, extract aqueous layer with CH₂Cl₂ (2 x 10 mL).
 - Dry combined organics over Na₂SO₄.
- Purification: Silica gel chromatography. The product is typically a conjugated ester/styrene derivative, which is UV-active and less polar than the starting indole.

References

- Sames, D., et al. "Selective Palladium-Catalyzed C2-Arylation of N-Substituted Indoles." *Journal of the American Chemical Society*, 2004. [Link](#)
- Wang, X., et al. "Rh(III)-Catalyzed, Highly Selectively Direct C–H Alkylation of Indoles with Diazo Compounds." *Molecules*, 2016.[4] [Link](#)
- Glorius, F., et al. "Rh(III)-catalyzed direct C2-alkenylation of indoles using potassium vinyltrifluoroborate." *Chemistry - A European Journal*, 2018. [Link](#)
- Gaunt, M. J., et al. "C–H bond functionalization on the indole and pyrrole nucleus." *Chemical Reviews*, 2011. [Link](#)
- Ackermann, L. "Carboxylate-Assisted Transition-Metal-Catalyzed C–H Bond Functionalizations." *Chemical Reviews*, 2011. [Link](#)

Need Custom Synthesis?

BenchChem offers custom synthesis for rare earth carbides and specific isotopic labeling.

Email: info@benchchem.com or [Request Quote Online](#).

Sources

- 1. Directed C–H Functionalization of C3-Aldehyde, Ketone, and Acid/Ester-Substituted Free (NH) Indoles with Iodoarenes via a Palladium Catalyst System - PMC [[pmc.ncbi.nlm.nih.gov](https://pubmed.ncbi.nlm.nih.gov/)]
- 2. Rh(iii)-catalyzed regioselective C–H activation dialkenylation/annulation cascade for rapid access to 6H-isoindolo[2,1-a]indole - PMC [[pmc.ncbi.nlm.nih.gov](https://pubmed.ncbi.nlm.nih.gov/)]
- 3. Mild and General Palladium-Catalyzed Synthesis of Methyl Aryl Ethers Enabled by the Use of a Palladacycle Precatalyst - PMC [[pmc.ncbi.nlm.nih.gov](https://pubmed.ncbi.nlm.nih.gov/)]
- 4. [mdpi.com](https://www.mdpi.com) [[mdpi.com](https://www.mdpi.com)]
- To cite this document: BenchChem. [Precision C-H Functionalization of 1-Methyl-3-phenylindole: C2-Targeting Protocols]. BenchChem, [2026]. [Online PDF]. Available at: [<https://www.benchchem.com/product/b8721769/docs#precision-c-h-functionalization-of-1-methyl-3-phenylindole-c2-targeting-protocols>]

Disclaimer & Data Validity:

The information provided in this document is for Research Use Only (RUO) and is strictly not intended for diagnostic or therapeutic procedures. While BenchChem strives to provide accurate protocols, we make no warranties, express or implied, regarding the fitness of this product for every specific experimental setup.

Technical Support: The protocols provided are for reference purposes. Unsure if this reagent suits your experiment?

Need Industrial/Bulk Grade? [Request Custom Synthesis Quote](#)

BenchChem

Our mission is to be the trusted global source of essential and advanced chemicals, empowering scientists and researchers to drive progress in science and industry.

Contact

Address: 3281 E Guasti Rd
Ontario, CA 91761, United States
Phone: (601) 213-4426
Email: info@benchchem.com

Contact our Ph.D. Support Team for a compatibility check