

# Physicochemical Profiling & Therapeutic Potential of Furan-Substituted Pyrazines

**Author:** BenchChem Technical Support Team. **Date:** May 2026

## Compound of Interest

Compound Name: 2-chloro-6-(furan-2-yl)pyrazine

Cat. No.: B8708707

[Get Quote](#)

## Executive Summary

Furan-substituted pyrazines represent a unique class of heterocyclic hybrids where an electron-rich furan ring is directly coupled to an electron-deficient pyrazine core. This "push-pull" electronic architecture confers distinct physicochemical properties—ranging from specific olfactory thresholds (roasted/nutty notes) to tunable optoelectronic behaviors and specific kinase inhibitory profiles in drug discovery.

This technical guide dissects the molecular attributes of this scaffold, providing a rigorous analysis of its solubility, lipophilicity, electronic transitions, and synthetic accessibility.<sup>[1]</sup> It serves as a blueprint for researchers leveraging this moiety for high-value applications in pharmaceuticals and advanced materials.

## Chemical Architecture & Synthesis<sup>[2][3][4]</sup>

### The Donor-Acceptor (D-A) System

The core feature of furan-substituted pyrazines is the electronic interplay between the two rings:

- Pyrazine (Acceptor): A

-deficient, nitrogen-containing heterocycle with high electron affinity.[1]

- Furan (Donor): A

-excessive five-membered ring that donates electron density via resonance, despite the inductive withdrawal of the oxygen atom.[1]

This conjugation results in a reduced HOMO-LUMO gap compared to isolated rings, manifesting in red-shifted UV-absorption and enhanced polarizability—critical for binding affinity in protein pockets (e.g., kinases) and charge transfer in organic electronics.[1]

## Synthetic Pathways

Reliable access to these derivatives is governed by palladium-catalyzed cross-coupling or condensation chemistries.

Figure 1: Synthetic Workflows for Furan-Pyrazine Scaffolds

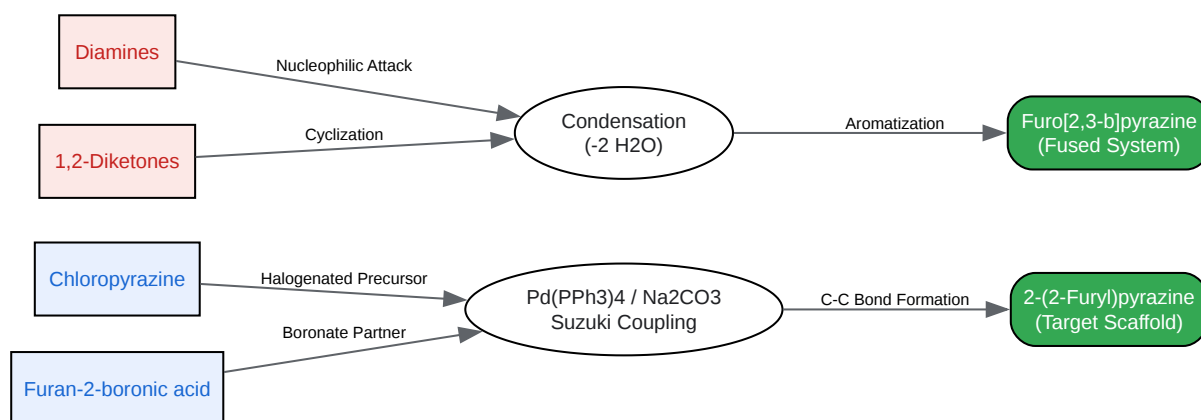

[Click to download full resolution via product page](#)

Caption: Dual synthetic strategies: Palladium-catalyzed cross-coupling for biaryl systems (top) and condensation for fused ring systems (bottom).

## Physicochemical Profiling

The following data aggregates experimental and predicted values for the parent compound, 2-(2-furyl)pyrazine, and key derivatives.

## Key Metrics Table

Property	Value / Range	Context & Implication
Molecular Weight	146.15 g/mol	Fragment-like; ideal for lead optimization (Rule of 3 compliant).
LogP (Octanol/Water)	0.5 – 1.8	Moderate lipophilicity. High membrane permeability but sufficient aqueous solubility for formulation.
Water Solubility	~9.5 g/L (Est.)	High for a neutral aromatic, driven by H-bond accepting capacity of pyrazine nitrogens.
pKa (Conj. Acid)	~0.6 – 1.5	Very weak base. The pyrazine nitrogens are less basic than pyridine due to the second nitrogen's inductive effect.
Boiling Point	240 – 255 °C	High thermal stability; relevant for gas chromatography (GC) analysis and flavor retention.
Odor Threshold	Medium Impact	Characteristic "roasted," "nutty," and "coffee" notes. <sup>[1]</sup> Used as a marker in Maillard reaction studies.
UV	270 – 310 nm	Red-shifted vs. pyrazine (260 nm) due to extended conjugation with the furan ring.

## Electronic & Solubility Nuances

- **Basicity:** The furan ring acts as a resonance donor but an inductive withdrawer. In 2-(2-furyl)pyrazine, the inductive effect often dominates the ground state, rendering the pyrazine nitrogens slightly less basic than alkyl-pyrazines.[1] This prevents protonation at physiological pH (7.4), ensuring the molecule remains neutral and membrane-permeable.[1]
- **Solubility:** Unlike purely carbocyclic analogs (e.g., phenylpyrazine), the furan oxygen and pyrazine nitrogens provide three H-bond acceptor sites, significantly enhancing solubility in polar protic solvents (Ethanol, Water).[1]

## Biological Interface & Drug Development

In medicinal chemistry, the furan-pyrazine motif serves as a bioisostere for biaryl systems (e.g., biphenyl, phenylpyridine).[1] However, specific metabolic liabilities must be managed.[1]

## Structure-Activity Relationship (SAR) & Toxicity

The furan ring is metabolically active. Cytochrome P450 enzymes can oxidize the furan ring to a reactive cis-butene-1,4-dial intermediate, which is potentially toxic (hepatotoxicity).[1] Drug design strategies often involve:

- **Blocking Metabolic Hotspots:** Substitution at the furan C5 position (e.g., methyl, chloro) to prevent ring opening.[1]
- **Scaffold Hopping:** Using the pyrazine to lower LogP while maintaining the geometric constraints of a biaryl system.

Figure 2: SAR Logic & Metabolic Fate

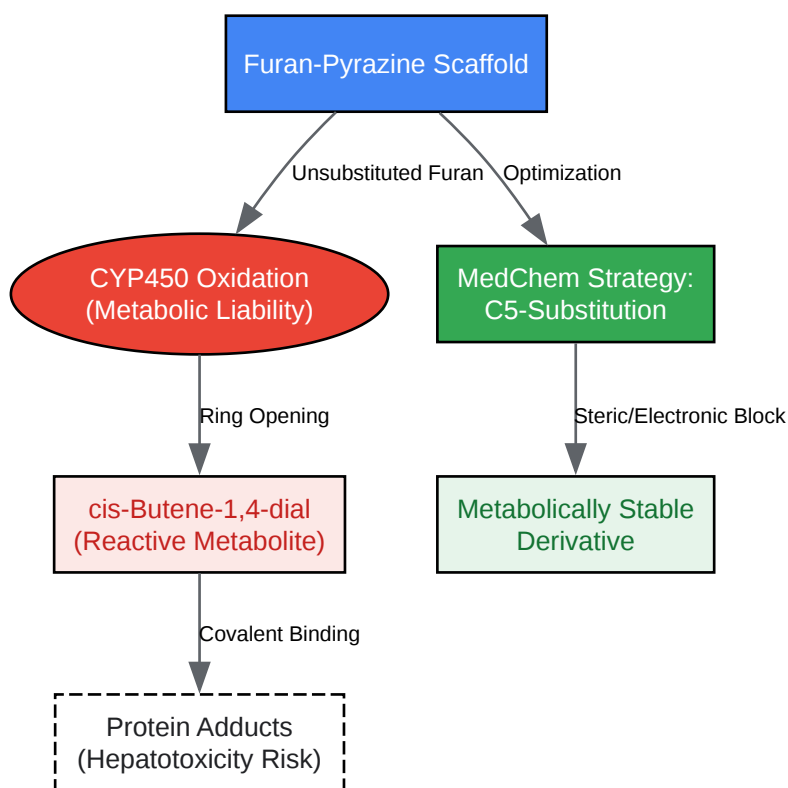

[Click to download full resolution via product page](#)

Caption: Metabolic activation pathway of the furan ring (red) and the mitigation strategy via C5-substitution (green).

## Experimental Protocols

### Protocol: Synthesis of 2-(2-Furyl)pyrazine (Suzuki Coupling)

Objective: Synthesis of the core scaffold with >95% purity.

- Reagents:
  - 2-Chloropyrazine (1.0 eq)
  - Furan-2-boronic acid (1.2 eq)
  - Pd(PPh<sub>3</sub>)<sub>4</sub> (0.05 eq)[1]

- Na<sub>2</sub>CO<sub>3</sub> (2.0 eq, 2M aqueous solution)[1]
- Solvent: 1,2-Dimethoxyethane (DME) / Water (4:1 v/v)[1]
- Procedure:
  - Degassing: Sparge the solvent mixture with Argon for 20 minutes to remove dissolved oxygen (Critical for Pd catalyst longevity).
  - Mixing: Combine halide, boronic acid, and base in the reaction vessel. Add catalyst last under positive Argon pressure.
  - Reflux: Heat to 85°C for 12–16 hours. Monitor via TLC (Hexane:EtOAc 8:2).
  - Workup: Cool to RT. Filter through Celite to remove Pd residues. Extract with Ethyl Acetate (3x). Wash organics with brine, dry over MgSO<sub>4</sub>. [1]
  - Purification: Flash column chromatography on Silica Gel. Elute with Hexane/EtOAc gradient (0-20% EtOAc).
- Validation:
  - <sup>1</sup>H NMR (CDCl<sub>3</sub>): Look for pyrazine protons (singlet/doublets ~8.5-9.0 ppm) and furan protons (multiplets ~6.5-7.5 ppm).
  - GC-MS: Confirm molecular ion (M<sup>+</sup> = 146).

## Protocol: LogP Determination (Shake-Flask Method)

Objective: Accurate measurement of lipophilicity for ADME prediction.

- Preparation: Saturate 1-octanol with water and water with 1-octanol for 24 hours prior to use.
- Equilibration: Dissolve test compound (~1 mg) in the water-saturated octanol phase. Measure UV absorbance ( ).

- Partitioning: Add an equal volume of octanol-saturated water. Shake mechanically for 60 minutes at 25°C. Centrifuge to separate phases.
- Analysis: Measure UV absorbance of the octanol phase ( ).
- Calculation:

Note: If

is too low, analyze the aqueous phase via HPLC.

## References

- Scent.vn.2-(2-Furanyl)pyrazine - Odor Profile and Properties.[2] Retrieved from [1]
- The Good Scents Company.2-(2-furyl)pyrazine and 2-(2-furyl)-5-methylpyrazine: Organoleptic and Safety Data. Retrieved from [1]
- Schneller, S. W., et al. (1984).[1] Biological activity and a modified synthesis of 8-amino-3-beta-D-ribofuranosyl-1,2,4-triazolo[4,3-a]pyrazine.[3] Journal of Medicinal Chemistry.[4] Retrieved from
- PharmaBlock.Pyrazines in Drug Discovery: Bioisosteres and Kinase Inhibitors. Retrieved from [1]
- MDPI.Effects of Pyrazine Derivatives on Photoelectric Properties. Retrieved from [1]
- Nietfeld, J. P., et al. (2011).[1] Structural Effects on the Electronic Properties of Extended Fused-Ring Thieno[3,4-b]pyrazine Analogues. The Journal of Organic Chemistry. Retrieved from [1]

### Need Custom Synthesis?

BenchChem offers custom synthesis for rare earth carbides and specific isotopic labeling.

Email: [info@benchchem.com](mailto:info@benchchem.com) or [Request Quote Online](#).

## Sources

- [1. mdpi.com \[mdpi.com\]](#)
- [2. scent.vn \[scent.vn\]](#)
- [3. Biological activity and a modified synthesis of 8-amino-3-beta-D-ribofuranosyl-1,2,4-triazolo\[4,3-a\]pyrazine, an isomer of formycin - PubMed \[pubmed.ncbi.nlm.nih.gov\]](#)
- [4. scispace.com \[scispace.com\]](#)
- To cite this document: BenchChem. [Physicochemical Profiling & Therapeutic Potential of Furan-Substituted Pyrazines]. BenchChem, [2026]. [Online PDF]. Available at: [\[https://www.benchchem.com/product/b8708707/docs#physicochemical-profiling-therapeutic-potential-of-furan-substituted-pyrazines\]](https://www.benchchem.com/product/b8708707/docs#physicochemical-profiling-therapeutic-potential-of-furan-substituted-pyrazines)

---

### Disclaimer & Data Validity:

The information provided in this document is for Research Use Only (RUO) and is strictly not intended for diagnostic or therapeutic procedures. While BenchChem strives to provide accurate protocols, we make no warranties, express or implied, regarding the fitness of this product for every specific experimental setup.

**Technical Support:** The protocols provided are for reference purposes. Unsure if this reagent suits your experiment?

**Need Industrial/Bulk Grade?** [Request Custom Synthesis Quote](#)

## BenchChem

Our mission is to be the trusted global source of essential and advanced chemicals, empowering scientists and researchers to drive progress in science and industry.

### Contact

Address: 3281 E Guasti Rd  
Ontario, CA 91761, United States  
Phone: (601) 213-4426  
Email: [info@benchchem.com](mailto:info@benchchem.com)

Contact our Ph.D. Support Team for a compatibility check