

Technical Guide: Advanced SDS Interpretation for Potent Kinase Inhibitors

Author: BenchChem Technical Support Team. **Date:** April 2026

Compound of Interest

Compound Name: 4-(chloromethyl)-2-Thiazolemethanol
Cat. No.: B8695692

[Get Quote](#)

Case Study: Vemurafenib (Surrogate for CAS 136423-14-6)[1]

Part 1: The "Black Box" of Chemical Identification

Before interpreting hazards, a scientist must validate the identity of the molecule.[1] In drug development, "research-grade" SDSs often lack the depth of "pharmaceutical-grade" documents.[1]

The Validation Protocol

When encountering an unknown or novel CAS (like the erroneous 136423-14-6), apply the Checksum Validation Algorithm before handling:

- Structure:

(Check Digit)

- Formula:

[1]

- Action: If the checksum fails, quarantine the material. It implies a labeling error or a non-standard proprietary code.

Discrepancy Analysis: Research vs. Pharma SDS

For Vemurafenib, a search reveals critical disparities:

- Vendor SDS (e.g., Cayman, Sigma): Often lists "Not Classified" or generic "Irritant (H315/H319)" due to lack of full toxicological testing.[1]
- Innovator SDS (Roche/Genentech): Lists specific target organ toxicity (STOT), reproductive risks, and environmental hazards based on clinical data.[1]
- Scientist's Mandate: Always assume the Innovator profile for safety banding.

Part 2: Hazard Profiling & Mechanistic Toxicity

An SDS is not just a list of H-codes; it is a map of biological interaction. For a kinase inhibitor like Vemurafenib, safety is dictated by its Mechanism of Action (MoA).[1]

GHS Classification & Translation

GHS Code	Hazard Statement	Mechanistic Interpretation for Researchers
H302	Harmful if swallowed	Bioavailability: High oral bioavailability implies systemic exposure risk from dust ingestion.[1]
H360/H361	Suspected of damaging fertility/unborn child	Target: BRAF inhibition affects developmental pathways.[1] Strict pregnancy exclusion required.[1]
H372	Causes damage to organs (Skin, Liver)	Off-Target: Paradoxical MAPK activation leads to cutaneous squamous cell carcinomas (cuSCC).[1]
H410	Very toxic to aquatic life (Long lasting)	Persistence: Halogenated structure (Cl, F) resists biodegradation.[1]

The "Hidden" Hazard: Photosensitivity

Clinical data reveals Vemurafenib causes severe photosensitivity (UVA range).[1] Most standard SDSs miss this unless updated with clinical findings.[1]

- Protocol Adjustment: Handling requires UV-filtered lighting or amber glassware.[1] Workers must avoid direct sunlight after exposure.

Part 3: Occupational Hygiene Strategy (The "Band")

We do not rely on "generic" OELs. We assign an Occupational Exposure Band (OEB) based on potency.[2]

Potency Calculation

- Therapeutic Dose: ~960 mg/day (High burden, lower potency than some cytotoxic payloads). [1]

- OEL Derivation:

[1]

- POD (Point of Departure): NOAEL from animal studies.[1]
- Result: Vemurafenib is typically OEB 3 or OEB 4 (1–10 $\mu\text{g}/\text{m}^3$), requiring containment.[1]

Containment Logic (Hierarchy of Controls)

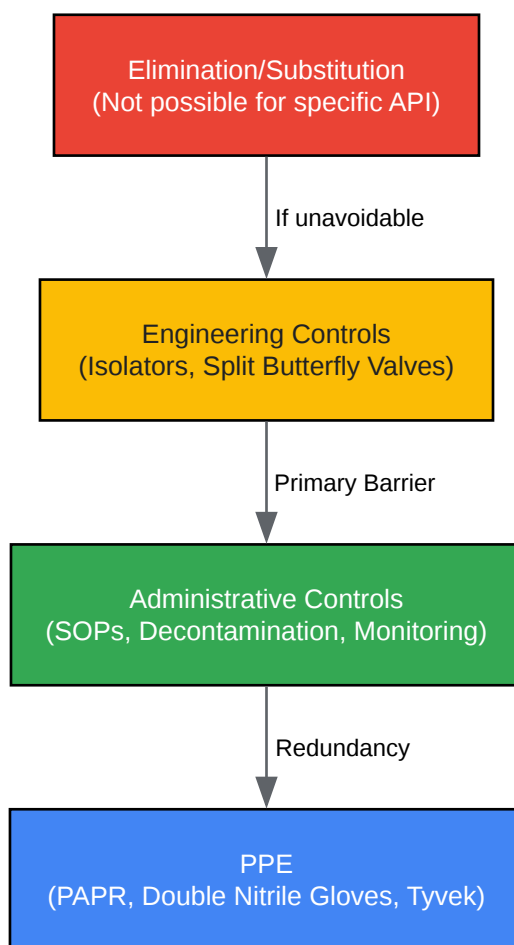

[Click to download full resolution via product page](#)

Figure 1: Hierarchy of Controls for Handling Potent Kinase Inhibitors.

Part 4: Experimental Protocols & Emergency Response

Standard Operating Procedure (SOP): Weighing & Solubilization

Objective: Safely prepare a 10 mM stock solution in DMSO.

- Preparation:
 - Don PPE: Double nitrile gloves (0.11 mm min), Tyvek lab coat, N95 or PAPR (if powder >1g).[1]
 - Activate Powder Containment Hood (verify flow: 100 fpm).
- Weighing:
 - Use an analytical balance inside the hood.
 - Technique: Use a static-free spatula. Vemurafenib is a lipophilic solid; static charge can disperse dust.
- Solubilization:
 - Add DMSO gently down the side of the vial to minimize aerosolization.[1]
 - Vortex with cap sealed and Parafilmed.[1]
- Decontamination:
 - Wipe balance and hood deck with 10% Sodium Dodecyl Sulfate (SDS) or surfactant-based cleaner. Why? Organic solvents (ethanol) may spread lipophilic drugs; surfactants encapsulate them.

Emergency Spill Response (The "Pinch" Point)

- Scenario: 500 mg powder spill outside the hood.
- Immediate Action: Evacuate area (15 min) to let aerosols settle.[1]
- Cleanup:

- Don Full-Face Respirator (P100).
- Cover spill with wet paper towels (water/surfactant mix) to prevent dust.
- Scoop; do not sweep.[1]
- Place in hazardous waste (Incineration only).

Part 5: Environmental Stewardship

Vemurafenib is H410 (Very toxic to aquatic life).[1][3]

- Disposal: Never pour down the drain. All rinsate must be collected.
- Fate: The halogenated aromatic rings (Chlorine/Fluorine) make the molecule resistant to hydrolysis.[1] It will persist in sediment.

Decision Logic for Novel Compounds

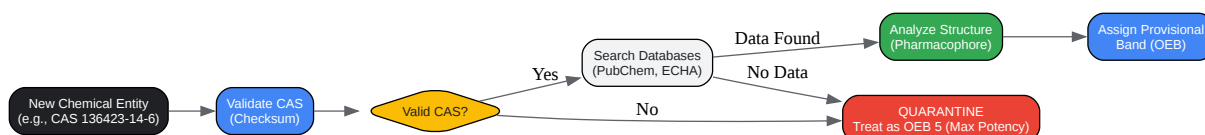

[Click to download full resolution via product page](#)

Figure 2: Decision Tree for Risk Assessment of Novel/Unverified Compounds.

References

- European Chemicals Agency (ECHA). Guidance on the Application of the CLP Criteria. ECHA, 2024.[1] [\[Link\]](#)
- PubChem.Vemurafenib (CID 42611257) Compound Summary. National Library of Medicine. [\[Link\]](#)

- Occupational Safety and Health Administration (OSHA). Hazard Classification Guidance for Manufacturers, Importers, and Employers. [[Link](#)]
- SafeWork Australia. Guidance on the Interpretation of Workplace Exposure Standards for Airborne Contaminants. [[Link](#)]
- Roche. Zelboraf (Vemurafenib) Prescribing Information & Safety Data. [[Link](#)]

Need Custom Synthesis?

BenchChem offers custom synthesis for rare earth carbides and specific isotopic labeling.

Email: info@benchchem.com or [Request Quote Online](#).

Sources

- 1. Shepherd University | Safety | Sigma Aldrich Sds [shepherd.edu]
- 2. Considerations for setting occupational exposure limits for novel pharmaceutical modalities - PMC [[pmc.ncbi.nlm.nih.gov](https://pubmed.ncbi.nlm.nih.gov)]
- 3. media.cellsignal.com [media.cellsignal.com]
- To cite this document: BenchChem. [Technical Guide: Advanced SDS Interpretation for Potent Kinase Inhibitors]. BenchChem, [2026]. [Online PDF]. Available at: [<https://www.benchchem.com/product/b8695692/docs#technical-guide-advanced-sds-interpretation-for-potent-kinase-inhibitors>]

Disclaimer & Data Validity:

The information provided in this document is for Research Use Only (RUO) and is strictly not intended for diagnostic or therapeutic procedures. While BenchChem strives to provide accurate protocols, we make no warranties, express or implied, regarding the fitness of this product for every specific experimental setup.

Technical Support: The protocols provided are for reference purposes. Unsure if this reagent suits your experiment?

Need Industrial/Bulk Grade? [Request Custom Synthesis Quote](#)

BenchChem

Our mission is to be the trusted global source of essential and advanced chemicals, empowering scientists and researchers to drive progress in science and industry.

Contact

Address: 3281 E Guasti Rd

Ontario, CA 91761, United States

Phone: (601) 213-4426

Email: info@benchchem.com

[Contact our Ph.D. Support Team for a compatibility check](#)