

# Step-by-step synthesis of adamantane-functionalized ethers

**Author:** BenchChem Technical Support Team. **Date:** April 2026

## Compound of Interest

**Compound Name:** 1-  
[[Chloromethoxy)methyl]adamanta  
ne

**Cat. No.:** B8679709

[Get Quote](#)

An In-Depth Technical Guide to the Synthesis of Adamantane-Functionalized Ethers

For Researchers, Scientists, and Drug Development Professionals

## Introduction: The Adamantane Scaffold in Modern Chemistry

First isolated in 1933, adamantane is a unique, perfectly symmetrical, and rigid tricyclic hydrocarbon.[1] Its diamondoid structure confers exceptional properties, including high thermal stability, metabolic resistance, and a well-defined three-dimensional geometry.[1][2] These characteristics have established adamantane as a "privileged scaffold" in medicinal chemistry and materials science.[2][3] Incorporating the adamantane moiety can significantly enhance a molecule's lipophilicity, which can improve its ability to cross biological membranes like the blood-brain barrier, and modulate its absorption, distribution, metabolism, and excretion (ADME) properties.[3][4]

Adamantane-functionalized ethers are a crucial class of derivatives. The ether linkage provides a stable, chemically robust connection to other functional groups, making these compounds valuable as pharmaceutical intermediates, polymer building blocks, and molecular probes.<sup>[5]</sup> This guide provides a detailed exploration of the primary synthetic routes to adamantane-functionalized ethers, offering step-by-step protocols and explaining the rationale behind key experimental choices.

## Core Synthetic Strategies: A Comparative Overview

The synthesis of adamantane ethers can be approached through several reliable methods. The choice of strategy often depends on the starting materials' availability, the steric hindrance around the reaction centers, and the desired stereochemical outcome.

- **Williamson Ether Synthesis:** This classical SN<sub>2</sub> reaction remains the most direct and widely used method for preparing ethers.<sup>[6]</sup> It involves the deprotonation of an adamantyl alcohol to form a potent nucleophile (an alkoxide), which then displaces a halide from an alkyl halide. While robust, its effectiveness can be limited by the steric bulk of the adamantane cage, particularly with secondary alcohols like 2-adamantanol, where competing elimination reactions can occur.<sup>[6][7]</sup>
- **Mitsunobu Reaction:** This powerful reaction facilitates the conversion of a primary or secondary alcohol into an ether using triphenylphosphine (PPh<sub>3</sub>) and an azodicarboxylate, such as diethyl azodicarboxylate (DEAD).<sup>[8][9]</sup> A key advantage of the Mitsunobu reaction is that it proceeds with a clean inversion of stereochemistry at the alcohol carbon, making it invaluable for stereospecific syntheses.<sup>[10][11]</sup> It is particularly effective for coupling alcohols with phenolic compounds or other acidic pronucleophiles.<sup>[9][10]</sup>
- **Phase-Transfer Catalysis (PTC):** This technique is not a standalone synthesis method but rather a powerful enhancement for reactions occurring in biphasic systems, such as the Williamson ether synthesis.<sup>[12][13]</sup> A phase-transfer catalyst, typically a quaternary ammonium salt, transports the alkoxide nucleophile from the aqueous (or solid) phase into the organic phase where the alkyl halide resides, dramatically accelerating the reaction rate and often improving yields under milder conditions.<sup>[14][15][16]</sup>

## Experimental Protocols and Methodologies

The following protocols provide detailed, step-by-step procedures for the synthesis of adamantane-functionalized ethers.

## Protocol 1: Williamson Ether Synthesis of 2-Methoxyadamantane

This protocol details the synthesis of a representative 2-alkoxyadamantane from the sterically hindered secondary alcohol, 2-adamantanol. The use of a strong base like sodium hydride (NaH) is critical for deprotonating the alcohol to form the nucleophilic alkoxide.[6]

Causality Behind Experimental Choices:

- Inert Atmosphere (Argon/Nitrogen): Sodium hydride is highly reactive and pyrophoric, reacting violently with water and moisture in the air. An inert atmosphere is essential to prevent quenching of the reagent and ensure safety.[6]
- Anhydrous THF: Tetrahydrofuran (THF) is an excellent solvent for this reaction, but it must be anhydrous. Any water present will react with NaH, consuming the base and reducing the yield.[6][17]
- Initial Cooling (0 °C): The deprotonation of the alcohol with NaH is an exothermic reaction that generates hydrogen gas.[6] Cooling the reaction to 0 °C controls the reaction rate and the rate of gas evolution, preventing dangerous pressure buildup and side reactions.
- Heating (60 °C): The SN2 displacement of iodide by the bulky sodium 2-adamantoxide is slow at room temperature. Heating the reaction provides the necessary activation energy to drive the alkylation to completion in a reasonable timeframe.[6]

Reaction Scheme:

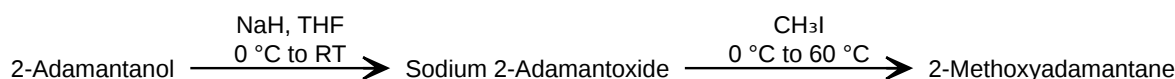

[Click to download full resolution via product page](#)

Caption: Synthesis of 2-Methoxyadamantane via Williamson Ether Synthesis.

## Materials:

- 2-Adamantanol
- Sodium hydride (NaH), 60% dispersion in mineral oil
- Anhydrous Tetrahydrofuran (THF)
- Methyl iodide (CH<sub>3</sub>I)
- Deionized Water
- Diethyl ether
- Saturated aqueous sodium chloride solution (Brine)
- Anhydrous magnesium sulfate (MgSO<sub>4</sub>)
- Argon or Nitrogen gas

## Equipment:

- Three-necked round-bottom flask
- Magnetic stirrer and stir bar
- Reflux condenser
- Dropping funnel
- Ice bath and heating mantle
- Separatory funnel
- Rotary evaporator

## Procedure:

- Reaction Setup: A dry three-necked round-bottom flask equipped with a magnetic stirrer, reflux condenser, and dropping funnel is thoroughly flushed with an inert gas (e.g., argon).[6]
- Alkoxide Formation:
  - Charge the flask with sodium hydride (1.2 equivalents, 60% dispersion).[6]
  - Add anhydrous THF to create a suspension.
  - In a separate flask, dissolve 2-adamantanol (1.0 equivalent) in anhydrous THF.
  - Slowly add the 2-adamantanol solution to the NaH suspension at 0 °C (using an ice bath). [6]
  - Once the addition is complete, allow the mixture to warm to room temperature and stir for 1 hour, or until hydrogen gas evolution ceases. This signals the formation of sodium 2-adamantoxide.[6]
- Alkylation:
  - Cool the reaction mixture back to 0 °C.
  - Add methyl iodide (1.5 equivalents) dropwise.[6]
  - After the addition, allow the reaction to warm to room temperature and then heat to 60 °C for 4-6 hours. Monitor the reaction's progress using Thin-Layer Chromatography (TLC).[6]
- Work-up and Purification:
  - Cool the reaction to room temperature and carefully quench by the slow, dropwise addition of water.
  - Transfer the mixture to a separatory funnel and extract three times with diethyl ether.[6]
  - Wash the combined organic layers with brine, dry over anhydrous MgSO<sub>4</sub>, filter, and concentrate the solvent using a rotary evaporator.[6]

- Purify the crude product by column chromatography on silica gel (e.g., using a hexane/ethyl acetate gradient) to yield pure 2-methoxyadamantane.[6]

Quantitative Data Summary:

| Parameter                                   | Value   |
|---|---|
| Starting Material                           | 2-Adamantanol   |
| Primary Reagents                            | Sodium hydride (NaH), Methyl iodide (CH <sub>3</sub> I) |
| Molar Ratio (Alcohol:NaH:CH <sub>3</sub> I) | 1.0 : 1.2 : 1.5[6]                                      |
| Solvent                                     | Anhydrous Tetrahydrofuran (THF)                         |
| Deprotonation Temperature                   | 0 °C to Room Temperature[6]                             |
| Alkylation Temperature                      | 0 °C to 60 °C[6]  |
| Reaction Time                               | 4-6 hours[6]  |

## Protocol 2: Mitsunobu Reaction for Adamantane-Phenol Ether Synthesis

This protocol describes the formation of an ether by coupling an adamantyl alcohol with a phenol, a process where the Williamson synthesis often fails. The Mitsunobu reaction is ideal for this transformation.[10]

Causality Behind Experimental Choices:

- Reagent Order: Typically, the alcohol, phenol, and PPh<sub>3</sub> are mixed first before the slow addition of DEAD.[8] This allows the formation of the initial phosphonium salt before the key betaine intermediate is formed upon DEAD addition. Pre-forming the betaine (adding DEAD to PPh<sub>3</sub> first) can sometimes yield better results if the standard procedure is unsuccessful.[8]
- Cooling (0 °C): The reaction is highly exothermic. Initial cooling is crucial to control the reaction rate and prevent the formation of byproducts.[8]

- Acidic Pronucleophile: The Mitsunobu reaction works best with pronucleophiles having a pKa of 11 or lower, such as phenols and carboxylic acids.[10] This is because the betaine intermediate formed from PPh<sub>3</sub> and DEAD is basic enough to deprotonate these nucleophiles, but not basic enough for less acidic compounds like simple alcohols.[10]

Reaction Mechanism:

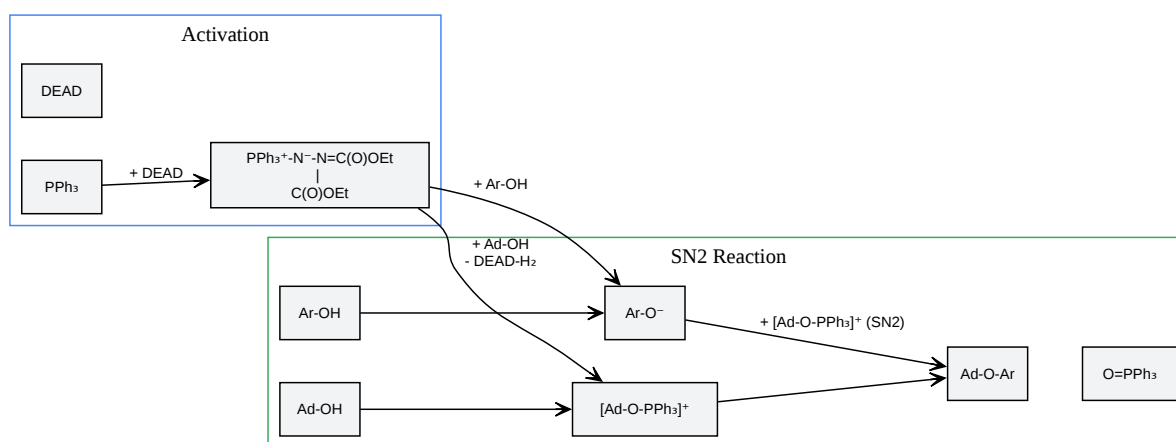

[Click to download full resolution via product page](#)

Caption: Simplified mechanism of the Mitsunobu reaction for ether synthesis.

Materials:

- 1-Adamantanol
- Phenol (or substituted phenol)
- Triphenylphosphine (PPh<sub>3</sub>)

- Diethyl azodicarboxylate (DEAD) or Diisopropyl azodicarboxylate (DIAD)
- Anhydrous Tetrahydrofuran (THF)
- Ethyl acetate or Dichloromethane
- Silica gel for chromatography

#### Procedure:

- **Reaction Setup:** In a dry round-bottom flask under an inert atmosphere, dissolve 1-adamantanol (1.0 equivalent), the phenol (1.1 equivalents), and triphenylphosphine (1.2 equivalents) in anhydrous THF.
- **Reagent Addition:** Cool the solution to 0 °C in an ice bath.
- **Slowly add DEAD or DIAD (1.2 equivalents) dropwise to the stirred solution. An exothermic reaction and color change (typically to a yellow or orange hue) will be observed.**
- **Reaction:** After the addition is complete, remove the ice bath and allow the reaction to stir at room temperature for 6-12 hours, or until TLC analysis indicates the consumption of the starting alcohol.
- **Work-up and Purification:**
  - Concentrate the reaction mixture under reduced pressure.
  - The crude residue will contain the desired ether along with triphenylphosphine oxide (TPPO) and the hydrazine byproduct.
  - Purify the product directly by column chromatography on silica gel. The less polar ether will elute before the highly polar byproducts.

## Characterization of Adamantane-Functionalized Ethers

Structural confirmation of the synthesized ethers is paramount. Nuclear Magnetic Resonance (NMR) spectroscopy is the most powerful tool for this purpose.[18]

## General Protocol for NMR Characterization

- Sample Preparation:
  - Weigh approximately 5-10 mg of the purified adamantane ether.[18]
  - Dissolve the sample in ~0.6 mL of a suitable deuterated solvent (e.g., CDCl<sub>3</sub>) in a clean NMR tube.[18]
  - Add a small amount of tetramethylsilane (TMS) as an internal reference standard ( $\delta = 0.00$  ppm).[18]
- <sup>1</sup>H NMR Acquisition:
  - Record the spectrum on a 300 MHz or higher spectrometer.
  - The characteristic broad singlets or multiplets of the adamantyl protons typically appear in the  $\delta$  1.5-2.2 ppm region.
  - Protons on the carbon bearing the ether oxygen will be shifted downfield. For example, in 2-methoxyadamantane, the methoxy protons (–OCH<sub>3</sub>) will appear as a sharp singlet around  $\delta$  3.3 ppm.
- <sup>13</sup>C NMR Acquisition:
  - Perform a proton-decoupled experiment.
  - The adamantane cage carbons typically resonate between  $\delta$  28-70 ppm.[19] The carbon atom attached to the ether oxygen will be significantly shifted downfield (e.g.,  $> \delta$  70 ppm).
- Complementary Techniques:
  - Mass Spectrometry (MS): Confirms the molecular weight of the synthesized ether.[18]

- Infrared (IR) Spectroscopy: Shows a characteristic C-O ether stretch, typically in the 1050-1150  $\text{cm}^{-1}$  region.[18]

Expected NMR Data for 1-Methoxyadamantane:

| Nucleus             | Chemical Shift ( $\delta$ , ppm) | Multiplicity | Assignment                       |
|---------------------|----------------------------------|--------------|----------------------------------|
| $^1\text{H}$ NMR    | ~3.3                             | s            | -OCH <sub>3</sub>                |
|                     | ~2.1                             | br s         | 3 x CH (bridgehead)              |
|                     | ~1.7                             | m            | 12 x CH <sub>2</sub> (methylene) |
| $^{13}\text{C}$ NMR | ~75                              |              | C-O (bridgehead)                 |
|                     | ~50                              |              | -OCH <sub>3</sub>                |
|                     | ~40                              |              | 6 x CH <sub>2</sub>              |
|                     | ~30                              |              | 3 x CH                           |

## Overall Experimental Workflow

The synthesis and characterization of an adamantane-functionalized ether follow a logical progression from reaction setup to final analysis.

Caption: General workflow for the synthesis and characterization of adamantane ethers.

## Conclusion

The synthesis of adamantane-functionalized ethers is a critical capability for researchers in drug discovery and materials science. The Williamson ether synthesis and the Mitsunobu reaction represent two of the most powerful and versatile methods to achieve this goal. By understanding the mechanisms and the rationale behind the specific experimental conditions outlined in these protocols, scientists can reliably and efficiently synthesize these valuable compounds for a wide array of applications. Proper characterization, primarily through NMR spectroscopy, is essential to confirm the structure and purity of the final products.

## References

- Benchchem. (n.d.). Application Notes and Protocols for the Williamson Ether Synthesis of 2-Adamantyl Ethers.
- Benchchem. (n.d.). A Comparative Guide to the  $^1\text{H}$  and  $^{13}\text{C}$  NMR Characterization of Brominated Adamantane Derivatives.
- Štefane, B., & Požgan, F. (2023). Synthesis of 1,2-Disubstituted Adamantane Derivatives by Construction of the Adamantane Framework. *Molecules*, 28(22), 7695. Retrieved from [[Link](#)]
- F.J. et al. (n.d.). Elucidating the Structures of Substituted Adamantyl Esters and Ethers Using Rotational Spectroscopy and Computations. UVaDOC Principal.
- Neale, C. A., & Martin, A. D. (2020). Direct radical functionalization methods to access substituted adamantanes and diamondoids. *Organic & Biomolecular Chemistry*, 18(39), 7731–7747. Retrieved from [[Link](#)]
- Jágr, M., et al. (2023). Elucidating the Structures of Substituted Adamantyl Esters and Ethers Using Rotational Spectroscopy and Computations. *Chemistry – A European Journal*, 29(15), e202203306. Retrieved from [[Link](#)]
- (2025). Adamantane Derivatives in the 21st Century: Emerging Therapeutic Frontiers and Future Research. *Journal of Chemical Health Risks*.
- Savage, G. P., et al. (2024). Unlocking therapeutic potential: the role of adamantane in drug discovery. *Australian Journal of Chemistry*, 77(8), CH24075.
- (n.d.). Synthesis of Functionalized Adamantane Derivatives: (3 + 1)-Scaffolds for Applications in Medicinal and Material Chemistry. ResearchGate. Retrieved from [[Link](#)]
- Linti, G., & Wessing, J. (2024). Adamantane-type clusters: compounds with a ubiquitous architecture but a wide variety of compositions and unexpected materials properties. *Chemical Science*, 15(21), 7805-7821. Retrieved from [[Link](#)]
- Wikipedia. (n.d.). Mitsunobu reaction. Retrieved from [[Link](#)]
- (n.d.). Synthesis of adamantylidene adamantane from adamantanone.
- (n.d.). Adamantane Synthesis. *Organic Syntheses*. Retrieved from [[Link](#)]

- Spilovska, K., et al. (2016). Adamantane - A Lead Structure for Drugs in Clinical Practice. *Current Medicinal Chemistry*, 23(29), 3245-3266. Retrieved from [[Link](#)]
- Gjoshi, E., et al. (2023). Adamantane-containing drug delivery systems. *Pharmacia*, 70(4), 1017-1027. Retrieved from [[Link](#)]
- Stepanov, A. G., et al. (2019). Synthesis of Sterically Congested 2,2'-Bi(Adamantyl)-Based Alcohol and Amines. *The Journal of Organic Chemistry*, 84(23), 15467-15474. Retrieved from [[Link](#)]
- Organic Synthesis. (n.d.). Mitsunobu reaction. Retrieved from [[Link](#)]
- ResearchGate. (2018). Synthesis of novel polyarylates based adamantane via phase transfer catalysis. Retrieved from [[Link](#)]
- Organic Chemistry Tutor. (n.d.). Mitsunobu Reaction. Retrieved from [[Link](#)]
- Benchchem. (n.d.). Application Notes and Protocols for the Incorporation of Adamantane into Heterocyclic Compounds.
- Batool, S., et al. (2022). Mitsunobu Reaction: A Powerful Tool for the Synthesis of Natural Products: A Review. *Molecules*, 27(19), 6542. Retrieved from [[Link](#)]
- Benchchem. (n.d.). Synthetic Routes for Functionalized Adamantane Derivatives: Application Notes and Protocols.
- (n.d.). Phase transfer catalysis.
- Wikipedia. (n.d.). Williamson ether synthesis. Retrieved from [[Link](#)]
- Master Organic Chemistry. (2014). The Williamson Ether Synthesis. Retrieved from [[Link](#)]
- Benchchem. (n.d.). Application Notes and Protocols for the Characterization of Adamantane-Containing Polymers.
- Głowacka, A., et al. (2024). Novel Adamantane Derivatives: Synthesis, Cytotoxicity and Antimicrobial Properties. *Molecules*, 29(9), 2024. Retrieved from [[Link](#)]
- Stepanov, A. G., et al. (2019). Synthesis of Sterically Congested 2,2'-Bi(Adamantyl)-Based Alcohol and Amines. *The Journal of Organic Chemistry*, 84(23), 15467-15474. Retrieved

from [\[Link\]](#)

- Organic Chemistry Portal. (n.d.). Mitsunobu Reaction. Retrieved from [\[Link\]](#)
- Khan Academy. (n.d.). Williamson ether synthesis. Retrieved from [\[Link\]](#)
- (2022). A Minireview of Phase-Transfer Catalysis and Recent Trends. Biomedical Research and Therapy, 9(8), 5195-5205. Retrieved from [\[Link\]](#)
- (n.d.). Preparation of 1-Adamantyl Ketones: Structure, Mechanism of Formation and Biological Activity of Potential By-Products.
- Koshchii, I., et al. (2025). SYNTHESIS OF ADAMANTYL-CONTAINING AMID ALKYLING AGE. Norwegian Journal of development of the International Science, 166, 19-22.
- (n.d.). Novel Synthesis of Heterocycle-Containing Adamantane Derivatives.

### Need Custom Synthesis?

BenchChem offers custom synthesis for rare earth carbides and specific isotopic labeling.

Email: [info@benchchem.com](mailto:info@benchchem.com) or [Request Quote Online](#).

## Sources

1. [jchr.org](http://jchr.org) [[jchr.org](http://jchr.org)]
2. [pdf.benchchem.com](http://pdf.benchchem.com) [[pdf.benchchem.com](http://pdf.benchchem.com)]
3. [pdf.benchchem.com](http://pdf.benchchem.com) [[pdf.benchchem.com](http://pdf.benchchem.com)]
4. [connectsci.au](http://connectsci.au) [[connectsci.au](http://connectsci.au)]
5. [discovery.researcher.life](http://discovery.researcher.life) [[discovery.researcher.life](http://discovery.researcher.life)]
6. [pdf.benchchem.com](http://pdf.benchchem.com) [[pdf.benchchem.com](http://pdf.benchchem.com)]
7. Williamson ether synthesis - Wikipedia [[en.wikipedia.org](http://en.wikipedia.org)]
8. Mitsunobu reaction - Wikipedia [[en.wikipedia.org](http://en.wikipedia.org)]
9. Mitsunobu Reaction: A Powerful Tool for the Synthesis of Natural Products: A Review - PMC [[pmc.ncbi.nlm.nih.gov](http://pmc.ncbi.nlm.nih.gov)]
10. [organicchemistrytutor.com](http://organicchemistrytutor.com) [[organicchemistrytutor.com](http://organicchemistrytutor.com)]
11. Mitsunobu Reaction [[organic-chemistry.org](http://organic-chemistry.org)]

- [12. researchgate.net \[researchgate.net\]](https://www.researchgate.net)
- [13. Phase Transfer Catalysts | Tokyo Chemical Industry Co., Ltd.\(APAC\) \[tcichemicals.com\]](https://www.tcichemicals.com)
- [14. littleflowercollege.edu.in \[littleflowercollege.edu.in\]](https://www.littleflowercollege.edu.in)
- [15. merckmillipore.com \[merckmillipore.com\]](https://www.merckmillipore.com)
- [16. biomedres.us \[biomedres.us\]](https://www.biomedres.us)
- [17. masterorganicchemistry.com \[masterorganicchemistry.com\]](https://www.masterorganicchemistry.com)
- [18. pdf.benchchem.com \[pdf.benchchem.com\]](https://pdf.benchchem.com)
- [19. mdpi.com \[mdpi.com\]](https://www.mdpi.com)
- To cite this document: BenchChem. [Step-by-step synthesis of adamantane-functionalized ethers]. BenchChem, [2026]. [Online PDF]. Available at: [\[https://www.benchchem.com/product/b8679709/docs#step-by-step-synthesis-of-adamantane-functionalized-ethers\]](https://www.benchchem.com/product/b8679709/docs#step-by-step-synthesis-of-adamantane-functionalized-ethers)

---

#### Disclaimer & Data Validity:

The information provided in this document is for Research Use Only (RUO) and is strictly not intended for diagnostic or therapeutic procedures. While BenchChem strives to provide accurate protocols, we make no warranties, express or implied, regarding the fitness of this product for every specific experimental setup.

**Technical Support:** The protocols provided are for reference purposes. Unsure if this reagent suits your experiment?

**Need Industrial/Bulk Grade?** [Request Custom Synthesis Quote](#)

## BenchChem

Our mission is to be the trusted global source of essential and advanced chemicals, empowering scientists and researchers to drive progress in science and industry.

#### Contact

Address: 3281 E Guasti Rd  
Ontario, CA 91761, United States  
Phone: (601) 213-4426  
Email: [info@benchchem.com](mailto:info@benchchem.com)

Contact our Ph.D. Support Team for a compatibility check