

Comparative Guide: Mass Spectrometry Fragmentation of Methyl-Substituted Dioxanes

Author: BenchChem Technical Support Team. **Date:** April 2026

Compound of Interest

Compound Name: *5-Methyl-1,3-dioxane-2-carboxylic acid*

CAS No.: *712353-85-0*

Cat. No.: *B8663068*

[Get Quote](#)

Executive Summary

Methyl-substituted dioxanes are ubiquitous structural motifs in medicinal chemistry, serving as pharmacophores, chiral auxiliaries, and protected diol/carbonyl equivalents. Their structural characterization is critical but challenging due to the subtle energetic differences between isomers.

This guide compares the Electron Ionization (EI) fragmentation behaviors of 1,3-dioxane and 1,4-dioxane derivatives. Unlike Nuclear Magnetic Resonance (NMR), which relies on magnetic environments, EI-MS differentiates these isomers based on the thermodynamic stability of their radical cations and the kinetic favorability of specific cleavage pathways (e.g.,

-cleavage, Retro-Diels-Alder).

Key Takeaway: The "performance" of MS in this context is defined by its ability to resolve stereochemistry through ion abundance ratios, a capability driven by the memory of the neutral molecule's conformation (axial vs. equatorial substituents) in the excited ion state.

Mechanistic Foundations of Dioxane Fragmentation

To interpret the spectra of methyl-dioxanes, one must understand the causality behind the bond breaks. The fragmentation is not random; it follows specific high-energy pathways.

The 1,3-Dioxane Pathway

The 1,3-dioxane ring is prone to ring opening via

-cleavage adjacent to the oxygen atoms. This is often followed by a Retro-Diels-Alder (RDA) type fragmentation or a McLafferty-like rearrangement if the side chain allows.

- Primary Driver: Formation of a resonance-stabilized oxonium ion.
- Stereochemical Effect: In 1,3-dioxanes, substituents at the C2, C4, and C6 positions can adopt axial or equatorial orientations. The loss of a substituent (e.g., a methyl group) is kinetically favored when the bond to be broken is anti-periplanar to a lone pair on the ring oxygen, or when the loss relieves 1,3-diaxial strain.

The 1,4-Dioxane Pathway

The 1,4-dioxane system is more symmetric but less stable upon ionization due to the lack of a central acetal carbon (C2 in 1,3-dioxane) that can stabilize positive charge through double oxygen resonance.

- Primary Driver: C-C bond cleavage followed by expulsion of neutral molecules (e.g., formaldehyde, ethene).

Comparative Analysis: Regio- and Stereoisomers

Regioisomer Differentiation: 1,3- vs. 1,4-Dioxanes

The position of the oxygen atoms dictates the fragmentation "fingerprint."

Feature	2-Methyl-1,3-Dioxane	2-Methyl-1,4-Dioxane
Molecular Ion ()	Weak or Absent (Unstable acetal center)	Distinct (More stable ether linkages)
Base Peak Origin	Loss of H or from C2 (forms stable oxonium)	Ring cleavage (complex mixed pathways)
Diagnostic Ion	m/z 101 () or m/z 87 ()	m/z 87 () and m/z 58 (RDA fragment)
Mechanism	Direct -cleavage at the acetal carbon.	Ring opening loss of or

Stereochemical Differentiation: Cis vs. Trans

This is the most critical application for advanced characterization. The cis and trans isomers of substituted 1,3-dioxanes (e.g., 2,4,6-trimethyl-1,3-dioxane) exhibit distinct ion abundance ratios.[1]

- The "Memory Effect": Although ionization is fast (Franck-Condon principle), the decomposing ions often retain the conformational energy landscape of the neutral parent.
- Performance Metric: The ratio of the peak to the molecular ion or other fragments.
 - Trans-Isomers: Often have one methyl group forced into an axial position (high energy).[2] Loss of this axial methyl group relieves 1,3-diaxial strain, leading to a higher abundance of the

ion compared to the cis isomer.

- Cis-Isomers: Typically adopt a conformation where all large substituents are equatorial (most stable). Loss of an equatorial methyl is electronically less favored and does not provide the same strain relief, resulting in a lower abundance

peak.

Visualized Fragmentation Pathways

The following diagrams illustrate the logical flow of fragmentation for the two distinct dioxane classes.

1,3-Dioxane Fragmentation Logic

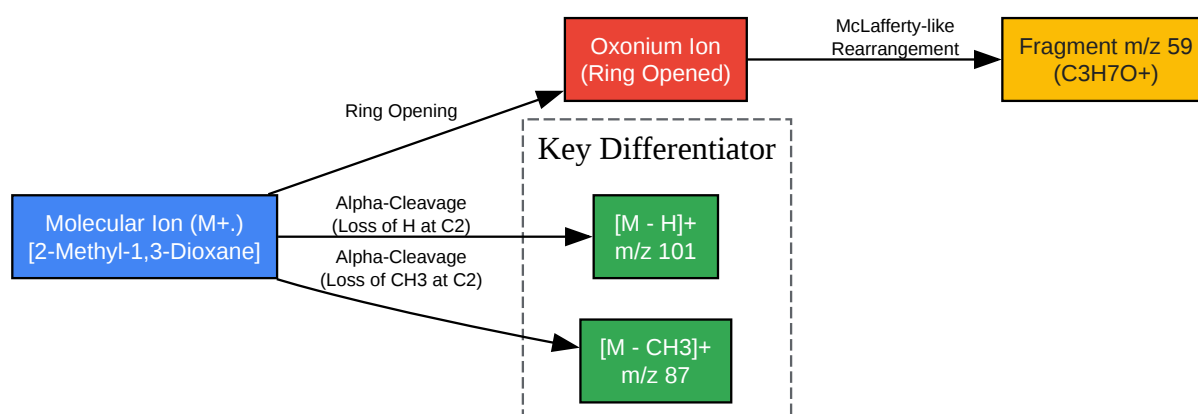

[Click to download full resolution via product page](#)

Caption: Primary fragmentation pathways for 2-methyl-1,3-dioxane, highlighting the stability of C2-cleavage products.

1,4-Dioxane Fragmentation Logic

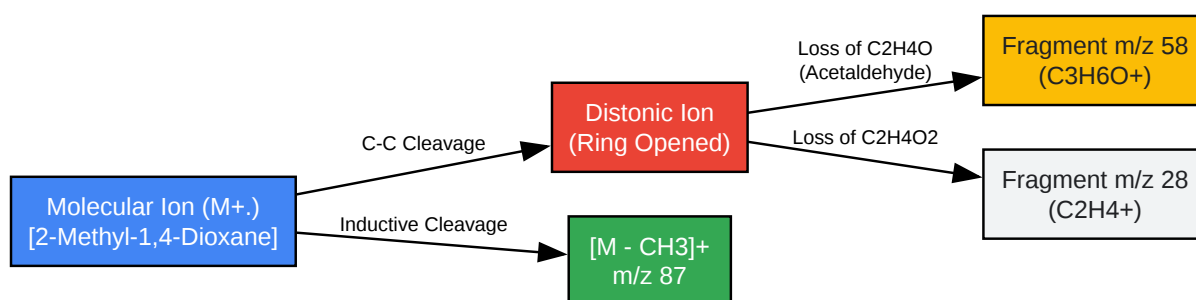

[Click to download full resolution via product page](#)

Caption: Fragmentation of 2-methyl-1,4-dioxane showing characteristic ring disintegration patterns.

Experimental Protocol: Self-Validating GC-MS Workflow

To reliably distinguish these isomers, a standardized GC-MS protocol is required. This protocol includes a "System Suitability" step to ensure the instrument can resolve the subtle spectral differences.

Protocol Parameters[3][4][5][6][7]

- Instrument: Single Quadrupole GC-MS (e.g., Agilent 5977 or Thermo ISQ).
- Column: Non-polar capillary column (e.g., DB-5ms or TG-624), 30 m x 0.25 mm, 0.25 μ m film.
- Carrier Gas: Helium at 1.0 mL/min (constant flow).
- Ionization: Electron Ionization (EI) at 70 eV.[3][4]

Step-by-Step Workflow

- Sample Preparation:
 - Dissolve sample in Dichloromethane (DCM) to a concentration of 100 μ g/mL.

- Validation Check: Ensure solvent peak does not co-elute with target dioxane (DCM elutes early).
- GC Method Setup:
 - Inlet: Split 20:1, 250°C.
 - Oven Program: 40°C (hold 2 min)

10°C/min to 150°C

25°C/min to 280°C.
 - Rationale: The low initial temperature and slow ramp are critical for separating cis and trans isomers, which may differ in boiling point by only 1-2°C.
- Data Acquisition:
 - Scan Mode: Full Scan (m/z 35-300).
 - SIM Mode (Optional): If quantifying, monitor m/z 87, 101, 58.
- System Suitability (The "Trust" Step):
 - Inject a mixture of known cis and trans isomers.
 - Requirement: Baseline resolution () between isomers.
 - Spectral Check: The trans isomer peak must show a higher ratio of than the cis peak.

Analytical Workflow Diagram

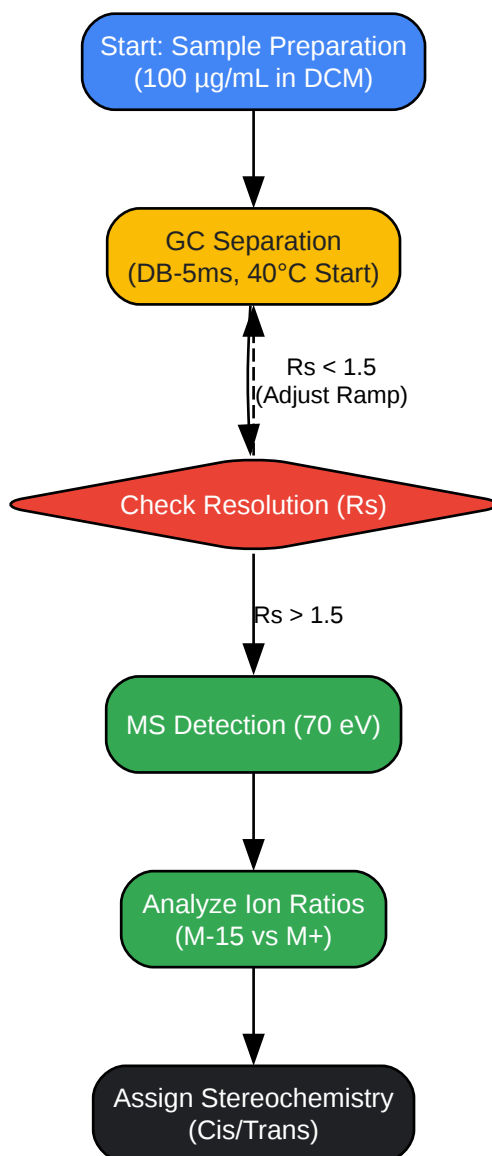

[Click to download full resolution via product page](#)

Caption: Logical workflow for the separation and identification of dioxane stereoisomers.

Data Summary: Diagnostic Ions

The following table summarizes the key ions used to distinguish the species.

Compound Class	Key Ion (m/z)	Origin	Relative Abundance Note
2-Methyl-1,3-dioxane	101		Strong (stable oxonium).
	87	Moderate.	
4-Methyl-1,3-dioxane	102		Visible.
	87	Base peak (often).	
2-Methyl-1,4-dioxane	58		Characteristic RDA fragment.
	87	Present, but competes with ring fragmentation.	
trans-2,4,6-Trimethyl	113		Very High (Relief of axial strain).
cis-2,4,6-Trimethyl	113		Lower (Stable equatorial conformation).

References

- NIST Mass Spectrometry Data Center. Mass Spectrum of 2-methyl-1,3-dioxane. National Institute of Standards and Technology. Available at: [\[Link\]](#)
- Albu, T. V., et al. (2006). Hybrid density functional theory study of fragment ions generated during mass spectrometry of 1,3-dioxane derivatives. Rapid Communications in Mass Spectrometry. Available at: [\[Link\]](#)

Need Custom Synthesis?

BenchChem offers custom synthesis for rare earth carbides and specific isotopic labeling.

Email: info@benchchem.com or [Request Quote Online](#).

Sources

- [1. Hybrid density functional theory study of fragment ions generated during mass spectrometry of 1,3-dioxane derivatives - PubMed \[pubmed.ncbi.nlm.nih.gov\]](#)
- [2. Radical cations of cis- and trans-1,3-di- and 1,3,5-trimethylcyclohexanes. Matrix influence on two nearly degenerate SOMOs - Journal of the Chemical Society, Perkin Transactions 2 \(RSC Publishing\) \[pubs.rsc.org\]](#)
- [3. \[arkat-usa.org\]\(http://arkat-usa.org\) \[arkat-usa.org\]](#)
- [4. \[glenjackson.faculty.wvu.edu\]\(http://glenjackson.faculty.wvu.edu\) \[glenjackson.faculty.wvu.edu\]](#)
- To cite this document: BenchChem. [Comparative Guide: Mass Spectrometry Fragmentation of Methyl-Substituted Dioxanes]. BenchChem, [2026]. [Online PDF]. Available at: [\[https://www.benchchem.com/product/b8663068/docs#comparative-guide-mass-spectrometry-fragmentation-of-methyl-substituted-dioxanes\]](https://www.benchchem.com/product/b8663068/docs#comparative-guide-mass-spectrometry-fragmentation-of-methyl-substituted-dioxanes)

Disclaimer & Data Validity:

The information provided in this document is for Research Use Only (RUO) and is strictly not intended for diagnostic or therapeutic procedures. While BenchChem strives to provide accurate protocols, we make no warranties, express or implied, regarding the fitness of this product for every specific experimental setup.

Technical Support: The protocols provided are for reference purposes. Unsure if this reagent suits your experiment?

Need Industrial/Bulk Grade? [Request Custom Synthesis Quote](#)

BenchChem

Our mission is to be the trusted global source of essential and advanced chemicals, empowering scientists and researchers to drive progress in science and industry.

Contact

Address: 3281 E Guasti Rd
Ontario, CA 91761, United States
Phone: (601) 213-4426
Email: info@benchchem.com

Contact our Ph.D. Support Team for a compatibility check