

# Application Note: High-Fidelity Synthesis of MHPOBC-Class Chiral Dopants

**Author:** BenchChem Technical Support Team. **Date:** April 2026

## Compound of Interest

**Compound Name:** 4-(1-Methylheptyloxycarbonyl)phenol

**Cat. No.:** B8657604

[Get Quote](#)

## Executive Summary & Scientific Rationale

This guide details the protocol for synthesizing high-performance chiral dopants by coupling **4-(1-Methylheptyloxycarbonyl)phenol** (hereafter referred to as Fragment B) with mesogenic carboxylic acids.

The starting material, a chiral ester of 4-hydroxybenzoic acid, serves as the "chiral tail" anchor. Its structural significance lies in the 1-methylheptyl group (derived from 2-octanol). The proximity of the chiral center to the rigid core maximizes the Helical Twisting Power (HTP) by restricting conformational freedom, a critical parameter for inducing cholesteric (N) or ferroelectric smectic C (SmC\*) phases in liquid crystal hosts.

**Mechanistic Insight:** We utilize an Acid Chloride-Mediated Esterification rather than standard carbodiimide (DCC) coupling. While DCC is milder, the acid chloride route is preferred for liquid crystals to eliminate the risk of N-acylurea byproducts, which are notoriously difficult to remove from mesogenic materials and can suppress phase transition temperatures.

## Material Specifications & Pre-Validation

Before initiating synthesis, the enantiomeric purity of the starting phenol must be validated, as HTP is linearly dependent on optical purity.

**Table 1: Key Reagents and Specifications**

Component	Role	Specification	Critical Parameter
4-(1-Methylheptyloxycarbonyl)phenol	Chiral Precursor (Fragment B)	>98% purity, >99% ee	Moisture Content <0.1% (Interferes with coupling)
4'-Octyloxybiphenyl-4-carboxylic acid	Mesogenic Core (Fragment A)	>98% purity	Alkyl chain length defines smectic phase stability
Thionyl Chloride (SOCl <sub>2</sub> )	Chlorinating Agent	Reagent Grade, distilled	Freshly distilled to remove HCl/SO <sub>2</sub>
Pyridine / Triethylamine	Base / Catalyst	Anhydrous	Acts as HCl scavenger
Dichloromethane (DCM)	Solvent	Anhydrous	Stabilized with amylene (avoid ethanol stabilizer)

## Synthetic Protocol: Convergent Coupling

This protocol describes the synthesis of 4'-(1-methylheptyloxycarbonyl)phenyl 4-octyloxybiphenyl-4-carboxylate (an MHPOBC analogue), a standard high-HTP dopant.

### Phase A: Activation of the Mesogenic Core (Acid Chloride Formation)

Objective: Convert the stable biphenyl acid into the reactive acid chloride.

- Setup: Equip a 250 mL round-bottom flask (RBF) with a magnetic stir bar, reflux condenser, and a CaCl<sub>2</sub> drying tube (or N<sub>2</sub> inlet).
- Charge: Add 10.0 mmol of 4'-octyloxybiphenyl-4-carboxylic acid.

- Reagent Addition: Add 15 mL (excess) of Thionyl Chloride (SOCl<sub>2</sub>). Add 2 drops of anhydrous DMF (Dimethylformamide) as a catalyst.
  - Mechanism:[1][2][3] DMF forms a Vilsmeier-Haack type intermediate, significantly accelerating the reaction.
- Reaction: Reflux at 75°C for 3–4 hours.
  - Endpoint Check: The solution should turn from a suspension to a clear yellow liquid.
- Workup: Remove excess SOCl<sub>2</sub> via rotary evaporation under reduced pressure.
  - Caution: Add dry toluene (2 x 10 mL) and re-evaporate to azeotropically remove trace SOCl<sub>2</sub>.
- Product: Yields 4'-octyloxybiphenyl-4-carbonyl chloride (Solid yellow residue). Use immediately in Phase B.

## Phase B: Esterification (The Coupling)

Objective: Covalent attachment of the Chiral Phenol (Fragment B) to the Activated Core.

- Solvation: Dissolve the crude acid chloride (from Phase A) in 20 mL anhydrous DCM.
- Preparation of Phenol: In a separate flask, dissolve 10.0 mmol of **4-(1-Methylheptyloxycarbonyl)phenol** and 12.0 mmol of Pyridine in 15 mL anhydrous DCM.
- Addition: Cool the Phenol/Pyridine solution to 0°C (ice bath). Dropwise add the Acid Chloride solution over 30 minutes.
  - Why 0°C? Controls the exotherm and prevents ester hydrolysis or side reactions.
- Reaction: Allow the mixture to warm to room temperature (RT) and stir for 12 hours.
  - Visual Cue: A white precipitate (Pyridinium Hydrochloride) will form, indicating successful coupling.
- Quench: Pour the reaction mixture into 100 mL ice-cold water and stir for 10 minutes.

## Phase C: Purification & Isolation

Objective: Remove unreacted phenol and pyridinium salts to achieve electronic-grade purity.

- Extraction: Separate the organic layer. Extract the aqueous layer with DCM (2 x 20 mL). Combine organic phases.[1]
- Washing (Critical for LCs):
  - Wash 1: 1M HCl (Removes residual Pyridine).
  - Wash 2: Sat. NaHCO<sub>3</sub> (Removes unreacted Acid/Phenol).
  - Wash 3: Brine (Drying).[4]
- Drying: Dry over anhydrous MgSO<sub>4</sub>, filter, and concentrate to dryness.
- Recrystallization:
  - Dissolve the crude solid in minimal boiling Ethanol.
  - Allow to cool slowly to RT, then to 4°C.
  - Note: If oiling occurs, use an Ethanol/Hexane (1:1) mixture.
- Final Yield: Expect 70–85% as white/off-white needles.

## Visualization of Workflow

The following diagram illustrates the convergent synthesis pathway and critical control points.

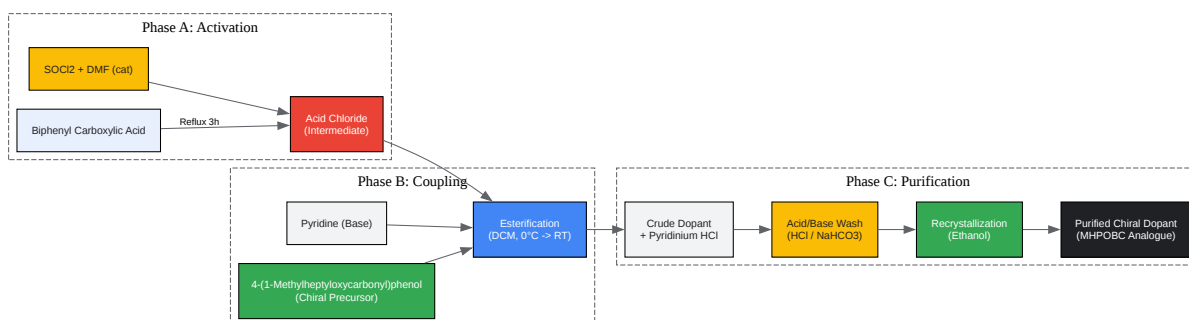

[Click to download full resolution via product page](#)

Caption: Convergent synthesis workflow for MHPOBC-class dopants. Color codes indicate reaction stages: Blue (Reaction), Red (Reactive Intermediate), Green (Key Product).

## Quality Control & Characterization

To validate the synthesized dopant for use in liquid crystal formulations, the following analytical battery is required.

### Table 2: Analytical Validation Metrics

Technique	Parameter	Acceptance Criteria
<sup>1</sup> H-NMR (CDCl <sub>3</sub> )	Structural Integrity	Peaks at δ 8.1–8.3 (Ar-H ortho to ester), δ 5.2 (Chiral methine). No aldehyde peaks.
HPLC (Chiral Column)	Enantiomeric Excess (ee)	>99% ee. Use Chiralcel OD-H column, Hexane/IPA mobile phase.
DSC (Differential Scanning Calorimetry)	Phase Transitions	Sharp peaks for Cryst -> SmC* -> SmA -> Iso. Broad peaks indicate impurities.
POM (Polarized Optical Microscopy)	Texture Analysis	Characteristic "fingerprint" texture in cholesteric phase; Schlieren texture in SmC*.

## Helical Twisting Power (HTP) Measurement

The HTP (

) is the defining metric for these dopants.[5][6]

- Doping: Prepare a mixture of 1.0 wt% dopant in a standard nematic host (e.g., 5CB or E7).
- Pitch Measurement: Measure the helical pitch ( ) using the Grandjean-Cano wedge method.
- Calculation:

where

is concentration and

is enantiomeric purity.

- Target: Expect

for this class of dopants.[7]

## Troubleshooting Guide

Issue	Probable Cause	Corrective Action
Low Yield (<50%)	Hydrolysis of Acid Chloride	Ensure toluene azeotrope step is complete; use fresh anhydrous DCM.
Oily Product	Residual Solvent / Impurities	Recrystallize from Ethanol/Hexane (1:1) or perform column chromatography (Silica, Hexane:EtOAc 9:1).
Low HTP Value	Racemization of Chiral Center	Avoid heating the phenol above 40°C in basic conditions. Verify starting material optical rotation.
Cloudy Melt (DSC)	Inorganic Salts	Incomplete aqueous washing. Re-dissolve in DCM and wash with water until neutral pH.

## References

- Duda, Ł., et al. (2019).[8][9] Helical twisting power and compatibility in twisted nematic phase of new chiral liquid crystalline dopants. Liquid Crystals.[1][5][7][8][9][10][11] [Link](#)
- Zhang, J., et al. (2018). Novel planar chiral dopants with high helical twisting power and structure-dependent functions. Journal of Materials Chemistry C. [Link](#)
- Goodby, J. W., et al. (2010). Liquid-crystalline aromatic–aliphatic copolyester bioresorbable polymers. ResearchGate. [Link](#)
- Chisso Corporation. (2004). Chiral compounds as dopants for liquid crystals. EP1380567A1. [Link](#)
- Kricheldorf, H. R. (2011). Mechanistic Studies of LCP Synthesis. Polymers (MDPI). [Link](#)

**Need Custom Synthesis?**

BenchChem offers custom synthesis for rare earth carbides and specific isotopic labeling.

Email: [info@benchchem.com](mailto:info@benchchem.com) or [Request Quote Online](#).

## Sources

- [1. mdpi.com](https://www.mdpi.com) [[mdpi.com](https://www.mdpi.com)]
- [2. chemrxiv.org](https://chemrxiv.org) [[chemrxiv.org](https://chemrxiv.org)]
- [3. Enantioselective Synthesis of Biphenols from 1,4-Diketones by Traceless Central-to-Axial Chirality Exchange - PMC](#) [[pmc.ncbi.nlm.nih.gov](https://pubmed.ncbi.nlm.nih.gov)]
- [4. air.unimi.it](https://air.unimi.it) [[air.unimi.it](https://air.unimi.it)]
- [5. researchgate.net](https://www.researchgate.net) [[researchgate.net](https://www.researchgate.net)]
- [6. BJOC - 4,6-Diaryl-5,5-difluoro-1,3-dioxanes as chiral dopants for liquid crystal compositions](#) [[beilstein-journals.org](https://beilstein-journals.org)]
- [7. Novel planar chiral dopants with high helical twisting power and structure-dependent functions - Journal of Materials Chemistry C \(RSC Publishing\)](#) [[pubs.rsc.org](https://pubs.rsc.org)]
- [8. tandf.figshare.com](https://tandf.figshare.com) [[tandf.figshare.com](https://tandf.figshare.com)]
- [9. semanticscholar.org](https://www.semanticscholar.org) [[semanticscholar.org](https://www.semanticscholar.org)]
- [10. Precisely Tuning Helical Twisting Power via Photoisomerization Kinetics of Dopants in Chiral Nematic Liquid Crystals - PubMed](#) [[pubmed.ncbi.nlm.nih.gov](https://pubmed.ncbi.nlm.nih.gov)]
- [11. EP1380567A1 - Chiral compounds as dopants for liquid crystals - Google Patents](#) [[patents.google.com](https://patents.google.com)]
- To cite this document: BenchChem. [Application Note: High-Fidelity Synthesis of MHPOBC-Class Chiral Dopants]. BenchChem, [2026]. [Online PDF]. Available at: [<https://www.benchchem.com/product/b8657604/docs#application-note-high-fidelity-synthesis-of-mhpobc-class-chiral-dopants>]

---

**Disclaimer & Data Validity:**

The information provided in this document is for Research Use Only (RUO) and is strictly not intended for diagnostic or therapeutic procedures. While BenchChem strives to provide

accurate protocols, we make no warranties, express or implied, regarding the fitness of this product for every specific experimental setup.

**Technical Support:** The protocols provided are for reference purposes. Unsure if this reagent suits your experiment?

**Need Industrial/Bulk Grade?** [Request Custom Synthesis Quote](#)

## BenchChem

Our mission is to be the trusted global source of essential and advanced chemicals, empowering scientists and researchers to drive progress in science and industry.

### Contact

Address: 3281 E Guasti Rd

Ontario, CA 91761, United States

Phone: (601) 213-4426

Email: [info@benchchem.com](mailto:info@benchchem.com)

[Contact our Ph.D. Support Team for a compatibility check](#)