

Application Notes and Protocols: *t*-Butylammonium Chloride in Organocatalysis

Author: BenchChem Technical Support Team. **Date:** May 2026

Compound of Interest

Compound Name: *t*-Butylammonium chloride

Cat. No.: B8654595

[Get Quote](#)

For Researchers, Scientists, and Drug Development Professionals

This document provides detailed application notes and protocols for the use of **tert-butylammonium chloride** ($t\text{-BuNH}_3\text{Cl}$) and its tetraalkylammonium analogue, tetrabutylammonium chloride (TBAC), in various organocatalytic reactions. These salts have demonstrated utility as versatile catalysts, primarily functioning as phase-transfer catalysts and, in some contexts, as hydrogen-bonding catalysts. The following sections detail their application in the synthesis of valuable organic scaffolds, including 2-amino-4H-chromenes and ethers via Williamson synthesis. Experimental protocols, quantitative data, and mechanistic diagrams are provided to facilitate the practical application of these catalysts in a research and development setting.

Synthesis of 2-Amino-4H-chromene Derivatives via Multi-component Reaction

Tetrabutylammonium chloride (TBAC) has been effectively employed as a catalyst for the one-pot, three-component synthesis of 2-amino-4H-chromenes.^{[1][2]} This reaction proceeds through the condensation of an aldehyde, an activated methylene compound (malononitrile), and a phenol (α - or β -naphthol). The methodology is notable for its operational simplicity, high

yields, and short reaction times, offering an environmentally benign approach by utilizing water as a solvent or solvent-free conditions.^{[1][2]}

Reaction Scheme

General Reaction for the Synthesis of 2-Amino-4H-chromenes

Mechanism of Catalysis

In this reaction, tetrabutylammonium chloride is proposed to act as a phase-transfer catalyst, facilitating the deprotonation of the phenol and the subsequent cascade of reactions in the aqueous medium. The lipophilic tetrabutylammonium cation pairs with the phenoxide anion, increasing its nucleophilicity and solubility in the organic phase where the reaction with the Knoevenagel adduct (formed from the aldehyde and malononitrile) occurs.

Mechanism of TBAC-Catalyzed Synthesis of 2-Amino-4H-chromenes

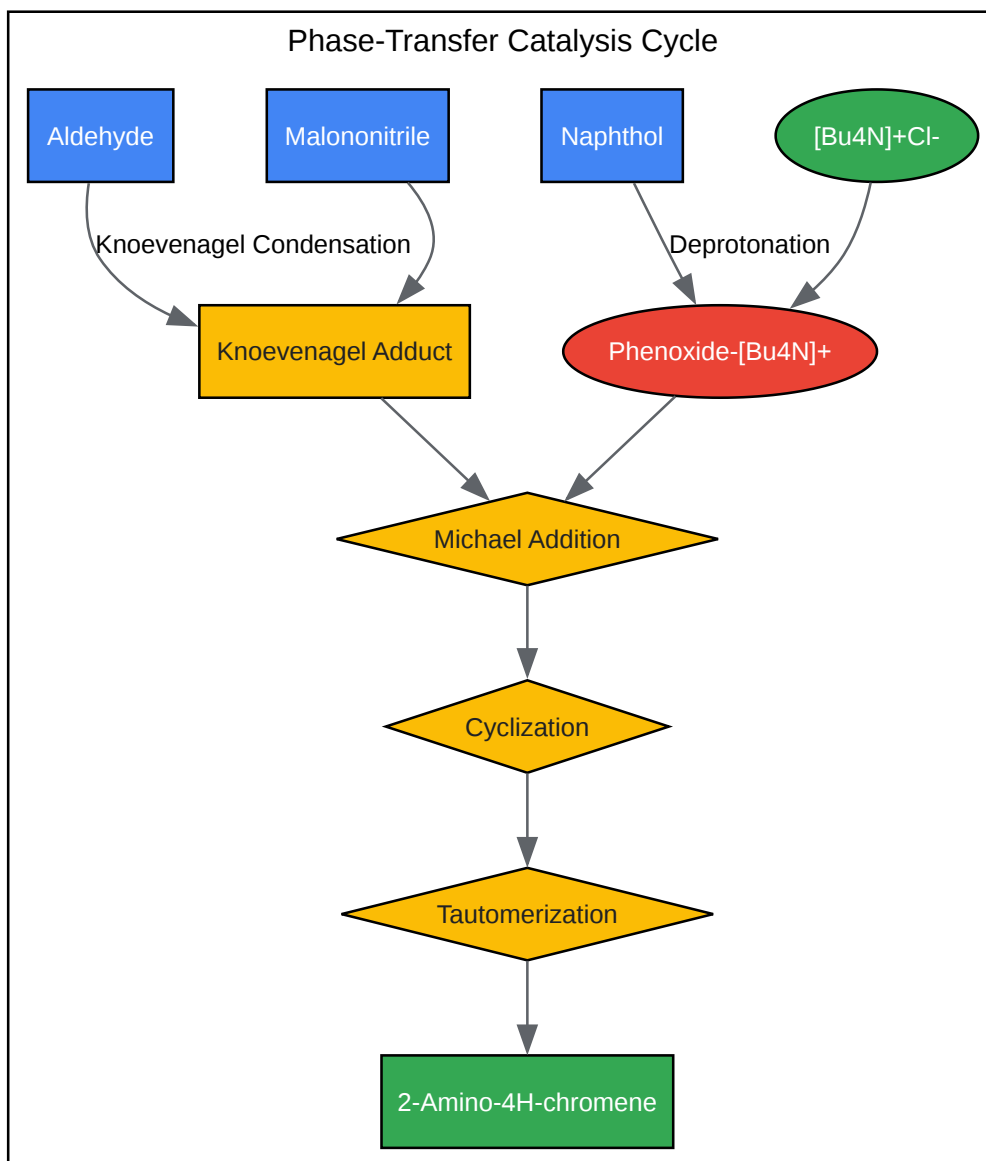

[Click to download full resolution via product page](#)

Caption: Catalytic cycle for the synthesis of 2-amino-4H-chromenes.

Quantitative Data

The following table summarizes the results for the synthesis of various 2-amino-4H-chromene derivatives using 10 mol% of tetrabutylammonium chloride (TBAC) as the catalyst. The reactions were carried out in water (Method A) or under solvent-free conditions (Method B).[1]

Entry	Aldehyde (Ar)	Method	Time (min)	Yield (%) ^[1]
1	C ₆ H ₅	A	15	94
2	C ₆ H ₅	B	10	96
3	4-ClC ₆ H ₄	A	10	96
4	4-ClC ₆ H ₄	B	8	98
5	4-NO ₂ C ₆ H ₄	A	8	98
6	4-NO ₂ C ₆ H ₄	B	5	98
7	4-CH ₃ OC ₆ H ₄	A	20	92
8	4-CH ₃ OC ₆ H ₄	B	15	94
9	3-NO ₂ C ₆ H ₄	A	10	95
10	3-NO ₂ C ₆ H ₄	B	8	96

Experimental Protocol

Method A: Reaction in Water

- To a round-bottom flask, add the aldehyde (1 mmol), malononitrile (1 mmol), α -naphthol (1 mmol), and tetrabutylammonium chloride (0.1 mmol, 10 mol%).
- Add 5 mL of water to the flask.
- Stir the mixture vigorously at room temperature.
- Monitor the reaction progress by Thin Layer Chromatography (TLC).
- Upon completion, the solid product is collected by filtration.
- Wash the solid with cold water.

- Recrystallize the product from ethanol to afford the pure 2-amino-4H-chromene.

Method B: Solvent-Free Reaction

- In a mortar, grind a mixture of the aldehyde (1 mmol), malononitrile (1 mmol), α -naphthol (1 mmol), and tetrabutylammonium chloride (0.1 mmol, 10 mol%).
- Transfer the mixture to a reaction vessel and heat at 80 °C.
- Monitor the reaction progress by TLC.
- After completion, cool the reaction mixture to room temperature.
- Add ethanol to the solidified mass and stir.
- Collect the solid product by filtration and wash with cold ethanol.
- Recrystallize from ethanol to obtain the pure product.

Experimental Workflow for 2-Amino-4H-chromene Synthesis

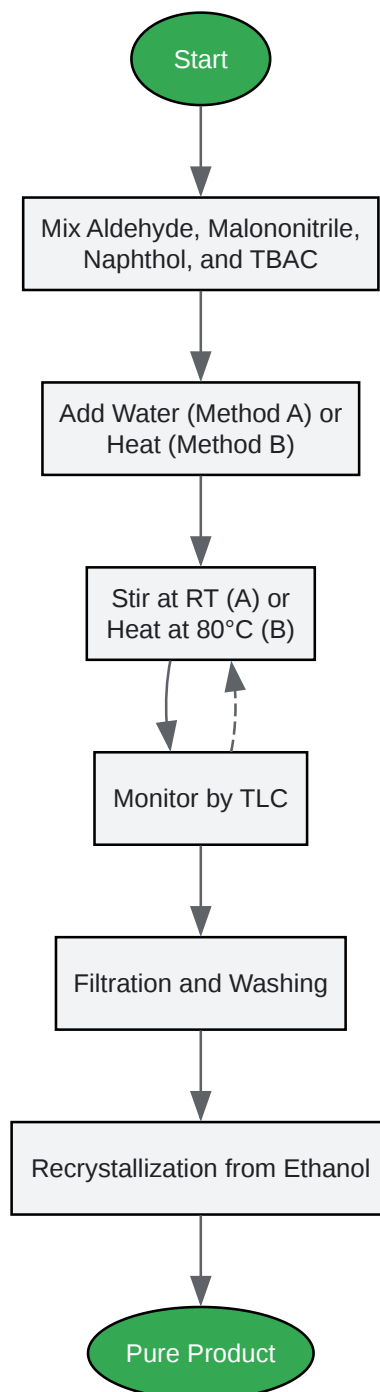

[Click to download full resolution via product page](#)

Caption: General experimental workflow for the synthesis of 2-amino-4H-chromenes.

Williamson Ether Synthesis under Phase-Transfer Catalysis

The Williamson ether synthesis, a classical method for the preparation of ethers, can be significantly improved by the use of phase-transfer catalysts such as tetrabutylammonium chloride (TBAC). This is particularly beneficial when one of the reactants is soluble in an organic phase and the other (the alkoxide or phenoxide) is in an aqueous phase. TBAC facilitates the transfer of the nucleophile across the phase boundary, accelerating the S_N2 reaction.

Reaction Scheme

Synthesis of 4-Methoxyphenyl Benzyl Ether

Mechanism of Catalysis

The tetrabutylammonium cation forms a lipophilic ion pair with the phenoxide anion in the aqueous phase. This ion pair is soluble in the organic phase, where it can react with the alkyl halide. The resulting halide anion is then transported back to the aqueous phase by the catalyst, completing the catalytic cycle.

Mechanism of Phase-Transfer Catalyzed Williamson Ether Synthesis

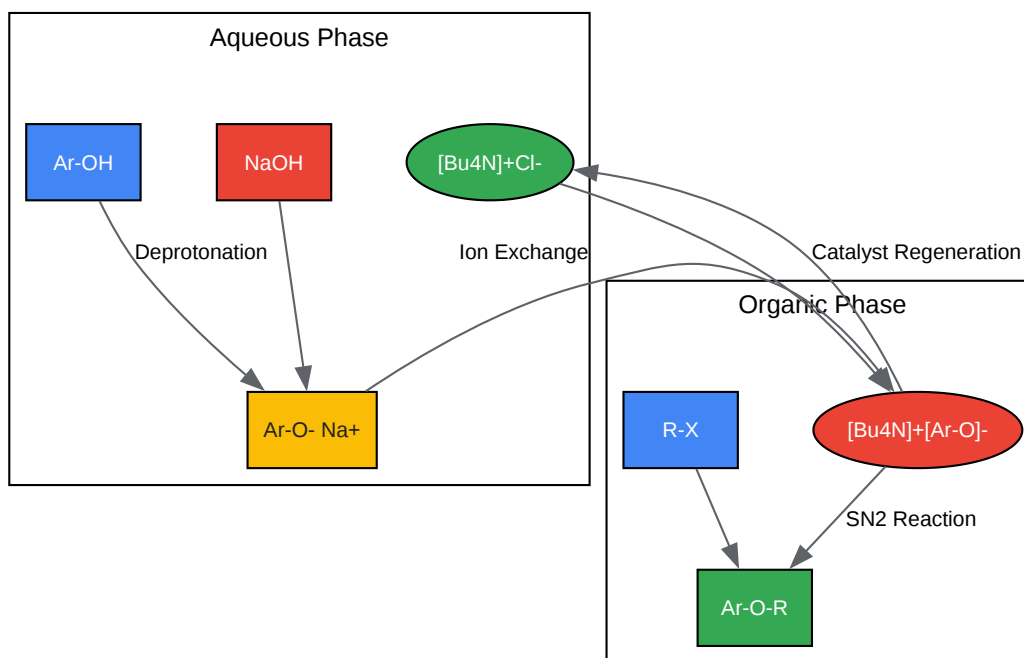

[Click to download full resolution via product page](#)

Caption: Phase-transfer catalytic cycle for the Williamson ether synthesis.

Quantitative Data

The following table presents representative data for the phase-transfer catalyzed Williamson ether synthesis.

Entry	Phenol	Alkyl Halide	Catalyst (mol%)	Solvent	Temp (°C)	Time (h)	Yield (%)
1	4-Methoxyphenol	Benzyl chloride	TBAC (5)	Toluene/H ₂ O	80	4	~95 (estimated)
2	Phenol	n-Butyl bromide	TBAB (5)	Dichloromethane/H ₂ O	Reflux	2	98
3	2-Naphthol	Ethyl iodide	TBAC (10)	Chlorobenzene/H ₂ O	90	6	92

Note: The yield for entry 1 is an estimation based on similar phase-transfer catalyzed etherifications, as specific data for this exact reaction with TBAC was not available in the cited literature.

Experimental Protocol

Synthesis of 4-Methoxyphenyl Benzyl Ether

- In a round-bottom flask equipped with a reflux condenser and a magnetic stirrer, dissolve 4-methoxyphenol (10 mmol) in 20 mL of a 10% aqueous sodium hydroxide solution.
- Add tetrabutylammonium chloride (0.5 mmol, 5 mol%) to the aqueous solution.
- Add benzyl chloride (10 mmol) dissolved in 20 mL of toluene to the reaction mixture.
- Heat the biphasic mixture to 80 °C and stir vigorously for 4 hours.
- Monitor the reaction by TLC.
- After completion, cool the reaction to room temperature and separate the organic layer.
- Wash the organic layer with water and then with brine.

- Dry the organic layer over anhydrous sodium sulfate, filter, and concentrate under reduced pressure.
- Purify the crude product by column chromatography on silica gel (eluent: hexane/ethyl acetate) to obtain 4-methoxyphenyl benzyl ether.

Experimental Workflow for Williamson Ether Synthesis

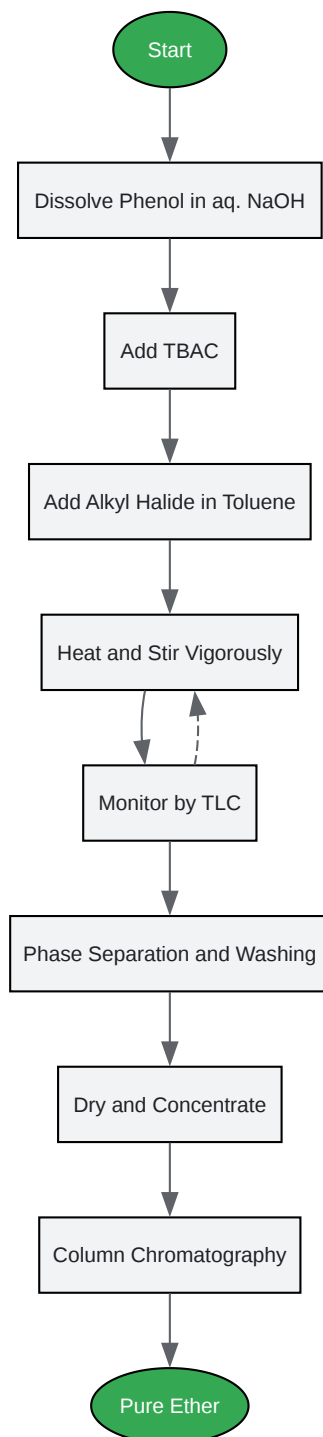

[Click to download full resolution via product page](#)

Caption: General experimental workflow for the phase-transfer catalyzed Williamson ether synthesis.

Concluding Remarks

Tetrabutylammonium chloride is a readily available, inexpensive, and efficient organocatalyst for promoting reactions between immiscible reactants. Its application in the synthesis of 2-amino-4H-chromenes and ethers demonstrates its utility in facilitating synthetically important transformations under mild and often environmentally friendly conditions. The protocols and data presented herein provide a foundation for the application of **t-butylammonium chloride** and its analogues in a variety of organocatalytic processes relevant to pharmaceutical and materials science research. Further exploration of its role in other catalytic systems, including those where it may act as a hydrogen-bond donor, is an area of ongoing interest.

Need Custom Synthesis?

BenchChem offers custom synthesis for rare earth carbides and specific isotopic labeling.

Email: info@benchchem.com or [Request Quote Online](#).

References

- 1. cactus.utahtech.edu [cactus.utahtech.edu]
- 2. jk-sci.com [jk-sci.com]
- To cite this document: BenchChem. [Application Notes and Protocols: t-Butylammonium Chloride in Organocatalysis]. BenchChem, [2026]. [Online PDF]. Available at: [<https://www.benchchem.com/product/b8654595/docs#application-notes-and-protocols-t-butylammonium-chloride-in-organocatalysis>]

Disclaimer & Data Validity:

The information provided in this document is for Research Use Only (RUO) and is strictly not intended for diagnostic or therapeutic procedures. While BenchChem strives to provide accurate protocols, we make no warranties, express or implied, regarding the fitness of this product for every specific experimental setup.

Technical Support: The protocols provided are for reference purposes. Unsure if this reagent suits your experiment?

Need Industrial/Bulk Grade? [Request Custom Synthesis Quote](#)

BenchChem

Our mission is to be the trusted global source of essential and advanced chemicals, empowering scientists and researchers to drive progress in science and industry.

Contact

Address: 3281 E Guasti Rd
Ontario, CA 91761, United States
Phone: (601) 213-4426
Email: info@benchchem.com

[Contact our Ph.D. Support Team for a compatibility check](#)