

Application Note: Catalytic Synthesis of 4-Fluorophenylethylsulfone Derivatives

Author: BenchChem Technical Support Team. **Date:** May 2026

Compound of Interest

Compound Name: 4-Fluorophenylethylsulfone

Cat. No.: B8654246

[Get Quote](#)

Executive Summary & Scientific Rationale

The **4-fluorophenylethylsulfone** moiety represents a critical pharmacophore in modern medicinal chemistry. The specific combination of the electron-withdrawing fluorine atom (para-position) and the ethyl sulfone group offers a dual advantage:

- **Metabolic Stability:** The fluorine atom blocks the metabolically vulnerable para-position of the phenyl ring (preventing P450-mediated hydroxylation), while the sulfone () acts as a bioisostere for carbonyls or sulfonamides with superior hydrolytic stability.
- **Electronic Modulation:** The strong electron-withdrawing nature of the sulfone ($\sigma_p \approx 0.68$ LogP) of the scaffold.

This guide details three distinct catalytic protocols for synthesizing this target from 1-bromo-4-fluorobenzene and sodium ethanesulfinate. We prioritize the Palladium-Catalyzed Cross-Coupling (Method A) for its reliability and functional group tolerance, while providing Copper-Catalyzed (Method B) and Photoredox (Method C) alternatives for specific process constraints.

Comparative Analysis of Catalytic Routes

The following table summarizes the strategic trade-offs for each methodology.

Feature	Method A: Pd-Catalysis (Recommended)	Method B: Cu-Catalysis (Cost-Effective)	Method C: Photoredox/Ni (Mild/Green)
Catalyst System	/ Xantphos	/ L-Proline (or DMEDA)	/
Key Reagent	Sodium Ethanesulfinate	Sodium Ethanesulfinate	Sodium Ethanesulfinate
Temperature	80–100 °C	90–120 °C	Room Temperature (25 °C)
Reaction Time	4–12 Hours	12–24 Hours	18–24 Hours
Yield (Typical)	85–95%	70–85%	60–80%
Scalability	High (Kg scale proven)	High (Industrial preferred)	Low/Medium (Flow required)
Primary Risk	Cost of Pd/Ligand	High temp / Solubility	Light penetration / Catalyst cost

Method A: Palladium-Catalyzed Cross-Coupling (The "Cacchi" Type)

This protocol is the "Gold Standard" for research-scale synthesis due to its high reproducibility. It utilizes the Xantphos ligand, whose wide bite angle (

) facilitates the reductive elimination of the sulfone product.

Mechanistic Pathway

The reaction proceeds via a

cycle. The critical step is the transmetalation of the sulfinate anion to the arylpalladium(II) species, followed by reductive elimination to form the

bond.

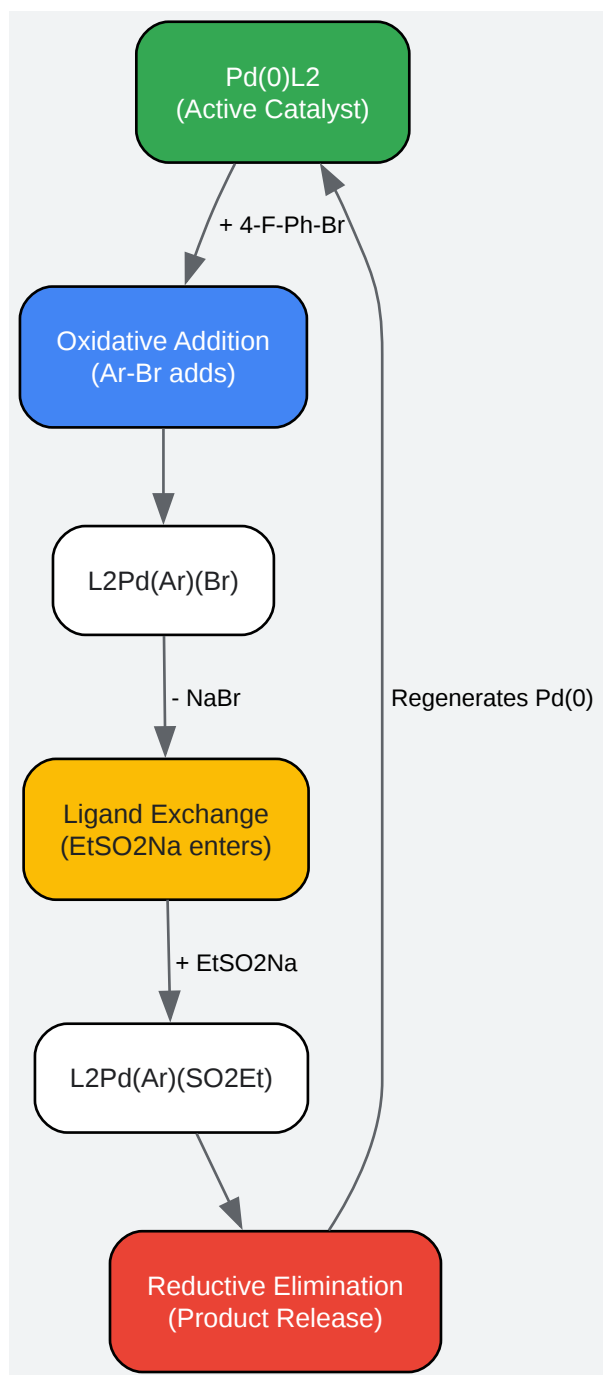

[Click to download full resolution via product page](#)

Figure 1: Catalytic cycle for Pd-catalyzed sulfonylation. The wide bite angle of Xantphos destabilizes Complex 2, accelerating reductive elimination.

Detailed Protocol

Reagents:

- 1-Bromo-4-fluorobenzene ()
- Sodium Ethanesulfinate ()
- ()
- Xantphos ()
- () [Optional but enhances rate]
- Solvent: 1,4-Dioxane or Toluene (Anhydrous, degassed)

Step-by-Step Procedure:

- Preparation: In a glovebox or under Argon flow, charge a heavy-walled pressure vial with (,) and Xantphos (,).

- Solvation: Add

of anhydrous 1,4-dioxane. Stir at RT for 5 minutes to pre-form the active catalyst complex (solution turns deep purple/orange).

- Substrate Addition: Add 1-Bromo-4-fluorobenzene (

,

), Sodium Ethanesulfinate (

,

), and

(

,

).

- Reaction: Seal the vial with a Teflon-lined cap. Heat to 100 °C in an aluminum block for 6–12 hours.
- Monitoring: Monitor via TLC (30% EtOAc/Hexanes) or LC-MS. The product (sulfone) is significantly more polar than the aryl bromide.
- Work-up: Cool to RT. Filter through a pad of Celite to remove inorganic salts. Wash the pad with EtOAc.
- Purification: Concentrate the filtrate. Purify via flash column chromatography (Gradient: 0–20% EtOAc in Hexanes).

Validation Check:

- NMR: Look for a shift from

(Ar-Br) to

(Ar-SO₂). The electron-withdrawing sulfone deshields the fluorine.

Method B: Copper-Catalyzed Sulfonylation (The "Ma" Type)

Ideal for cost-sensitive applications where Palladium contamination must be avoided. This method utilizes an Ullmann-type coupling mechanism facilitated by amino-acid ligands.

Reagents:

- 1-Bromo-4-fluorobenzene ()
- Sodium Ethanesulfinate ()
- ()
- L-Proline ()
- () - Essential to deprotonate proline
- Solvent: DMSO (Required for solubility of sulfonates)

Protocol Highlights:

- Mixing: Combine , L-Proline, and in DMSO under Argon. Stir until a homogeneous blue/green solution forms (Cu-ligand complex).
- Reaction: Add the aryl bromide and sulfinate.

- Heat: This reaction requires higher energy. Heat to 110–120 °C for 18–24 hours.
- Work-up (Critical): DMSO is difficult to remove. Dilute the reaction mixture with water (volume) and extract exhaustively with EtOAc (). Wash organic layer with brine to remove residual DMSO.

Method C: Photoredox/Nickel Dual Catalysis

This emerging method allows the reaction to proceed at Room Temperature, preventing thermal decomposition of sensitive substrates.

Mechanism: A photocatalyst (Ir or Ru) acts as a Single Electron Transfer (SET) agent to modulate the oxidation state of a Nickel co-catalyst, allowing it to undergo oxidative addition to the aryl halide under mild conditions.

Protocol:

- Catalysts:
(
) and
(
) with dtbbpy ligand.
- Light Source: Blue LED (
,
).
- Setup: The reaction must be degassed thoroughly (freeze-pump-thaw x3) as quenches the excited state of the photocatalyst.
- Advantage: This method is strictly recommended if the "Ethyl" group is substituted with a thermally labile group, though for standard ethyl sulfones, Method A is more economical.

Experimental Workflow & Safety Diagram



[Click to download full resolution via product page](#)

Figure 2: Generalized experimental workflow for thermal catalytic sulfonylation.

Safety & Handling Notes

- Sodium Ethanesulfinate: Hygroscopic. Store in a desiccator. Wet reagents will stall the Pd-catalyst.
- Pressure: Reactions at 100°C in closed vessels generate pressure. Use rated pressure vials (e.g., Biotage microwave vials or heavy-walled glass).
- Waste: Palladium and Copper waste must be segregated into heavy metal waste streams.

References

- Cacchi, S., et al. (2002). "Palladium-Catalyzed Reaction of Aryl Iodides and Arenesulfonates." *Organic Letters*.
- Ma, D., et al. (2005). "CuI/L-Proline Catalyzed Coupling of Aryl Halides with Sulfonates." *Journal of Organic Chemistry*.
- Manolikakes, G., et al. (2018). "Visible-Light Photoredox/Nickel Dual Catalysis for the Cross-Coupling of Sulfinic Acid Salts." *Organic Letters*.
- Mispelaere-Canivet, C., et al. (2005).[1] "Pd₂(dba)₃/Xantphos-catalyzed cross-coupling of thiols and aryl bromides." *Tetrahedron*. [1]
- Taniguchi, N. (2012).[2] "Copper-Catalyzed Oxidative Hydrosulfonylation of Alkynes Using Sodium Sulfonates." *Synlett*.

Need Custom Synthesis?

BenchChem offers custom synthesis for rare earth carbides and specific isotopic labeling.

Email: info@benchchem.com or [Request Quote Online](#).

Sources

- [1. Transition Metal Catalyzed Synthesis of Aryl Sulfides - PMC \[pmc.ncbi.nlm.nih.gov\]](#)
- [2. Sci-Hub. Copper-Catalyzed Oxidative Hydrosulfonylation of Alkynes Using Sodium Sulfinates in Air / Synlett, 2012 \[sci-hub.st\]](#)
- To cite this document: BenchChem. [Application Note: Catalytic Synthesis of 4-Fluorophenylethylsulfone Derivatives]. BenchChem, [2026]. [Online PDF]. Available at: [\[https://www.benchchem.com/product/b8654246/docs#application-note-catalytic-synthesis-of-4-fluorophenylethylsulfone-derivatives\]](https://www.benchchem.com/product/b8654246/docs#application-note-catalytic-synthesis-of-4-fluorophenylethylsulfone-derivatives)

Disclaimer & Data Validity:

The information provided in this document is for Research Use Only (RUO) and is strictly not intended for diagnostic or therapeutic procedures. While BenchChem strives to provide accurate protocols, we make no warranties, express or implied, regarding the fitness of this product for every specific experimental setup.

Technical Support: The protocols provided are for reference purposes. Unsure if this reagent suits your experiment?

Need Industrial/Bulk Grade? [Request Custom Synthesis Quote](#)

BenchChem

Our mission is to be the trusted global source of essential and advanced chemicals, empowering scientists and researchers to drive progress in science and industry.

Contact

Address: 3281 E Guasti Rd

Ontario, CA 91761, United States

Phone: (601) 213-4426

Email: info@benchchem.com

Contact our Ph.D. Support Team for a compatibility check