

# Controlling exotherms during large-scale nitrostyrene preparation

**Author:** BenchChem Technical Support Team. **Date:** April 2026

## Compound of Interest

Compound Name: *1-Benzyloxy-3-(2-nitrovinyl)benzene*

Cat. No.: *B8640055*

[Get Quote](#)

## Technical Support Center: Exotherm Management in Henry Reactions

Ticket ID: #NR-SC-882 | Topic: Large-Scale Nitrostyrene Preparation | Priority: Critical (Safety)

### Executive Summary: The Hazard Landscape

User Warning: You are scaling a nitroaldol condensation (Henry Reaction). On a bench scale (<50g), passive air cooling often masks the reaction's true thermal profile. On a process scale (>1kg), the surface-area-to-volume ratio drops drastically, turning your reactor into an adiabatic system.

The Core Threat: The reaction of benzaldehyde derivatives with nitromethane/nitroethane is highly exothermic (

).

- The Trigger: The initial addition of catalyst (alkylamine or ammonium acetate) overcomes the activation energy barrier.

- The Spike: Rapid formation of the nitronate intermediate releases immediate heat.
- The Runaway: If  
  
exceeds  
  
of nitromethane decomposition ( $\sim 300^{\circ}\text{C}$ , but lower in basic mixtures), you risk a deflagration.
- The Product Loss: Even without an explosion, temperatures  
  
(depending on the substrate) promote the irreversible polymerization of nitrostyrene into dark, insoluble tars.

## Engineering Controls & Setup (Visualized)

Directive: Do not rely on reflux condensers alone to remove heat.[1] Large-scale nitrostyrene synthesis requires active heat removal and dosing interlocks.

### Diagram 1: Process Safety Flow & Interlocks

This diagram illustrates the mandatory control loop for safe reagent addition.

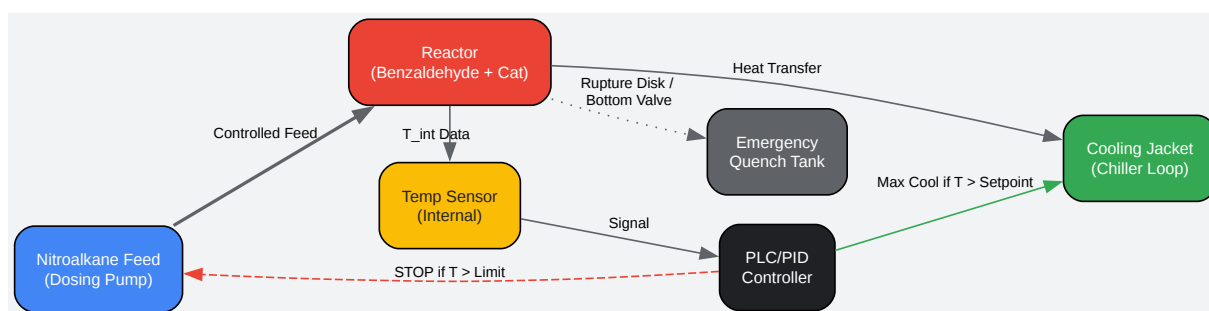

[Click to download full resolution via product page](#)

Caption: Figure 1. Active process control loop. The dosing pump is hard-wired to stop immediately if internal temperature exceeds the safety setpoint (e.g.,  $45^{\circ}\text{C}$ ).

## Chemical Control Strategies

Expert Insight: The choice of catalyst dictates your heat management strategy.

### Method A: Ammonium Acetate (The "Slow & Hot" Method)

- Mechanism: Weak acid/base equilibrium. Often run in acetic acid.
- Thermal Profile: Requires heat to start (endothermic induction), then sustains a moderate exotherm.
- Risk: If the reaction stalls and you add more catalyst before the exotherm kicks in, you create a "sleeping dragon." Once it starts, the accumulated reagents react all at once.
- Control: Maintain a steady reflux. If boiling stops, stop heating immediately. Do not add more reagents until reflux resumes.

### Method B: Alkylamines (The "Fast & Cold" Method)

- Mechanism: Direct deprotonation of nitroalkane.
- Thermal Profile: Instantaneous, sharp exotherm upon addition.
- Risk: Localized hot spots leading to tar formation.
- Control: Semi-batch addition. Dissolve the aldehyde and catalyst in solvent. Add the nitroalkane dropwise via the interlocked pump shown in Figure 1.

## Troubleshooting Guide (FAQ)

### Q1: The temperature is spiking despite the cooling jacket running at 100%.

Diagnosis: Your Dosing Rate > Heat Removal Capacity. Immediate Action:

- Kill the Feed: Stop the addition pump immediately.

- Increase Stirring: Viscosity often increases as the product precipitates. Ensure the impeller is moving the bulk fluid against the cooling walls.
- Do NOT Dump: Unless the pressure is rising, keep the material in the vessel. Dumping hot nitrostyrene into a cold quench tank can cause shock-crystallization and fouling.

## Q2: My product is turning into a dark red/black oil instead of yellow crystals.

Diagnosis: Thermal Polymerization. Causality: Nitrostyrenes are Michael acceptors. At high temperatures (>60°C for prolonged periods) or high pH, they polymerize. Solution:

- Lower your addition temperature (target 15–25°C).
- Reduce catalyst loading. Excess base catalyzes polymerization.
- Validation: Check the pH. If pH > 9, you are in the danger zone.

## Q3: I see a delay (induction period) after adding the catalyst.

Diagnosis: Moisture Interference or Low Temperature. Risk: Accumulation of unreacted reagents. Protocol:

- Stop Addition: Do not add the rest of the batch.
- Wait: Allow the exotherm to manifest from the initial portion.
- Seed: If using Method A, a small crystal of the product can induce precipitation and drive the equilibrium.

## Emergency Response Logic

Scenario: Thermal Runaway (Temperature rising >2°C/min with no feed).

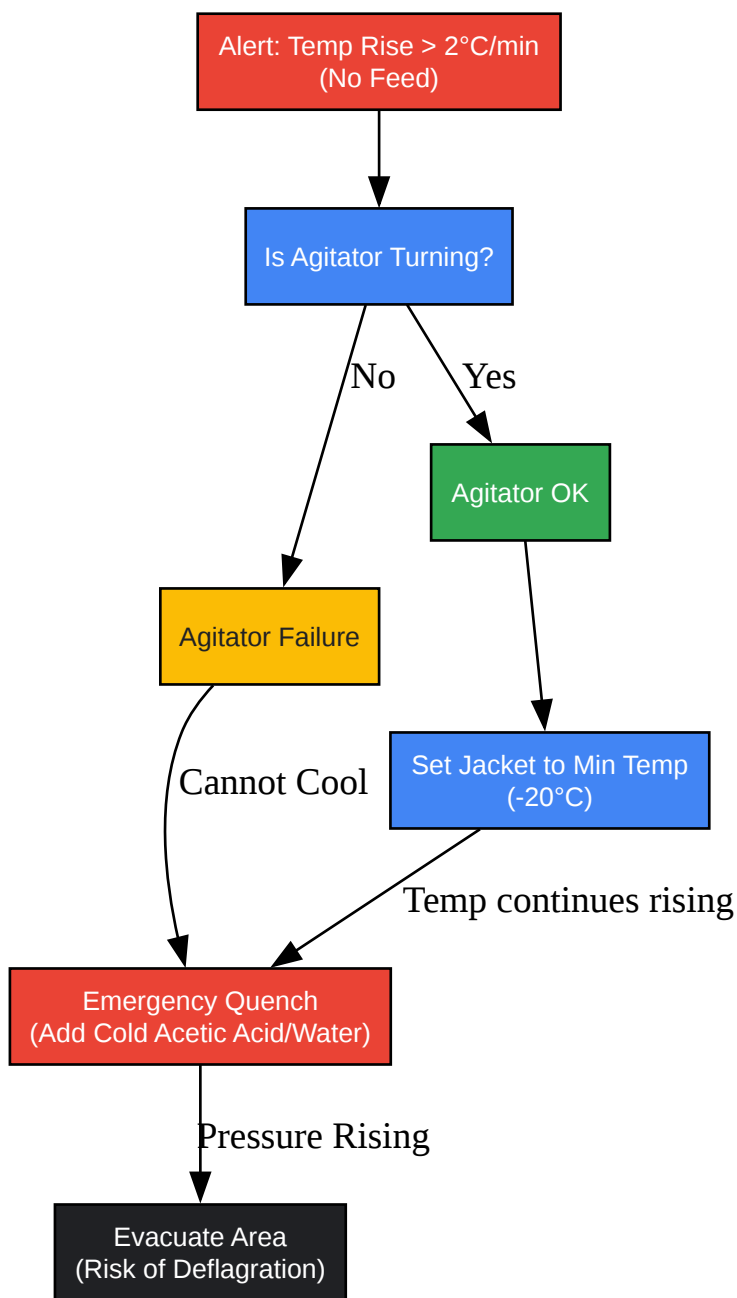

[Click to download full resolution via product page](#)

Caption: Figure 2. Decision tree for thermal runaway events. Note that agitation failure renders jacket cooling useless.

## Standardized Data Tables

### Table 1: Catalyst Impact on Exotherm Profile

Parameter	Ammonium Acetate (Method A)	n-Butylamine (Method B)	NaOH/KOH (Method C)
Reaction Rate	Slow (Hours)	Fast (Minutes)	Instant (Seconds)
Exotherm Type	Sustained, moderate heat	Sharp spikes per drop	Violent, immediate
Safety Risk	Induction period accumulation	Localized hot spots	Shock sensitive salts
Rec. Temp	Reflux (Acetic Acid)	0°C to 25°C	< 10°C
Scale-Up Suitability	High (Self-limiting by reflux)	Moderate (Requires dosing control)	Low (Too dangerous)

**Table 2: Critical Safety Thresholds**

Material	Hazard	Threshold Limit
Nitromethane	Explosive Decomposition	(Pure) (w/ Base)
Nitrostyrene	Polymerization (Tarring)	(Prolonged)
Sodium Nitronate	Shock Sensitivity	Do not let dry. Keep wet.

## References & Authority

- Organic Syntheses, Coll.[2] Vol. 1, p. 413 (1941). Nitrostyrene. [Link](#)
  - Foundational protocol establishing the base-catalyzed condensation method.
- Stoessel, F. (2008).[3] Thermal Safety of Chemical Processes: Risk Assessment and Process Design. Wiley-VCH.
  - Authoritative text on calculating cooling failure scenarios and TMR (Time to Maximum Rate).

- Bretherick's Handbook of Reactive Chemical Hazards. Nitromethane - Sodium Hydroxide Interaction.
  - Documents the shock sensitivity of dry nitronate salts formed in strong base conditions.
- Air & Waste Management Association. (2000). Reaction Runaway and Pressure Relief Design.
  - Engineering standards for sizing rupture disks for exothermic reactors.
- Anderson, N. G. (2012). Practical Process Research & Development. Academic Press.
  - Best practices for dosing controlled exothermic reactions in pharmaceutical scale-up.

### Need Custom Synthesis?

BenchChem offers custom synthesis for rare earth carbides and specific isotopic labeling.

Email: [info@benchchem.com](mailto:info@benchchem.com) or [Request Quote Online](#).

## Sources

- [1. Scale-Up Reaction Safety | Division of Research Safety | Illinois \[drs.illinois.edu\]](#)
- [2. Sciencemadness Discussion Board - knoevenagel condensation NaOH catalyst? - Powered by XMB 1.9.11 \[sciencemadness.org\]](#)
- [3. process-technology-online.com \[process-technology-online.com\]](#)
- To cite this document: BenchChem. [Controlling exotherms during large-scale nitrostyrene preparation]. BenchChem, [2026]. [Online PDF]. Available at: [\[https://www.benchchem.com/product/b8640055/docs#controlling-exotherms-during-large-scale-nitrostyrene-preparation\]](https://www.benchchem.com/product/b8640055/docs#controlling-exotherms-during-large-scale-nitrostyrene-preparation)

---

### Disclaimer & Data Validity:

The information provided in this document is for Research Use Only (RUO) and is strictly not intended for diagnostic or therapeutic procedures. While BenchChem strives to provide

accurate protocols, we make no warranties, express or implied, regarding the fitness of this product for every specific experimental setup.

**Technical Support:** The protocols provided are for reference purposes. Unsure if this reagent suits your experiment?

**Need Industrial/Bulk Grade?** [Request Custom Synthesis Quote](#)

## BenchChem

Our mission is to be the trusted global source of essential and advanced chemicals, empowering scientists and researchers to drive progress in science and industry.

### Contact

Address: 3281 E Guasti Rd

Ontario, CA 91761, United States

Phone: (601) 213-4426

Email: [info@benchchem.com](mailto:info@benchchem.com)

[Contact our Ph.D. Support Team for a compatibility check](#)