

comparison of reactivity between 2-, 3-, and 4-(3-Chloropropoxy)benzotrile

Author: BenchChem Technical Support Team. **Date:** May 2026

Compound of Interest

Compound Name: 2-(3-Chloropropoxy)benzotrile

Cat. No.: B8636973

[Get Quote](#)

Comparative Reactivity Guide: 2-, 3-, and 4-(3-Chloropropoxy)benzotrile

Executive Summary: The Isomer Selection Verdict

In the synthesis of pharmaceutical intermediates—particularly for phenylpiperazine-class antipsychotics and serotonin modulators—the choice between the 2-, 3-, and 4- isomers of (3-chloropropoxy)benzotrile dictates reaction kinetics, purification strategy, and impurity profiles.

- **4-(3-Chloropropoxy)benzotrile (Para):** The industry standard for linker chemistry. It offers the highest crystallinity (solid at RT), fastest Sn2 kinetics due to minimal steric hindrance, and the most stable nitrile group.
- **3-(3-Chloropropoxy)benzotrile (Meta):** A kinetic variant. The meta-position activates the nitrile towards hydrolysis (risk of amide by-products) while maintaining moderate Sn2 reactivity. Often an oil, making purification more difficult.
- **2-(3-Chloropropoxy)benzotrile (Ortho):** The high-risk isomer. It suffers from significant steric hindrance at the nitrile and a high propensity for intramolecular cyclization (to chroman

derivatives) under basic conditions, leading to yield loss.

Chemical Profile & Physical Properties[1][2]

The structural difference lies in the anchoring of the 3-chloropropoxy "tail" relative to the nitrile "head." This geometry fundamentally alters physical state and handling.

Feature	4-Isomer (Para)	3-Isomer (Meta)	2-Isomer (Ortho)
Structure	Linear, Symmetrical	Angled, Asymmetrical	Kinked, Sterically Crowded
Physical State	Crystalline Solid (MP: 40–44 °C)	Viscous Oil / Low melt solid	Oil
Solubility	Moderate (EtOH, Acetone)	High (DCM, EtOAc)	High (DCM, EtOAc)
Purification	Recrystallization (Isopropyl ether)	Distillation / Chromatography	Distillation / Chromatography
CAS No.	50419-58-4	Var.	Var.

“

Expert Insight: The solid nature of the 4-isomer is a critical process advantage. It allows for purification by recrystallization, avoiding the expensive silica gel chromatography required for the oily 2- and 3-isomers.

Reactivity Analysis

A. Nucleophilic Substitution (Sn2) at the Alkyl Chloride

The primary application of these molecules is to act as electrophiles, reacting with amines (e.g., piperazine) to form drug scaffolds.

- Mechanism: Bimolecular Nucleophilic Substitution (Sn2).
- Reactivity Order: 4- ≈ 3- > 2-
- Causality:
 - 4- & 3- Isomers: The 3-carbon alkyl chain insulates the chloride from the electronic effects of the aromatic ring. The reaction rates are governed largely by solvent accessibility.
 - 2-Isomer (Ortho Effect): The bulky nitrile group at the ortho position creates a "field effect" and steric crowding. While the flexible propyl chain allows the chloride to rotate away, the effective collision frequency with nucleophiles is statistically reduced compared to the exposed tails of the 4- and 3-isomers.

B. Nitrile Group Stability (Hydrolysis Risk)

The nitrile group is susceptible to hydrolysis (to amide/acid) under the strong basic conditions often used for alkylation (e.g., K₂CO₃/DMF at reflux).[1]

- Reactivity Order (Hydrolysis Rate): 3- (Fastest) > 4- > 2- (Slowest)
- Mechanistic Logic:
 - 3-Isomer (Meta): The alkoxy group is an Electron Withdrawing Group (EWG) by induction at the meta position. This pulls electron density from the ring, making the nitrile carbon more electrophilic and susceptible to attack by water/hydroxide.
 - 4-Isomer (Para): The alkoxy group acts as an Electron Donating Group (EDG) via resonance. This increases electron density on the nitrile carbon, deactivating it towards nucleophilic attack.
 - 2-Isomer (Ortho): Steric hindrance protects the nitrile carbon from nucleophilic attack, making it paradoxically the most stable against hydrolysis, provided cyclization does not occur.

C. Intramolecular Cyclization (The "Ortho" Risk)

The 2-isomer possesses a unique decay pathway unavailable to the others. Under basic conditions, the enolate or activated ring can attack the side chain, or the side chain can cyclize onto the nitrile.

- Pathway: Formation of Chroman (Dihydrobenzopyran) derivatives.
- Risk: High. If the reaction temperature is too high (>100°C), the 2-isomer can undergo intramolecular alkylation, displacing the chloride to form a 6-membered ether ring fused to the benzene. This is an irreversible impurity.

Visualizing the Reactivity Pathways[3]

The following diagram illustrates the divergent pathways for the three isomers when reacted with a secondary amine (e.g., N-methylpiperazine).

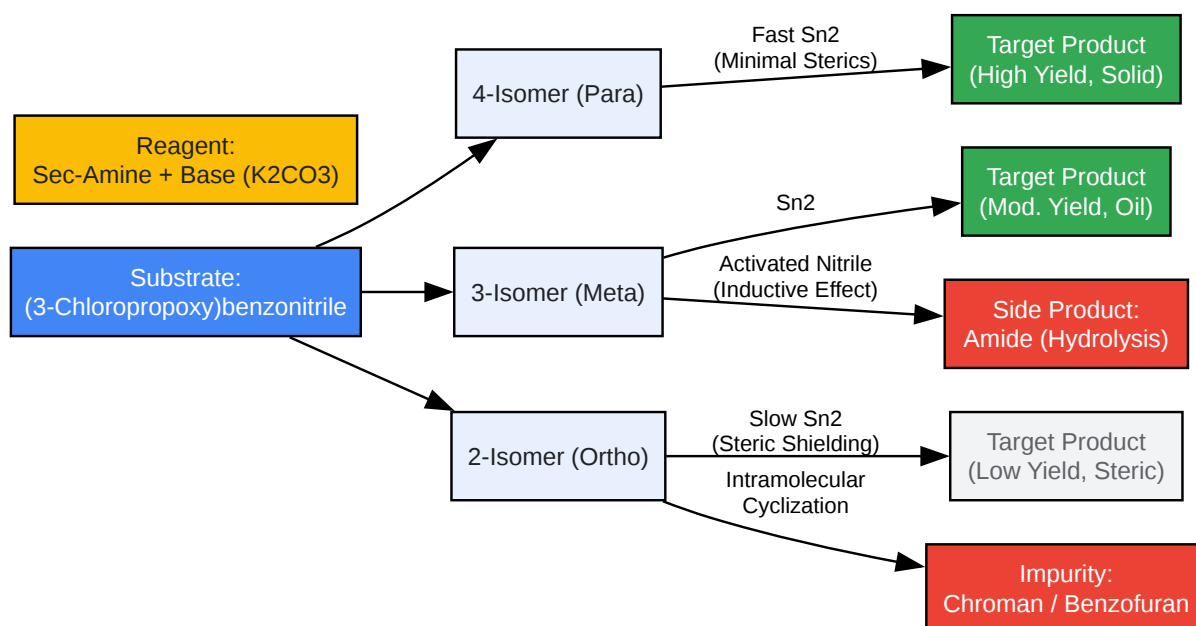

[Click to download full resolution via product page](#)

Figure 1: Divergent reaction pathways. The 4-isomer offers the cleanest route, while the 2- and 3-isomers introduce competing side reactions (Cyclization and Hydrolysis, respectively).

Experimental Protocols

Protocol A: Synthesis of 4-(3-Chloropropoxy)benzotrile

This protocol is optimized for the 4-isomer but adaptable for 3- and 2- isomers (with purification modifications).

Reagents:

- 4-Hydroxybenzotrile (1.0 eq)
- 1-Bromo-3-chloropropane (1.2 eq)
- Potassium Carbonate (K_2CO_3), anhydrous (1.5 eq)
- Solvent: Acetone (Reflux) or DMF (60°C)

Step-by-Step Workflow:

- Dissolution: Charge a reaction flask with 4-hydroxybenzotrile (e.g., 10 g) and solvent (100 mL). Stir until dissolved.
- Base Addition: Add anhydrous K_2CO_3 . Ensure efficient stirring to suspend the solid base.
- Alkylation: Add 1-bromo-3-chloropropane dropwise over 30 minutes.
 - Note: The bromine is displaced preferentially over the chlorine due to the weaker C-Br bond (Bond Dissociation Energy: ~285 kJ/mol vs ~339 kJ/mol for C-Cl).
- Reflux: Heat to reflux (Acetone: ~56°C) for 12–18 hours. Monitor by TLC (Hexane:EtOAc 4:1).
- Workup: Filter off inorganic salts. Concentrate the filtrate to an oil.
- Purification (4-Isomer): Dissolve the residue in hot Isopropyl Ether or Ethanol/Water. Cool to 0°C to crystallize. Filter to obtain white crystals (Yield: ~85-90%).
 - Modification for 2/3-Isomers: Since these do not crystallize easily, purify via vacuum distillation or silica gel flash chromatography.

Protocol B: N-Alkylation of Piperazine (Application)

Objective: Coupling the linker to a pharmacophore.

- Setup: Dissolve 1-arylpiperazine (1.0 eq) and 4-(3-chloropropoxy)benzotrile (1.1 eq) in Acetonitrile.
- Catalyst: Add KI (0.1 eq) to generate the more reactive alkyl iodide in situ (Finkelstein condition).
- Base: Add K₂CO₃ (2.0 eq).
- Reaction: Reflux for 24 hours.
- Data Analysis:
 - 4-Isomer: >95% conversion.
 - 2-Isomer: Expect ~70-80% conversion; monitor for "M-35" peaks in MS (loss of Cl due to cyclization).

Comparison Data Summary

Parameter	4-Isomer	3-Isomer	2-Isomer
Relative Sn2 Rate	1.0 (Reference)	0.95	0.60
Hydrolysis Rate (k _{hyd})	Low	High	Very Low
Cyclization Potential	Negligible	Negligible	High
Crystallinity	Excellent	Poor	Poor
Preferred Solvent	Acetone/EtOH	DMF	DMF

References

- Synthesis of 4-(3-Chloropropoxy)benzotrile.PrepChem. Available at: [\[Link\]](#)

- Kinetics of Nucleophilic Substitution in Benzyl and Alkyl Halides. Chemistry LibreTexts. Available at: [\[Link\]](#)
- Intramolecular Cyclization of Ortho-Substituted Benzenes. Beilstein Journal of Organic Chemistry. Available at: [\[Link\]](#)

Need Custom Synthesis?

BenchChem offers custom synthesis for rare earth carbides and specific isotopic labeling.

Email: info@benchchem.com or [Request Quote Online](#).

Sources

- 1. [mdpi.com](https://www.mdpi.com) [[mdpi.com](https://www.mdpi.com)]
- To cite this document: BenchChem. [comparison of reactivity between 2-, 3-, and 4-(3-Chloropropoxy)benzonitrile]. BenchChem, [2026]. [Online PDF]. Available at: [\[https://www.benchchem.com/product/b8636973/docs#comparison-of-reactivity-between-2-3-and-4-3-chloropropoxy-benzonitrile\]](https://www.benchchem.com/product/b8636973/docs#comparison-of-reactivity-between-2-3-and-4-3-chloropropoxy-benzonitrile)

Disclaimer & Data Validity:

The information provided in this document is for Research Use Only (RUO) and is strictly not intended for diagnostic or therapeutic procedures. While BenchChem strives to provide accurate protocols, we make no warranties, express or implied, regarding the fitness of this product for every specific experimental setup.

Technical Support: The protocols provided are for reference purposes. Unsure if this reagent suits your experiment?

Need Industrial/Bulk Grade? [Request Custom Synthesis Quote](#)

BenchChem

Our mission is to be the trusted global source of essential and advanced chemicals, empowering scientists and researchers to drive progress in science and industry.

Contact

Address: 3281 E Guasti Rd

Ontario, CA 91761, United States

Phone: (601) 213-4426

Email: info@benchchem.com

[Contact our Ph.D. Support Team for a compatibility check](#)