

Using 2-Chloro-3-cyclopropoxyppyridine as a pharmaceutical intermediate

Author: BenchChem Technical Support Team. **Date:** April 2026

Compound of Interest

Compound Name: 2-Chloro-3-cyclopropoxyppyridine

Cat. No.: B8633004

[Get Quote](#)

Application Note: **2-Chloro-3-cyclopropoxyppyridine** as a Strategic Pharmaceutical Intermediate

Executive Summary

2-Chloro-3-cyclopropoxyppyridine (CAS 1243368-75-3) is a high-value heterocyclic building block used extensively in the synthesis of small-molecule therapeutics. Its structural uniqueness lies in the 3-cyclopropoxy group, a motif that serves as a metabolically stable, lipophilic bioisostere for methoxy or ethoxy groups. This intermediate is particularly relevant in the development of kinase inhibitors, PDE4 inhibitors, and GPCR ligands, where the pyridine ring acts as a hinge binder or core scaffold and the cyclopropyl ether modulates physicochemical properties (logP, pKa) and metabolic clearance.

This guide details the strategic utility of this compound and provides validated protocols for its functionalization via Palladium-catalyzed cross-coupling and Nucleophilic Aromatic Substitution ().

Chemical Profile & Safety

Property	Specification
Chemical Name	2-Chloro-3-cyclopropoxy pyridine
CAS Number	1243368-75-3
Molecular Formula	
Molecular Weight	169.61 g/mol
Appearance	Colorless to pale yellow liquid or low-melting solid
Boiling Point	~245°C (Predicted)
Solubility	Soluble in DCM, EtOAc, THF, MeOH; Insoluble in water
Storage	2-8°C, Inert atmosphere (Argon/Nitrogen)
Hazards	Irritant (Skin/Eye/Respiratory).[1] Handle in a fume hood.

Strategic Utility in Drug Design

The "Cyclopropoxy Effect"

In medicinal chemistry, replacing a standard alkoxy group (e.g.,

) with a cyclopropoxy group (

) often yields significant pharmacological advantages:

- **Metabolic Stability:** The cyclopropyl ring inhibits -hydroxylation (a common metabolic soft spot in ethers), thereby extending the half-life () of the API.
- **Conformational Restriction:** The steric bulk of the cyclopropyl group can lock the ether linkage into a preferred conformation, potentially improving binding affinity to target proteins (e.g., kinase ATP pockets).

- Lipophilicity Modulation: It increases lipophilicity () compared to a methoxy group without the flexibility penalty of a propyl chain.

Reactivity Profile

The 2-chloro substituent is activated by the adjacent pyridine nitrogen, making it a prime candidate for:

- Suzuki-Miyaura Coupling: Formation of Biaryl/Heterobiaryl systems.[2]
- Buchwald-Hartwig Amination: Introduction of amine side chains (common in kinase inhibitors).
- Displacement: Reaction with strong nucleophiles (thiols, alkoxides) under elevated temperatures.

Experimental Protocols

Protocol A: Suzuki-Miyaura Cross-Coupling

Objective: To synthesize 2-aryl-3-cyclopropoxypyridine derivatives.

Mechanism: The electron-rich cyclopropoxy group at C3 slightly deactivates the C2-Cl bond compared to a bare 2-chloropyridine. Therefore, highly active phosphine ligands (e.g., XPhos, SPhos) are recommended over standard

Materials:

- Substrate: **2-Chloro-3-cyclopropoxypyridine** (1.0 equiv)
- Boronic Acid: Arylboronic acid (1.2 equiv)
- Catalyst:
(2 mol%) or
- Ligand: XPhos or SPhos (4-8 mol%)

- Base:

(2.0 equiv, 2M aqueous solution)

- Solvent: 1,4-Dioxane or Toluene/Water (10:1)

Procedure:

- Setup: Charge a reaction vial with the substrate, arylboronic acid, Pd catalyst, and ligand.
- Degassing: Seal the vial and purge with Argon for 5 minutes.
- Solvent Addition: Add degassed solvent and aqueous base via syringe.
- Reaction: Heat the mixture to 90-100°C for 4–12 hours. Monitor conversion by LC-MS (Target mass:).
- Workup: Cool to RT. Dilute with EtOAc, wash with water and brine. Dry over .^[3]
- Purification: Flash column chromatography (Hexane/EtOAc gradient).

Troubleshooting:

- Low Conversion? Switch to a precatalyst like XPhos Pd G2 to ensure rapid initiation.
- Dehalogenation? Ensure the solvent is rigorously degassed to prevent hydrodehalogenation.

Protocol B: Buchwald-Hartwig Amination

Objective: To introduce an amino group at the C2 position (e.g., for aminopyridine kinase inhibitors).

Materials:

- Substrate: **2-Chloro-3-cyclopropoxypyridine** (1.0 equiv)

- Amine: Primary or Secondary amine (1.2 equiv)
- Catalyst:

(5 mol%)
- Ligand: BINAP or BrettPhos (5-10 mol%)
- Base:

or NaOtBu (1.5 equiv)
- Solvent: Toluene or 1,4-Dioxane (Anhydrous)

Procedure:

- Preparation: In a glovebox or under Argon, combine substrate, amine, base, catalyst, and ligand in a pressure tube.
- Heating: Add anhydrous solvent. Seal and heat to 100-110°C for 12–18 hours.
- Monitoring: Check for disappearance of the starting chloride via TLC or HPLC.
- Workup: Filter through a Celite pad to remove insoluble salts. Concentrate the filtrate.
- Purification: Silica gel chromatography. Note: Pyridyl amines can be polar; add 1%

to the eluent.

Pathway Visualization

The following diagram illustrates the divergent synthesis pathways utilizing **2-Chloro-3-cyclopropoxy pyridine** as a core scaffold.

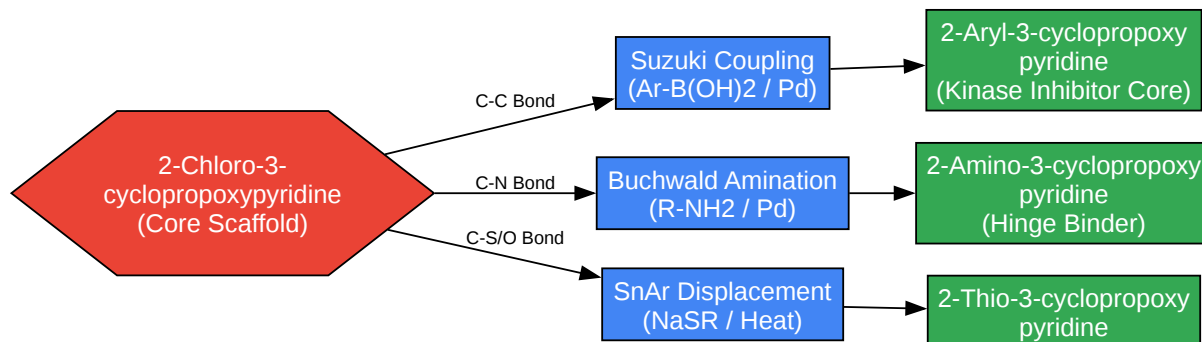

[Click to download full resolution via product page](#)

Caption: Divergent synthesis pathways transforming the 2-chloro core into functionalized bioactive scaffolds.

References

- Compound Availability & Properties
- Suzuki Coupling on Chloropyridines
 - Miyaura, N., & Suzuki, A. (1995). Palladium-Catalyzed Cross-Coupling Reactions of Organoboron Compounds.[2] *Chemical Reviews*, 95(7), 2457–2483. [[Link](#)]
- Cyclopropyl Ethers in Medicinal Chemistry
 - Wuitschik, G., et al. (2008). Oxetanes as Promising Modules in Drug Discovery. (Discusses comparative stability of small cyclic ethers). *Angewandte Chemie*. [[Link](#)]
- Buchwald-Hartwig Conditions for Pyridines
 - Surry, D. S., & Buchwald, S. L. (2008). Biaryl Phosphane Ligands in Palladium-Catalyzed Amination. *Angewandte Chemie International Edition*, 47(34), 6338–6361. [[Link](#)]

Need Custom Synthesis?

BenchChem offers custom synthesis for rare earth carbides and specific isotopic labeling.

Email: info@benchchem.com or [Request Quote Online](#).

Sources

- [1. 2-Chloro-3-cyanopyridine | Drug Information, Uses, Side Effects, Pharma intermediate Chemistry | PharmaCompass.com \[pharmacompass.com\]](#)
- [2. pdf.benchchem.com \[pdf.benchchem.com\]](#)
- [3. patentimages.storage.googleapis.com \[patentimages.storage.googleapis.com\]](#)
- To cite this document: BenchChem. [Using 2-Chloro-3-cyclopropoxy pyridine as a pharmaceutical intermediate]. BenchChem, [2026]. [Online PDF]. Available at: [<https://www.benchchem.com/product/b8633004/docs#using-2-chloro-3-cyclopropoxy pyridine-as-a-pharmaceutical-intermediate>]

Disclaimer & Data Validity:

The information provided in this document is for Research Use Only (RUO) and is strictly not intended for diagnostic or therapeutic procedures. While BenchChem strives to provide accurate protocols, we make no warranties, express or implied, regarding the fitness of this product for every specific experimental setup.

Technical Support: The protocols provided are for reference purposes. Unsure if this reagent suits your experiment?

Need Industrial/Bulk Grade? [Request Custom Synthesis Quote](#)

BenchChem

Our mission is to be the trusted global source of essential and advanced chemicals, empowering scientists and researchers to drive progress in science and industry.

Contact

Address: 3281 E Guasti Rd
Ontario, CA 91761, United States
Phone: (601) 213-4426
Email: info@benchchem.com

[Contact our Ph.D. Support Team for a compatibility check](#)