

Synthesis of Poly(3-methoxythiophene): A Detailed Guide for Organic Electronics Applications

Author: BenchChem Technical Support Team. **Date:** April 2026

Compound of Interest

Compound Name: Thiophene, 3-methoxy-2-(methylthio)-

Cat. No.: B8618683

[Get Quote](#)

Introduction

Poly(3-methoxythiophene) (P3MT) has emerged as a significant conductive polymer in the field of organic electronics, prized for its unique combination of electronic properties, processability, and environmental stability. The presence of the electron-donating methoxy group at the 3-position of the thiophene ring lowers the oxidation potential of the monomer, facilitating polymerization and tuning the optoelectronic characteristics of the resulting polymer.^[1] This makes P3MT a compelling material for a range of applications, including electrochromic devices, organic solar cells, and sensors.^{[1][2]}

This comprehensive guide provides detailed protocols and in-depth scientific rationale for the synthesis of P3MT, targeting researchers and professionals in materials science and drug development. We will explore the two primary methods for P3MT synthesis: oxidative chemical polymerization and electrochemical polymerization. Each section will elucidate the underlying mechanisms, provide step-by-step experimental procedures, and discuss the critical parameters that influence the final properties of the polymer.

PART 1: Oxidative Chemical Polymerization

Oxidative chemical polymerization is a widely employed method for the synthesis of polythiophenes due to its scalability and relative simplicity. The process involves the use of a chemical oxidizing agent, most commonly iron(III) chloride (FeCl_3), to initiate the polymerization of the 3-methoxythiophene monomer.

Mechanistic Insights

The polymerization proceeds via an oxidative coupling mechanism. The oxidizing agent, FeCl_3 , abstracts an electron from the electron-rich thiophene ring of the 3-methoxythiophene monomer, generating a radical cation. This radical cation can then couple with another radical cation or a neutral monomer, leading to the formation of a dimer. Subsequent oxidation and coupling steps propagate the polymer chain. The choice of solvent and the monomer-to-oxidant ratio are critical parameters that significantly impact the molecular weight, regioregularity, and ultimately the electronic properties of the synthesized P3MT.^{[3][4]}

Diagram: Oxidative Chemical Polymerization Workflow

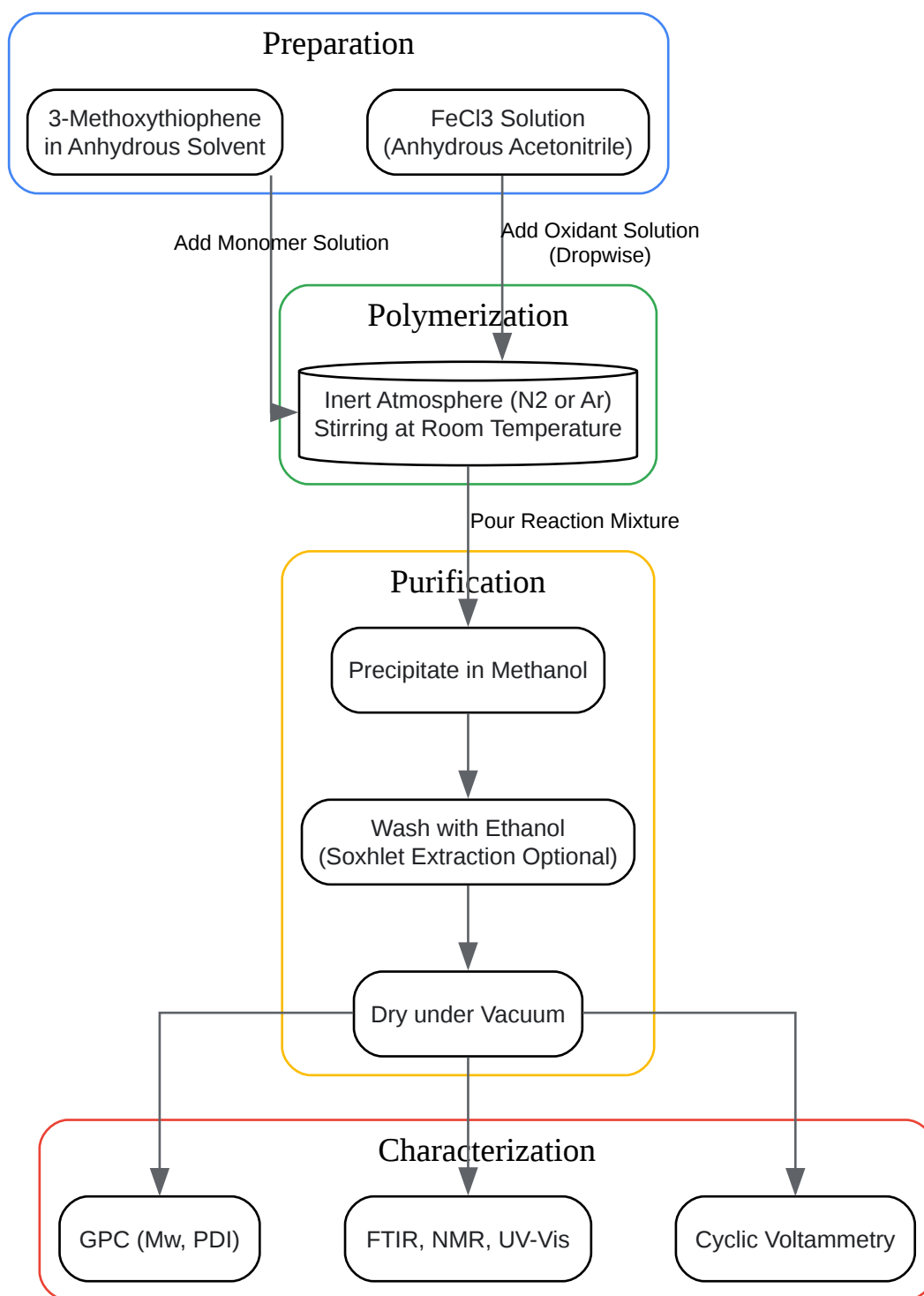

[Click to download full resolution via product page](#)

Caption: Workflow for Oxidative Chemical Synthesis of P3MT.

Protocol: Oxidative Chemical Synthesis of P3MT using FeCl₃

This protocol is a robust starting point for the synthesis of P3MT. Researchers are encouraged to systematically vary parameters such as reaction time and monomer-to-oxidant ratio to optimize for desired polymer characteristics.

Materials:

- 3-Methoxythiophene (MOT) monomer (98% or higher purity)
- Anhydrous iron(III) chloride (FeCl₃)
- Anhydrous acetonitrile
- Anhydrous chloroform or dichloromethane[4]
- Methanol
- Ethanol

Procedure:

- **Monomer Solution Preparation:** In a dry, two-neck round-bottom flask under an inert atmosphere (e.g., nitrogen or argon), dissolve a specific amount of 3-methoxythiophene monomer in anhydrous chloroform or dichloromethane. A typical concentration is 0.1 M.[5]
- **Oxidant Solution Preparation:** In a separate dry flask, prepare a solution of anhydrous FeCl₃ in anhydrous acetonitrile. A common concentration is 0.2 M.[5] The use of acetonitrile enhances the solubility and reactivity of the FeCl₃.
- **Polymerization Reaction:** While vigorously stirring the monomer solution at room temperature, add the FeCl₃ solution dropwise over a period of 30 minutes.[6] A rapid color change from colorless to a dark purple or dark blue solution indicates the initiation of polymerization.[5]

- **Reaction Progression:** Allow the reaction to stir at room temperature for a designated period, typically 2 to 24 hours. The reaction time is a critical parameter influencing the molecular weight of the resulting polymer.[6]
- **Polymer Precipitation and Collection:** After the reaction is complete, pour the dark polymer solution into a beaker containing a large excess of methanol. This will cause the P3MT to precipitate out of the solution. Collect the precipitate by suction filtration.
- **Purification:** The crude polymer will contain residual oxidant and oligomers. To purify, wash the precipitate extensively with ethanol to remove these impurities.[5] For higher purity, Soxhlet extraction with methanol followed by hexane can be employed. This multi-step washing is crucial for obtaining a polymer with reliable electronic properties.[7]
- **Drying:** Dry the purified P3MT powder in a vacuum oven at a moderate temperature (e.g., 40-50 °C) until a constant weight is achieved.

Key Experimental Parameters and Their Impact

Parameter	Typical Range	Rationale and Impact on Polymer Properties
Monomer:Oxidant Molar Ratio	1:2 to 1:4	A higher oxidant ratio can lead to higher yields and molecular weights, but an excessive amount may cause over-oxidation and defects in the polymer chain, reducing conductivity.[8][9]
Solvent	Chloroform, Dichloromethane	The choice of solvent affects the solubility of the growing polymer chains and the oxidant. Chloroform generally yields higher molecular weight P3MT compared to dichloromethane.[4]
Reaction Time	2 - 48 hours	Longer reaction times generally lead to higher molecular weights, but there is a point of diminishing returns. Optimization is necessary for specific applications.[9]
Temperature	Room Temperature	While some polymerizations are conducted at elevated temperatures, room temperature is often sufficient for P3MT synthesis and helps to minimize side reactions.

PART 2: Electrochemical Polymerization

Electrochemical polymerization offers a high degree of control over the polymerization process, allowing for the direct deposition of a uniform P3MT film onto a conductive substrate. This

method is particularly advantageous for the fabrication of electronic devices where thin, well-adhered films are required.

Mechanistic Insights

In electrochemical polymerization, a potential is applied to an electrode immersed in a solution containing the 3-methoxythiophene monomer and a supporting electrolyte. The monomer is oxidized at the electrode surface to form radical cations. These reactive species then couple and propagate the polymer chain, which deposits onto the electrode surface as a film. The properties of the resulting film, such as thickness, morphology, and conductivity, can be precisely controlled by manipulating the electrochemical parameters, including the applied potential, current density, and the composition of the electrolyte solution.[10][11]

Diagram: Electrochemical Polymerization Setup

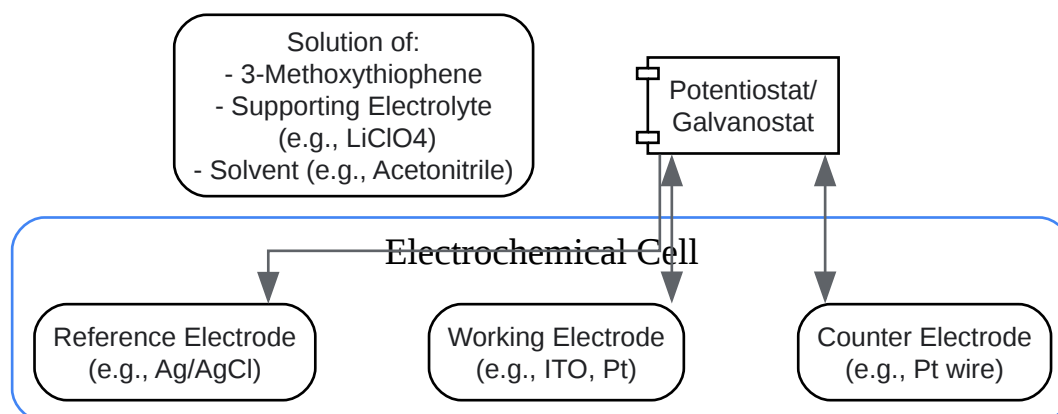

[Click to download full resolution via product page](#)

Caption: A typical three-electrode setup for the electrochemical polymerization of P3MT.

Protocol: Electrochemical Synthesis of P3MT Films

This protocol describes a general method for the potentiodynamic or potentiostatic deposition of P3MT films.

Materials:

- 3-Methoxythiophene (MOT) monomer

- Lithium perchlorate (LiClO_4) or other suitable supporting electrolyte
- Anhydrous acetonitrile
- Working electrode (e.g., indium tin oxide (ITO) coated glass, platinum disk)[12][13]
- Counter electrode (e.g., platinum wire or foil)
- Reference electrode (e.g., Ag/AgCl or saturated calomel electrode (SCE))[13]

Procedure:

- Electrolyte Preparation: Prepare a solution of the 3-methoxythiophene monomer (e.g., 0.1 M) and the supporting electrolyte (e.g., 0.1 M LiClO_4) in anhydrous acetonitrile.[11]
- Electrochemical Cell Assembly: Assemble a three-electrode electrochemical cell with the working, counter, and reference electrodes immersed in the electrolyte solution. Ensure the working electrode surface is clean and polished.
- Electropolymerization:
 - Potentiodynamic Method (Cyclic Voltammetry): Cycle the potential of the working electrode between a lower limit (e.g., -0.5 V) and an upper limit (e.g., +1.3 V vs. SCE) at a specific scan rate (e.g., 10-50 mV/s).[1][11] An increase in the peak currents with each cycle indicates the deposition and growth of a conductive polymer film.
 - Potentiostatic Method: Apply a constant potential at which the monomer oxidizes (e.g., 1.1 V vs. SCE) for a set duration.[1] The film thickness can be controlled by the polymerization time and the charge passed.
- Film Rinsing and Drying: After polymerization, carefully remove the working electrode from the cell and rinse it with fresh acetonitrile to remove any unreacted monomer and electrolyte. Dry the P3MT film under a stream of inert gas or in a vacuum oven.

Key Electrochemical Parameters and Their Impact

Parameter	Typical Range	Rationale and Impact on Film Properties
Applied Potential/Current	1.1 - 1.5 V vs. SCE	Higher potentials can increase the polymerization rate but may also lead to over-oxidation and a less ordered film structure.[1]
Scan Rate (Potentiodynamic)	10 - 100 mV/s	Slower scan rates can result in more uniform and crystalline polymer films.[11]
Supporting Electrolyte	LiClO ₄ , Bu ₄ NClO ₄	The size and nature of the electrolyte anion affect the morphology, conductivity, and electrochemical stability of the P3MT film.
Monomer Concentration	0.05 - 0.2 M	Higher concentrations generally lead to faster film growth.

PART 3: Characterization of Poly(3-methoxythiophene)

Thorough characterization is essential to correlate the synthesis parameters with the final properties of the P3MT and to ensure its suitability for a given application.

Structural and Molecular Weight Analysis

- Fourier-Transform Infrared (FTIR) Spectroscopy: FTIR is used to confirm the successful polymerization by identifying the characteristic vibrational modes of the polythiophene backbone and the methoxy side chains. The disappearance of the C-H out-of-plane vibration of the monomer at the 2- and 5-positions of the thiophene ring is a key indicator of polymerization.[6]

- Nuclear Magnetic Resonance (NMR) Spectroscopy: ^1H and ^{13}C NMR spectroscopy provide detailed information about the polymer's structure and regioregularity. The chemical shifts of the aromatic protons on the thiophene ring can be used to quantify the degree of head-to-tail linkages, which significantly influences the polymer's electronic properties.[14][15]
- Gel Permeation Chromatography (GPC): GPC is the standard method for determining the number-average molecular weight (M_n), weight-average molecular weight (M_w), and the polydispersity index (PDI) of the soluble polymer fraction. These parameters are crucial for understanding the processability and mechanical properties of the material.[13][16]

Optical, Electrochemical, and Morphological Characterization

- UV-Visible (UV-Vis) Spectroscopy: The UV-Vis absorption spectrum reveals information about the π - π^* transition of the conjugated polymer backbone. The position of the absorption maximum (λ_{max}) is indicative of the effective conjugation length; a red-shift in λ_{max} generally corresponds to a longer conjugation length and a more ordered polymer structure. [6][17]
- Cyclic Voltammetry (CV): CV is used to study the redox behavior of the P3MT film. The oxidation and reduction potentials provide insights into the polymer's electronic energy levels (HOMO and LUMO) and its electrochemical stability.[1]
- Scanning Electron Microscopy (SEM): SEM is employed to visualize the surface morphology of the P3MT films, providing information on their uniformity, porosity, and grain structure.

Expected Characterization Data for P3MT

Characterization Technique	Expected Results and Interpretation
FTIR	Presence of characteristic peaks for the polythiophene backbone and C-O-C stretching of the methoxy group.
¹ H NMR	Broad signals in the aromatic region (around 7.0 ppm) corresponding to the thiophene ring protons.[14][18]
GPC	Mn typically in the range of 2,000-20,000 g/mol with a PDI between 1.2 and 2.5 for chemically synthesized P3MT.[6][16]
UV-Vis (in solution)	Absorption maximum (λ_{max}) in the range of 450-500 nm.[6]
UV-Vis (thin film)	Red-shifted λ_{max} compared to the solution spectrum, often with a vibronic shoulder, indicating intermolecular interactions in the solid state.[19]
Cyclic Voltammetry	Reversible oxidation and reduction peaks, with the oxidation onset potential providing an estimate of the HOMO energy level.

Conclusion

The synthesis of poly(3-methoxythiophene) is a versatile process that can be tailored to achieve a wide range of material properties for applications in organic electronics. By carefully controlling the synthesis parameters in either oxidative chemical or electrochemical polymerization, researchers can fine-tune the molecular weight, regioregularity, and morphology of P3MT. The detailed protocols and mechanistic insights provided in this guide serve as a comprehensive resource for the successful synthesis and characterization of this promising conducting polymer. As the demand for advanced organic electronic materials continues to grow, a thorough understanding of the synthesis-property relationships of polymers like P3MT will be paramount for future innovations.

References

- Dieng, M. M., et al. (1999). Electrosynthesis and characterization of poly(3-methoxythiophene)–polybithiophene composite films prepared in micellar media on Pt and Fe substrates. *Physical Chemistry Chemical Physics*, 1(8), 1731-1734. [[Link](#)]
- Hoshino, K., et al. (2024). A New Method for Preparing Metallic Luster of 3-Methoxythiophene Polymers. *Journal of The Electrochemical Society of Japan*, 92(1), 1-5. [[Link](#)]
- de Souza, J. C., et al. (2008). Electrochemical polymerization and characterization of new copolymers of 3-substituted thiophenes. *Journal of the Brazilian Chemical Society*, 19(5), 978-985. [[Link](#)]
- Wang, Y., et al. (2015). Synthesis and thermopower of poly(3-methoxythiophene-2,5-diyl-co-3,4-ethylenedioxythiophene-2,5-diyl)/tosylate. *RSC Advances*, 5(82), 67023-67028. [[Link](#)]
- Hoshino, K., et al. (2026). Preparation, characterization, and magnetic properties of poly(3-methoxythiophene)-Fe₃O₄ conducting nanocomposite. *RSC Advances*, 16(1), 1-10. [[Link](#)]
- Alves, R. B., et al. (2013). Synthesis and characterization of new 3-substituted thiophene copolymers. *Journal of the Brazilian Chemical Society*, 24(2), 248-255. [[Link](#)]
- Lin, Y.-C., et al. (2024). 3,6-Dimethoxythieno[3,2-b]thiophene-Based Bifunctional Electrodes for High-Performance Electrochromic Supercapacitors Prepared by One-Step Electrodeposition. *Polymers*, 16(16), 2187. [[Link](#)]
- Kumar, A., & Reynolds, J. R. (1998). Electrochemical Synthesis and Characterization Studies of Poly[3,3'-dialkylsulfanyl-2,2'-bithiophene] Films. *Macromolecules*, 31(15), 4847-4853. [[Link](#)]
- Shi, C., et al. (2006). Regioregular Copolymers of 3-Alkoxythiophene and Their Photovoltaic Application. *Journal of the American Chemical Society*, 128(26), 8490-8500. [[Link](#)]
- Wei, Y., et al. (1993). Electrochemical Polymerization of Thiophenes in the Presence of Bithiophene or Terthiophene: Kinetics and Mechanism of the Polym. DTIC. [[Link](#)]

- Sheina, E. E., et al. (2004). Efficient formation, isolation and characterization of poly(3-alkylthiophene) nanofibres: probing order as a function of side-chain length and regioregularity. *Journal of Materials Chemistry*, 14(18), 2746-2753. [[Link](#)]
- Sharma, S. K., et al. (2018). Recent developments in the synthesis of regioregular thiophene-based conjugated polymers for electronic and optoelectronic applications using nickel and palladium-based catalytic systems. *RSC Advances*, 8(26), 14354-14382. [[Link](#)]
- Li, G., et al. (2012). Solid-State Synthesis of Poly(3',4'-dimethoxy-2,2':5',2"-terthiophene). *Molecules*, 17(8), 8823-8837. [[Link](#)]
- Niemi, V. M., et al. (1992). Polymerization of 3-alkylthiophenes with FeCl₃. *Polymer*, 33(7), 1559-1562. [[Link](#)]
- Zotti, G., et al. (1996). In Situ Conductivity of a Polythiophene from a Branched Alkoxy-Substituted Tetrathiophene. Enhancement of Conductivity by Conjugated Cross-Linking of Polymer Chains. *Chemistry of Materials*, 8(11), 2589-2595. [[Link](#)]
- Hasoon, S. (2013). The Electro polymerization of (3-methylthiophene) Molecule. ResearchGate. [[Link](#)]
- Yamamoto, T., et al. (2001). Synthesis and Molecular Weight Dependent Optical Properties of Mono-Alkoxy Substituted Polythiophenes. *Polymer Journal*, 33(8), 623-628. [[Link](#)]
- Duan, C., et al. (2023). Polythiophenes as electron donors in organic solar cells. *Energy & Environmental Science*, 16(5), 1866-1891. [[Link](#)]
- Lee, S. H., et al. (2021). Molecular Weight-Dependent Physical and Photovoltaic Properties of Poly(3-alkylthiophene)s with Butyl, Hexyl, and Octyl Side-Chains. *Polymers*, 13(19), 3418. [[Link](#)]
- Catellani, M., et al. (2017). π -Stacking Signature in NMR Solution Spectra of Thiophene-Based Conjugated Polymers. *ACS Omega*, 2(7), 3848-3857. [[Link](#)]
- Liu, J., et al. (2014). High thermal conductivity of chain-oriented amorphous polythiophene. *Nature Nanotechnology*, 9(4), 251-255. [[Link](#)]

- Singh, R., et al. (2009). Direct Current Conductivity Studies on Poly (3-methyl thiophene). ResearchGate. [\[Link\]](#)
- Pauldine, J. R. (2016). Assessment of Purification Methods for the Removal of Endotoxins from Polymers Generated by E. coli. Experts at ESF. [\[Link\]](#)
- Yamamoto, T., et al. (1998). Extensive Studies on π -Stacking of Poly(3-alkylthiophene-2,5-diyl)s and Poly(4-alkylthiazole-2,5-diyl)s by Optical Spectroscopy, NMR Analysis, Light Scattering Analysis, and X-ray Crystallography. Journal of the American Chemical Society, 120(9), 2047-2058. [\[Link\]](#)
- Duan, C., et al. (2023). Polythiophenes as electron donors in organic solar cells. Energy & Environmental Science, 16(5), 1866-1891. [\[Link\]](#)
- Bridges, C. R., et al. (2021). Enabling Conducting Polymer Applications: Methods for Achieving High Molecular Weight in Chemical Oxidative Polymerization in Alkyl- and Ether-Substituted Thiophenes. Polymers, 13(20), 3585. [\[Link\]](#)
- Aydin, E., et al. (2018). Solvent free chemical oxidative polymerization as a universal method for the synthesis of ultra high molecular weight conjugated polymers based on 3,4-propylenedioxythiophenes. Polymer Chemistry, 9(3), 317-321. [\[Link\]](#)
- Kim, M., et al. (2021). Controlled Synthesis of Poly[(3-alkylthio)thiophene]s and Their Application to Organic Field-Effect Transistors. ACS Applied Materials & Interfaces, 13(26), 31898-31908. [\[Link\]](#)
- Jabbar, A. H. (2015). Synthesis and Characterization of poly(3-hexylthiophene). International Journal of Advanced Research in Physical Science, 2(10), 1-7. [\[Link\]](#)
- de Oliveira, F. F., et al. (2018). Influence of solvent used on oxidative polymerization of Poly(3-hexylthiophene) in their chemical properties. Polímeros, 28(4), 363-368. [\[Link\]](#)
- Zhang, J., et al. (2022). Ternary organic solar cells featuring polythiophene. OAE Publishing Inc. [\[Link\]](#)
- Zhang, Y., et al. (2019). Selective Removal of Thiophene Using Surface Molecularly Imprinted Polymers Based on β -Cyclodextrin Porous Carbon Nanospheres and

Polycarboxylic Acid Functional Monomers. *Energy & Fuels*, 33(12), 12896-12906. [[Link](#)]

- Lim, S. L. (2013). Poly(3-hexylthiophene) nanofibers for organic photovoltaic applications. DR-NTU. [[Link](#)]
- Caban-Malo, P., et al. (2011). Poly(3-alkylthiophenes): New Sorption Materials for Solid Phase Microextraction of Drugs Isolated From Human Plasma. *Analytical Letters*, 44(10), 1839-1851. [[Link](#)]
- Carle, J. E., et al. (2018). Effect of poly(thiophene)s topology on their third-order nonlinear optical response. *Lirias*. [[Link](#)]
- Kiatnapan, A., et al. (2022). Synthesis of Highly Conductive Poly(3-hexylthiophene) by Chemical Oxidative Polymerization Using Surfactant Templates. *Polymers*, 14(18), 3848. [[Link](#)]
- de Oliveira, F. F., et al. (2018). Influence of solvent used on oxidative polymerization of Poly(3-hexylthiophene) in their chemical properties. *ResearchGate*. [[Link](#)]

Need Custom Synthesis?

BenchChem offers custom synthesis for rare earth carbides and specific isotopic labeling.

Email: info@benchchem.com or [Request Quote Online](#).

Sources

- [1. researchgate.net \[researchgate.net\]](https://www.researchgate.net)
- [2. Polythiophenes as electron donors in organic solar cells - Chemical Science \(RSC Publishing\) \[pubs.rsc.org\]](https://pubs.rsc.org)
- [3. cpsm.kpi.ua \[cpsm.kpi.ua\]](https://cpsm.kpi.ua)
- [4. scielo.br \[scielo.br\]](https://scielo.br)
- [5. Preparation, characterization, and magnetic properties of poly\(3-methoxythiophene\)-Fe 3 O 4 conducting nanocomposite - Polymer Chemistry \(RSC Publishing\) DOI:10.1039/D5PY00933B \[pubs.rsc.org\]](https://pubs.rsc.org)
- [6. researchgate.net \[researchgate.net\]](https://www.researchgate.net)

- [7. s3.amazonaws.com \[s3.amazonaws.com\]](https://s3.amazonaws.com)
- [8. Solid-State Synthesis of Poly\(3',4'-dimethoxy-2,2':5',2"- terthiophene\): Comparison With Poly\(terthiophene\) and Poly\(3',4'-ethylenedioxy-2,2':5',2"- terthiophene\) \[mdpi.com\]](#)
- [9. mdpi.com \[mdpi.com\]](#)
- [10. Electrosynthesis and characterization of poly\(3-methoxythiophene\)–polybithiophene composite films prepared in micellar media on Pt and Fe substrates - Physical Chemistry Chemical Physics \(RSC Publishing\) \[pubs.rsc.org\]](#)
- [11. spij.jp \[spij.jp\]](#)
- [12. mdpi.com \[mdpi.com\]](#)
- [13. pubs.acs.org \[pubs.acs.org\]](#)
- [14. rsc.org \[rsc.org\]](#)
- [15. \$\Pi\$ -Stacking Signature in NMR Solution Spectra of Thiophene-Based Conjugated Polymers - PMC \[pmc.ncbi.nlm.nih.gov\]](#)
- [16. pdfs.semanticscholar.org \[pdfs.semanticscholar.org\]](#)
- [17. homepage.ntu.edu.tw \[homepage.ntu.edu.tw\]](#)
- [18. 3-Methoxythiophene\(17573-92-1\) 1H NMR \[m.chemicalbook.com\]](#)
- [19. pubs.acs.org \[pubs.acs.org\]](#)
- To cite this document: BenchChem. [Synthesis of Poly(3-methoxythiophene): A Detailed Guide for Organic Electronics Applications]. BenchChem, [2026]. [Online PDF]. Available at: [<https://www.benchchem.com/product/b8618683/docs#synthesis-of-poly-3-methoxythiophene-a-detailed-guide-for-organic-electronics-applications>]

Disclaimer & Data Validity:

The information provided in this document is for Research Use Only (RUO) and is strictly not intended for diagnostic or therapeutic procedures. While BenchChem strives to provide accurate protocols, we make no warranties, express or implied, regarding the fitness of this product for every specific experimental setup.

Technical Support: The protocols provided are for reference purposes. Unsure if this reagent suits your experiment?

Need Industrial/Bulk Grade? [Request Custom Synthesis Quote](#)

BenchChem

Our mission is to be the trusted global source of essential and advanced chemicals, empowering scientists and researchers to drive progress in science and industry.

Contact

Address: 3281 E Guasti Rd

Ontario, CA 91761, United States

Phone: (601) 213-4426

Email: info@benchchem.com

[Contact our Ph.D. Support Team for a compatibility check](#)