

Mass Spectrometry Fragmentation Pattern of Chlorinated Triazoles: A Technical Guide

Author: BenchChem Technical Support Team. **Date:** April 2026

Compound of Interest

Compound Name: 4-(2-Chlorophenyl)-1*h*-1,2,3-triazole

Cat. No.: B8616485

[Get Quote](#)

Executive Summary

Chlorinated triazoles (e.g., tebuconazole, propiconazole, epoxiconazole) represent a critical class of ergosterol biosynthesis inhibitors used extensively in agriculture and clinical mycology. [1] In mass spectrometry (MS), these compounds exhibit a distinct isotopic signature and fragmentation topology that differentiates them from non-chlorinated analogs.[1]

This guide moves beyond basic spectral interpretation to analyze the mechanistic drivers of fragmentation. We compare chlorinated triazoles against non-chlorinated alternatives, providing a self-validating experimental protocol designed to minimize false positives in complex matrices.

Theoretical Framework: The "Chlorine Effect"

The defining feature of chlorinated triazoles in MS is not merely their mass-to-charge (

) ratio, but their isotopic abundance pattern.[1][2] Unlike non-chlorinated azoles (which rely primarily on

ratios), chlorinated compounds carry a diagnostic "fingerprint" due to the natural abundance of

Chlorine-35 () and Chlorine-37 ().

Isotopic Validation Logic

- Single Chlorine (): Produces a characteristic and cluster with an intensity ratio of approximately 3:1.
- Double Chlorine (): Produces a cluster of , , and with ratios of 9:6:1.[1]

Insight: This isotopic pattern serves as an internal "validity check." If your precursor ion does not match these theoretical intensity ratios within

, the peak is likely a matrix interference, regardless of retention time.[1]

Comparative Analysis: Chlorinated vs. Non-Chlorinated Triazoles

The following table contrasts the MS behavior of a representative chlorinated triazole (Tebuconazole) against a non-chlorinated analog (Fluconazole - note: Fluconazole contains Fluorine, which is monoisotopic, effectively behaving like a non-chlorinated species regarding isotopic clustering).

Table 1: Performance and Spectral Comparison

Feature	Chlorinated Triazoles (e.g., Tebuconazole)	Non-Chlorinated/Fluoro-Triazoles (e.g., Fluconazole)
Isotopic Signature	Distinct Multi-Peak Cluster. and (3:[1]1) or (9:6:1). Allows for "Isotope Filtering" in data processing.[1] [3]	Single Dominant Peak. Only minor () contributions. Harder to distinguish from isobaric background noise.[1]
Primary Fragmentation	Heterolytic C-N Cleavage. The bond between the triazole ring and the chlorinated alkyl side chain breaks.	Triazole Ring Cleavage. Often involves internal scission of the triazole ring itself or loss of hydroxyl groups.
Diagnostic Fragment	70 (Triazole Ring) & Chlorinated Carbocation. The side chain retains the Cl pattern.	124 (Triazole derivative). Lacks the confirming isotopic split in the fragment spectrum.
Ionization Efficiency	High (ESI+). The basic nitrogen in the triazole ring protonates readily ()).	Moderate to High (ESI+). Similar protonation, but often requires higher source voltage for optimal transmission.[1]
Matrix Interference	Low. The unique mass defect of Cl (negative mass defect) shifts peaks away from nominal hydrocarbon background.	High. Mass defect is closer to endogenous biological lipids/peptides, increasing risk of overlap.[1]

Mechanistic Fragmentation Pathway

Understanding why fragmentation occurs allows for better method development.[1] In Electrospray Ionization (ESI), the protonated molecular ion

typically undergoes Charge-Site Initiated Fragmentation.[1]

Mechanism:

- Protonation: The N4 or N2 nitrogen of the 1,2,4-triazole ring accepts a proton.[1]
- C-N Bond Scission: The bond connecting the triazole ring to the central carbon scaffold is the "weakest link" relative to the stable aromatic chlorophenyl group.
- Charge Retention:
 - Pathway A (Common): The charge remains on the triazole ring, yielding a characteristic ion at m/z 70 (1,2,4-triazole cation).[1]
 - Pathway B (Structure Specific): The charge remains on the chlorinated benzyl/alkyl carbocation. This fragment is crucial for confirmation because it retains the chlorine isotopic pattern.

Visualization: Fragmentation Topology

The following diagram illustrates the competing fragmentation pathways for a generic chlorinated triazole.

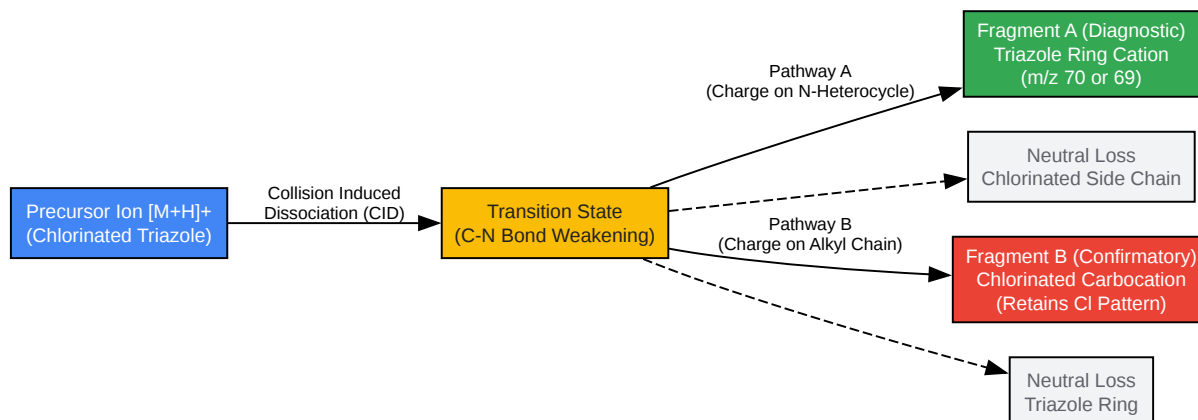

[Click to download full resolution via product page](#)

Figure 1: Competing fragmentation pathways in ESI-MS/MS. Pathway A yields the generic triazole marker (

70), while Pathway B provides the specific chlorinated fingerprint.

Experimental Protocol: Self-Validating LC-MS/MS Workflow

This protocol is designed for the quantification of chlorinated triazoles in complex matrices (e.g., plasma or agricultural runoff).[1] It incorporates a "Dual-Transition + Isotope Check" step to ensure data integrity.

Equipment Prerequisites

- LC System: UHPLC (e.g., Agilent 1290 or equivalent).[1]
- MS System: Triple Quadrupole (QqQ) or Q-TOF.
- Column: C18 Reverse Phase (e.g., Zorbax Eclipse Plus, 1.8 μm).[1]

Step-by-Step Methodology

Phase 1: Sample Preparation (QuEChERS Modified)

- Extraction: Mix 10 mL sample with 10 mL Acetonitrile (ACN).
- Salting Out: Add 4g MgSO_4 and 1g NaCl . Vortex vigorously for 1 min.
- Centrifugation: Spin at 4000 rpm for 5 min.
- Clean-up: Transfer supernatant to d-SPE tube (PSA + C18). Vortex and centrifuge.[4]

Phase 2: LC-MS/MS Parameters[1]

- Mobile Phase A: Water + 0.1% Formic Acid + 5mM Ammonium Formate (Ammonium aids ionization).
- Mobile Phase B: Methanol + 0.1% Formic Acid.[1]
- Gradient: 5% B to 95% B over 10 mins.

- Ionization: ESI Positive Mode (

).[5]

Phase 3: The "Self-Validating" Acquisition Strategy

Do not just monitor one transition. Set up the following Multiple Reaction Monitoring (MRM) logic:

Analyte	Precursor ()	Product ()	Purpose	Validation Criteria
Tebuconazole	308.2 ()	70.1	Quantifier	High intensity, generic triazole fragment.[1]
	308.2 ()	125.0	Qualifier 1	Chlorobenzyl fragment. Must exist.
	310.2 ()	70.1	Isotope Check	CRITICAL: Intensity must be ~33% of the Quantifier trace.

Why this works: If a background interference co-elutes at

308, it is statistically improbable that it also has a co-eluting interference at

310 with exactly 33% intensity.[1] This confirms the presence of Chlorine.

Workflow Visualization

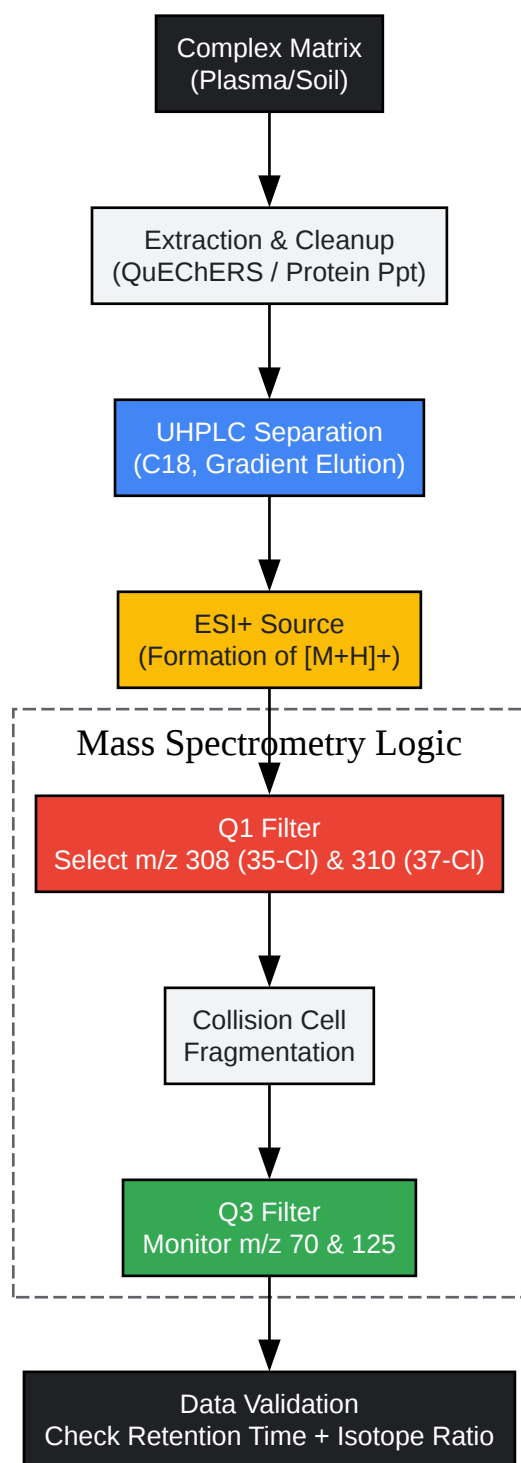

[Click to download full resolution via product page](#)

Figure 2: End-to-end workflow for high-fidelity detection of chlorinated triazoles.[1]

References

- Springer Nature Experiments.Triazole Antifungal Quantification for Therapeutic Drug Monitoring in Serum by LC-MS/MS. Available at: [[Link](#)]
- National Institutes of Health (PubMed).Characterization of MS/MS Product Ions for the Differentiation of Structurally Isomeric Pesticides. Available at: [[Link](#)]
- Chemistry Steps.Isotopes in Mass Spectrometry: The Chlorine and Bromine Signature. Available at: [[Link](#)]
- Agilent Technologies.Using a Chlorine Filter for Accurate-Mass Data Analysis of Environmental Samples.[1] Available at: [[Link](#)]
- ChemGuide.Fragmentation Patterns in Mass Spectra: Mechanisms and Interpretation. Available at: [[Link](#)]

Need Custom Synthesis?

BenchChem offers custom synthesis for rare earth carbides and specific isotopic labeling.

Email: info@benchchem.com or [Request Quote Online](#).

Sources

- 1. microbiologyjournal.org [microbiologyjournal.org]
- 2. [Isotopes in Mass Spectrometry - Chemistry Steps](http://chemistrysteps.com) [chemistrysteps.com]
- 3. agilent.com [agilent.com]
- 4. lcms.cz [lcms.cz]
- 5. [Synthesis and Biological Evaluation of Novel 1,2,4-Triazole Derivatives Containing Amino Acid Fragments - PMC](http://pmc.ncbi.nlm.nih.gov) [pmc.ncbi.nlm.nih.gov]
- To cite this document: BenchChem. [Mass Spectrometry Fragmentation Pattern of Chlorinated Triazoles: A Technical Guide]. BenchChem, [2026]. [Online PDF]. Available at: [<https://www.benchchem.com/product/b8616485/docs#mass-spectrometry-fragmentation-pattern-of-chlorinated-triazoles-a-technical-guide>]

Disclaimer & Data Validity:

The information provided in this document is for Research Use Only (RUO) and is strictly not intended for diagnostic or therapeutic procedures. While BenchChem strives to provide accurate protocols, we make no warranties, express or implied, regarding the fitness of this product for every specific experimental setup.

Technical Support: The protocols provided are for reference purposes. Unsure if this reagent suits your experiment?

Need Industrial/Bulk Grade? [Request Custom Synthesis Quote](#)

BenchChem

Our mission is to be the trusted global source of essential and advanced chemicals, empowering scientists and researchers to drive progress in science and industry.

Contact

Address: 3281 E Guasti Rd
Ontario, CA 91761, United States
Phone: (601) 213-4426
Email: info@benchchem.com

[Contact our Ph.D. Support Team for a compatibility check](#)