

Technical Guide: Optimizing Prolyl Endopeptidase Assays Using Boc-Proline Anilide

Author: BenchChem Technical Support Team. **Date:** April 2026

Compound of Interest

Compound Name: *Boc-proline anilide*

Cat. No.: *B8605926*

[Get Quote](#)

Executive Summary

In drug discovery and neurobiology, Prolyl Endopeptidase (PEP), also known as Prolyl Oligopeptidase (POP), is a critical target due to its role in metabolizing neuropeptides and its implication in neurodegenerative disorders.[1][2] While various assay formats exist, the chromogenic Boc-Pro-pNA (Boc-Prolyl-p-nitroanilide) assay remains a workhorse for kinetic profiling and inhibitor screening.

This guide provides a rigorous comparison of Boc-Pro-pNA against fluorogenic and HPLC alternatives, followed by a self-validating protocol designed to maximize reproducibility () and accuracy.

Mechanism of Action

The assay relies on the specific cleavage of the amide bond between the proline residue and the p-nitroanilide (pNA) moiety. PEP is a serine protease with a unique

-propeller domain that restricts access to oligopeptides (<30 amino acids).

Reaction Pathway

The enzyme recognizes the trans-peptide bond preceding the proline.[3] Upon hydrolysis, the chromophore pNA is released.[4] While the substrate is colorless, free pNA absorbs strongly at 405–410 nm.

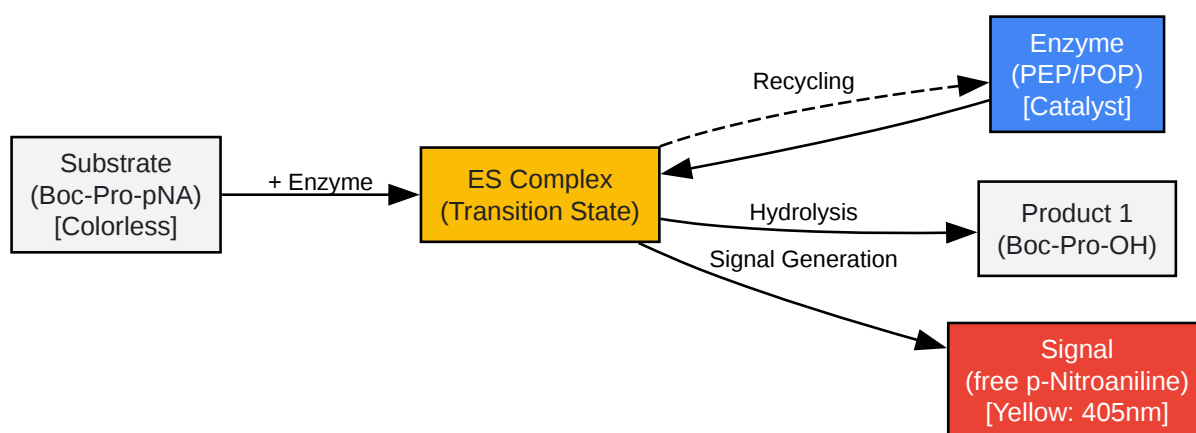

[Click to download full resolution via product page](#)

Figure 1: Enzymatic hydrolysis mechanism. The signal is generated solely by the liberation of the pNA leaving group.

Comparative Analysis: Chromogenic vs. Fluorogenic vs. HPLC

Selecting the right assay depends on the balance between sensitivity, throughput, and interference tolerance.

Feature	Boc-Pro-pNA (Chromogenic)	Z-Gly-Pro-AMC (Fluorogenic)	HPLC / LC-MS
Detection Principle	Absorbance (405 nm)	Fluorescence (Ex 380 / Em 460)	UV or Mass Spec
Sensitivity (LOD)	Low M range	Low nM to pM range	Varies (High specificity)
Throughput	High (96/384-well plate)	High (96/384-well plate)	Low (Serial injection)
Interference	Colored compounds (Inner filter effect)	Quenching / Autofluorescence	Matrix effects (Ion suppression)
Cost	Low	Moderate	High
Primary Use Case	/ determination, High-conc. inhibitor screening	Low-activity samples, cell lysates	Metabolite identification, degradation stability

Scientist's Insight: While fluorogenic assays (AMC) offer higher sensitivity, they are prone to "false positives" in library screening due to the fluorescence quenching properties of many drug-like small molecules. Boc-Pro-pNA is often preferred for primary screening because absorbance artifacts are easier to identify and correct than fluorescence quenching.

Validated Experimental Protocol

Standard protocols often fail because they rely on theoretical extinction coefficients. This protocol enforces a self-validating standard curve.

Reagents

- Assay Buffer: 100 mM Phosphate Buffer, pH 7.5, 1 mM DTT, 0.5 mM EDTA.
 - Note: DTT prevents oxidation of the active site cysteine (if present in specific isoforms) or stabilizes the enzyme structure.

- Substrate Stock: 20 mM Boc-Pro-pNA in 100% DMSO.
 - Storage: -20°C. Stable for 6 months.[5]
- pNA Standard: 10 mM p-nitroaniline in DMSO (for calibration).

Workflow Diagram

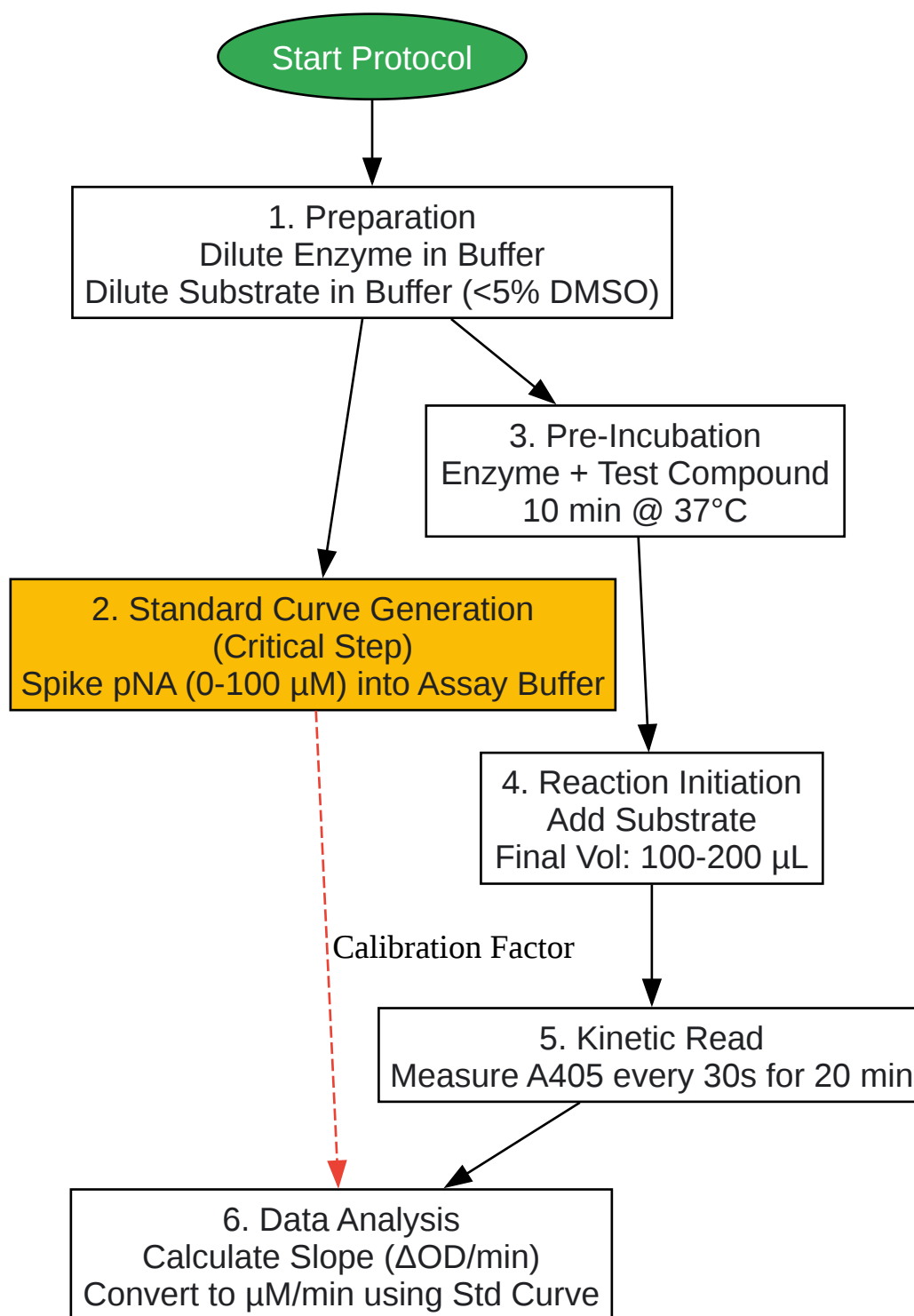

[Click to download full resolution via product page](#)

Figure 2: Step-by-step assay workflow emphasizing the parallel generation of the standard curve.

Step-by-Step Methodology

- Standard Curve Generation (The "Trust" Step):
 - Do not assume
or
.
 - Prepare serial dilutions of pure pNA (0, 10, 20, 50, 100
) in the exact assay buffer containing the same % DMSO as your samples.
 - Measure Absorbance at 405 nm.[\[4\]](#)[\[6\]](#)
 - Plot OD vs. Concentration.[\[4\]](#)[\[7\]](#) The slope is your experimental extinction coefficient ().
- Enzyme Preparation:
 - Dilute PEP to a concentration where the reaction remains linear for at least 15 minutes. A target
of 0.01 – 0.05 is ideal.
- Reaction Setup (96-well plate):
 - Blank: 180
Buffer + 20
Substrate.
 - Control: 160
Buffer + 20
Enzyme + 20

Solvent (DMSO).

- Test: 160

Buffer + 20

Enzyme + 20

Inhibitor.

- Kinetic Measurement:
 - Pre-warm plate to 37°C.
 - Add Substrate to initiate.
 - Read continuously at 405 nm for 20 minutes.

Data Analysis & Reproducibility

Calculating Activity

Do not use endpoint readings for enzymatic assays if possible; kinetic reads reduce noise.

Note: If using the standard curve slope directly, the pathlength is already accounted for.

Troubleshooting & Optimization (The "Senior Scientist" Check)

Issue	Probable Cause	Solution
Non-linear progress curve	Substrate depletion (>10% conversion)	Dilute enzyme or reduce measurement time.
High Background	Substrate instability	Check spontaneous hydrolysis in "Blank" wells. Freshly prepare substrate.
Low Z-Factor (<0.5)	Pipetting error or DMSO inhomogeneity	Pre-mix DMSO/Substrate before adding to wells. Use a multichannel pipette.
Signal Drift	Temperature fluctuation	Ensure plate reader is pre-warmed to 37°C. Cold buffers cause condensation.

Reproducibility Metrics

To ensure the assay is robust for screening:

- Z'-Factor: Must be .
- DMSO Tolerance: PEP is generally stable up to 5-10% DMSO, but this must be validated for your specific enzyme source (recombinant vs. tissue).
- Coefficient of Variation (CV): Intra-plate CV should be .

References

- Polgár, L. (2002). The prolyl oligopeptidase family.[2][7][8] Cellular and Molecular Life Sciences, 59(2), 349–362. Retrieved from [[Link](#)]
- Lottenberg, R., et al. (1983). Solution composition dependent variation in extinction coefficients for p-nitroaniline.[9] Biochimica et Biophysica Acta, 742(3), 558-564.[9] Retrieved

from [\[Link\]](#)

Need Custom Synthesis?

BenchChem offers custom synthesis for rare earth carbides and specific isotopic labeling.

Email: info@benchchem.com or [Request Quote Online](#).

Sources

- 1. Comparative analysis of the substrate preferences of two post-proline cleaving endopeptidases, prolyl oligopeptidase and fibroblast activation protein α - PMC [[pmc.ncbi.nlm.nih.gov](https://pubmed.ncbi.nlm.nih.gov/16111111/)]
- 2. Structural and mechanistic analysis of two prolyl endopeptidases: Role of interdomain dynamics in catalysis and specificity - PMC [[pmc.ncbi.nlm.nih.gov](https://pubmed.ncbi.nlm.nih.gov/16111111/)]
- 3. [sinobiological.com](https://www.sinobiological.com/) [[sinobiological.com](https://www.sinobiological.com/)]
- 4. [pdf.benchchem.com](https://www.pdf.benchchem.com/) [[pdf.benchchem.com](https://www.pdf.benchchem.com/)]
- 5. [sigmaaldrich.com](https://www.sigmaaldrich.com/) [[sigmaaldrich.com](https://www.sigmaaldrich.com/)]
- 6. [mdpi.com](https://www.mdpi.com/) [[mdpi.com](https://www.mdpi.com/)]
- 7. [doras.dcu.ie](https://www.doras.dcu.ie/) [[doras.dcu.ie](https://www.doras.dcu.ie/)]
- 8. Purification and characterization of a Z-pro-prolinal-insensitive Z-Gly-Pro-7-amino-4-methyl coumarin-hydrolyzing peptidase from bovine serum--a new proline-specific peptidase - PubMed [[pubmed.ncbi.nlm.nih.gov](https://pubmed.ncbi.nlm.nih.gov/16111111/)]
- 9. Solution composition dependent variation in extinction coefficients for p-nitroaniline - PubMed [[pubmed.ncbi.nlm.nih.gov](https://pubmed.ncbi.nlm.nih.gov/16111111/)]
- To cite this document: BenchChem. [Technical Guide: Optimizing Prolyl Endopeptidase Assays Using Boc-Proline Anilide]. BenchChem, [2026]. [Online PDF]. Available at: [<https://www.benchchem.com/product/b8605926/docs#technical-guide-optimizing-prolyl-endopeptidase-assays-using-boc-proline-anilide>]

Disclaimer & Data Validity:

The information provided in this document is for Research Use Only (RUO) and is strictly not intended for diagnostic or therapeutic procedures. While BenchChem strives to provide

accurate protocols, we make no warranties, express or implied, regarding the fitness of this product for every specific experimental setup.

Technical Support: The protocols provided are for reference purposes. Unsure if this reagent suits your experiment?

Need Industrial/Bulk Grade? [Request Custom Synthesis Quote](#)

BenchChem

Our mission is to be the trusted global source of essential and advanced chemicals, empowering scientists and researchers to drive progress in science and industry.

Contact

Address: 3281 E Guasti Rd

Ontario, CA 91761, United States

Phone: (601) 213-4426

Email: info@benchchem.com

[Contact our Ph.D. Support Team for a compatibility check](#)