

acid-catalyzed spiroketalization protocols

Author: BenchChem Technical Support Team. **Date:** May 2026

Compound of Interest

Compound Name: 7,12-Dioxaspiro[5.6]dodecane

CAS No.: 181-28-2

Cat. No.: B086791

[Get Quote](#)

Introduction: The Spiroketal Imperative

Spiroketals are privileged structural motifs found in a vast array of bioactive natural products, including marine toxins (e.g., spongistatins, azaspiracids) and macrolide antibiotics (e.g., avermectins, milbemycins). Their rigid 3D architecture often serves as a scaffold for displaying pharmacophores.

For the synthetic chemist, the challenge lies in stereocontrol. The spirocenter configuration is governed by a delicate balance between thermodynamic stability (driven by the anomeric effect) and kinetic accessibility. This guide details two orthogonal protocols:

- Thermodynamic Equilibration: Using Brønsted acids to access the most stable "double anomeric" isomer.
- Kinetic Trapping: Using Gold(I) catalysis to access non-thermodynamic isomers from alkynyl diols.

Mechanistic Foundations: The Anomeric Effect

To control the reaction, one must understand the underlying electronic forces. The stability of spiroketals is dictated by the anomeric effect, which describes the preference for electronegative substituents at the anomeric position to adopt an axial orientation.[1]

- Electronic Origin: Stabilizing hyperconjugation between the non-bonding lone pair of the ring oxygen () and the antibonding orbital of the adjacent C-O bond ().[1][2]
- Thermodynamic Hierarchy:
 - Double Anomeric (Most Stable): Both oxygens are axial relative to the other ring. (stabilization).
 - Single Anomeric: One oxygen is axial, one equatorial.[3]
 - Non-Anomeric (Least Stable): Both oxygens are equatorial (often sterically favored but electronically disfavored).

Visualization: The Thermodynamic Landscape

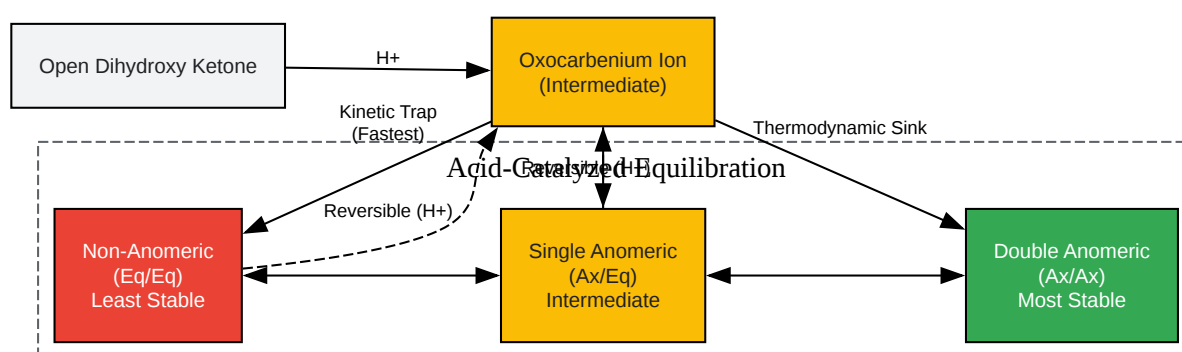

[Click to download full resolution via product page](#)

Figure 1: Reaction coordinate showing the transition from open chain to the thermodynamic sink (Double Anomeric) via oxocarbenium intermediates.

Protocol A: Thermodynamic Control (Brønsted Acid)

Objective: Synthesis of the thermodynamically most stable spiroketal isomer (typically the [6,6]-cis-ketal stabilized by the double anomeric effect).

Scope: Suitable for substrates where the target natural product corresponds to the most stable isomer (e.g., the spirocenter in milbemycin).

Reagent Selection Guide

Catalyst	Strength ()	Application Context
CSA (Camphorsulfonic acid)	Strong Organic	Standard. Soluble in organic solvents; easy to handle.
pTSA (p-Toluenesulfonic acid)	Strong Organic	Aggressive. Use for sterically hindered ketones.
PPTS (Pyridinium p-toluenesulfonate)	Weak	Mild. Use when acid-sensitive protecting groups (e.g., TES, TBS) are present.
HCl / MeOH	Strong Inorganic	Global Deprotection. Cleaves silyl ethers concomitant with spiroketalization.

Step-by-Step Methodology

- Preparation: Dissolve the dihydroxy ketone precursor (1.0 equiv) in anhydrous Dichloromethane (DCM) or Benzene (0.05 M).
 - Note: DCM is standard. Benzene is used if water removal (Dean-Stark) is required to drive the equilibrium, though molecular sieves are preferred in modern contexts.
- Acid Initiation: Add CSA (0.1 – 0.3 equiv) at .
- Equilibration: Warm to Room Temperature (RT) and stir.

- Critical Checkpoint: Monitor by TLC. You may initially see multiple spots (kinetic isomers) coalescing into a single major spot (thermodynamic product) over 1–4 hours.
- Completion: If conversion is incomplete, add activated 4Å Molecular Sieves to sequester water, driving the equilibrium forward.
- Quench: Add saturated aqueous

or

(excess) to neutralize the acid before concentration.
 - Warning: Concentrating an acidic solution can lead to decomposition or reversion.
- Purification: Flash column chromatography on silica gel (buffered with 1%

if the spiroketal is acid-sensitive).

Protocol B: Kinetic/Orthogonal Control (Gold Catalysis)

Objective: Accessing spiroketals from alkynyl diols often allowing access to kinetic isomers or substrates incompatible with harsh Brønsted acids.

Mechanism: Gold(I) acts as a

-acid, activating the alkyne for nucleophilic attack by the hydroxyl group. This process is often irreversible under the reaction conditions, trapping the kinetic product.

Workflow Logic

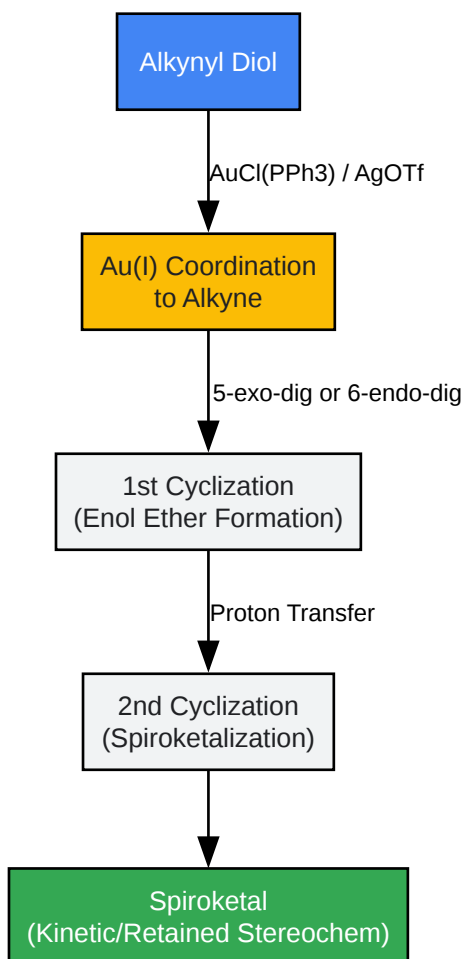

[Click to download full resolution via product page](#)

Figure 2: Gold-catalyzed cascade for alkynyl diol spiroketalization.

Step-by-Step Methodology

- Catalyst Preparation: In a glovebox or under Argon, weigh (5 mol%) and (5 mol%).
 - Why Silver? AgOTf abstracts the chloride from Gold, generating the active cationic species

- Solvent System: Dissolve the alkynyl diol in deoxygenated DCM or Toluene (0.1 M).
 - Note: Methanol can be used to speed up proton transfer steps but may participate in side reactions.
- Reaction: Add the catalyst mixture to the substrate solution at RT. Protect from light (silver salts are photosensitive).
- Monitoring: Reaction is typically fast (30 min – 2 hours).
- Workup: Filter the mixture through a short pad of Celite to remove metal salts. Concentrate and purify.

Troubleshooting & Self-Validation

To ensure scientific integrity, every experiment must be self-validating. Use these checkpoints:

Observation	Diagnosis	Corrective Action
Product is a 1:1 mixture of isomers	Equilibrium not reached OR no thermodynamic preference.	1. Extend reaction time. 2. Switch to reflux in Benzene. 3. Check molecular modeling: Is there a significant energy difference ()?)?
Reversion during purification	Silica gel acidity is catalyzing isomerization.	Pre-treat silica column with 1% / Hexanes.
Low conversion (Gold Protocol)	Catalyst poisoning (often by amines or thiols).	Ensure substrate is free of coordinating groups. Increase catalyst loading to 10 mol%.
Hydrolysis of acetal	Water entering the system.	Strictly anhydrous conditions. Add 4Å Molecular Sieves.

References

- Deslongchamps, P. (1983).[4] Stereoelectronic Effects in Organic Chemistry. Pergamon Press.[4] (Foundational text on the anomeric effect).
- Perron, F., & Albizati, K. F. (1989). Chemistry of Spiroketal. Chemical Reviews, 89(7), 1617–1661. [Link](#)
- Aponick, A., et al. (2010). Gold-Catalyzed Synthesis of Spiroketal. Journal of the American Chemical Society, 132(2), 460-461. (Seminal paper on Au-catalyzed alkynol cyclization). [Link](#)
- Brimble, M. A., & Fares, F. A. (1999). Spiroketal Synthesis via Oxidative Radical Cyclization. Tetrahedron, 55(36), 10879-10898. [Link](#)
- Trost, B. M., & O'Boyle, B. M. (2008). Palladium-Catalyzed Asymmetric Synthesis of Spiroketal. Journal of the American Chemical Society, 130(48), 16190-16192. [Link](#)

Need Custom Synthesis?

BenchChem offers custom synthesis for rare earth carbides and specific isotopic labeling.

Email: info@benchchem.com or [Request Quote Online](#).

Sources

- 1. pubs.acs.org [pubs.acs.org]
- 2. [researchgate.net](https://www.researchgate.net) [[researchgate.net](https://www.researchgate.net)]
- 3. Recent Synthetic Approaches Toward Non-anomeric Spiroketal in Natural Products - PMC [[pmc.ncbi.nlm.nih.gov](https://pubmed.ncbi.nlm.nih.gov/)]
- 4. [scispace.com](https://www.scispace.com) [[scispace.com](https://www.scispace.com)]
- To cite this document: BenchChem. [acid-catalyzed spiroketalization protocols]. BenchChem, [2026]. [Online PDF]. Available at: [<https://www.benchchem.com/product/b086791/docs#acid-catalyzed-spiroketalization-protocols>]

Disclaimer & Data Validity:

The information provided in this document is for Research Use Only (RUO) and is strictly not intended for diagnostic or therapeutic procedures. While BenchChem strives to provide accurate protocols, we make no warranties, express or implied, regarding the fitness of this product for every specific experimental setup.

Technical Support: The protocols provided are for reference purposes. Unsure if this reagent suits your experiment?

Need Industrial/Bulk Grade? [Request Custom Synthesis Quote](#)

BenchChem

Our mission is to be the trusted global source of essential and advanced chemicals, empowering scientists and researchers to drive progress in science and industry.

Contact

Address: 3281 E Guasti Rd
Ontario, CA 91761, United States
Phone: (601) 213-4426
Email: info@benchchem.com

[Contact our Ph.D. Support Team for a compatibility check](#)