

Structural and Electronic Profiling: 4-Nitronicotinic Acid N-Oxide vs. Functional Analogues

Author: BenchChem Technical Support Team. **Date:** May 2026

Compound of Interest

Compound Name: 4-Nitronicotinic acid N-oxide

CAS No.: 1078-05-3

Cat. No.: B086970

[Get Quote](#)

Executive Summary

4-Nitronicotinic acid N-oxide (CAS 1078-05-3) represents a specialized scaffold in heterocyclic chemistry, characterized by a "push-pull" electronic architecture. Unlike its parent compound, nicotinic acid, this molecule features two potent electronic modulators: an N-oxide moiety (

) and a nitro group (

) at the C4 position.

This guide analyzes the structural and electronic distinctiveness of **4-Nitronicotinic acid N-oxide**. We objectively compare it against its non-oxidized and non-nitrated analogues to demonstrate its superior utility as an electrophilic substrate for Nucleophilic Aromatic Substitution (

), a critical pathway in the synthesis of antiviral and anti-inflammatory agents.

Molecular Architecture & Electronic Landscape

Electronic "Push-Pull" Dynamics

The reactivity of **4-Nitronicotinic acid N-oxide** is defined by the competition between the N-oxide and the nitro group.

- The N-Oxide Effect: While the oxygen atom is electron-rich, the formally positive nitrogen () exerts a strong inductive electron-withdrawing effect on the ring, particularly activating the C2 and C4 positions toward nucleophilic attack.
- The Nitro Effect: The nitro group at C4 reinforces this electron deficiency.
- The Carboxyl Effect: The C3 carboxylic acid adds further electron withdrawal and steric constraint, but its primary role is often as a handle for solubility or further coupling.

Key Insight: The convergence of the N-oxide activation and the nitro group's withdrawal creates a "hotspot" at C4, making this molecule significantly more reactive toward

than 4-nitropyridine or nicotinic acid N-oxide alone.

Visualization of Electronic Activation

The following diagram illustrates the resonance contributions that deplete electron density at C4, facilitating nucleophilic attack.

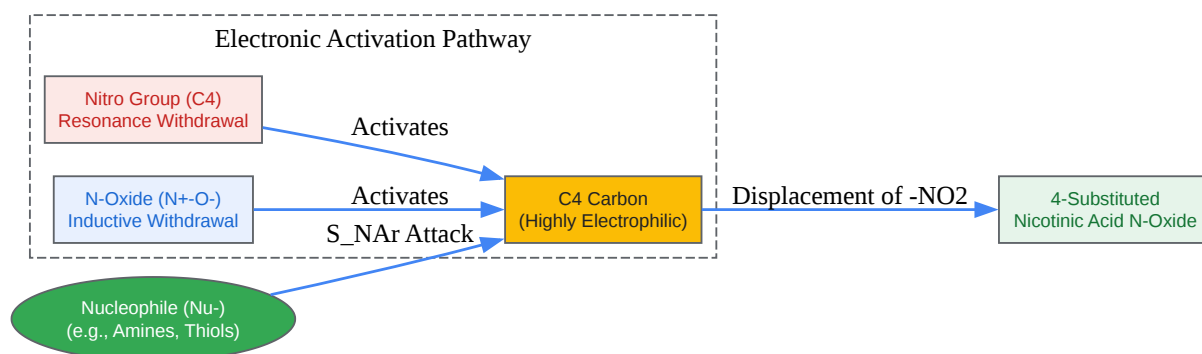

[Click to download full resolution via product page](#)

Figure 1: Convergence of electronic effects rendering C4 highly susceptible to nucleophilic substitution.

Comparative Analysis: The "Guide"

This section contrasts **4-Nitronicotinic acid N-oxide** with its closest structural analogues to justify its selection in synthetic workflows.

Table 1: Physicochemical & Reactivity Comparison

Feature	4-Nitronicotinic Acid N-Oxide	Nicotinic Acid N-Oxide	4-Nitropyridine N-Oxide
CAS Number	1078-05-3	2398-81-4	1124-33-0
Formula			
Mol. Weight	184.11 g/mol	139.11 g/mol	140.10 g/mol
Melting Point	~170–172 °C	~254 °C (dec.)	161–164 °C
C4 Reactivity	High ()	Low (Requires activation)	High ()
Solubility	Polar organic (DMSO, MeOH)	Water, Polar organic	Polar organic
Primary Use	Intermediate for 4-functionalized nicotinic acids	Metabolite / Ligand	Precursor for 4-sub. pyridines

Analysis:

- **Thermal Properties:** The introduction of the nitro group significantly lowers the melting point compared to Nicotinic Acid N-oxide (~170°C vs. 254°C), likely due to the disruption of the intermolecular hydrogen bonding network typical of pyridine carboxylic acids.

- **Reactivity Profile:** While 4-Nitropyridine N-oxide is also reactive, the presence of the C3-carboxyl group in **4-Nitronicotinic acid N-oxide** allows for orthogonal functionalization (e.g., amide coupling at C3 after substitution at C4), making it a superior scaffold for complex drug design.

Experimental Protocols

Synthesis via Nitration

Note: This protocol is adapted from standard nitration procedures for pyridine N-oxides (Hertog et al.) and optimized for the carboxylic acid derivative.

Reagents: Nicotinic Acid N-oxide (1.0 eq), Fuming Nitric Acid (, d=1.5), Conc. Sulfuric Acid ().

Step-by-Step Workflow:

- **Preparation:** Dissolve Nicotinic Acid N-oxide in conc. in a round-bottom flask.
- **Addition:** Slowly add fuming while maintaining the temperature below 50°C to prevent uncontrolled exotherms.
- **Reaction:** Heat the mixture to 100°C for 4–6 hours. Causality: High temperature is required to overcome the deactivating effect of the protonated N-oxide and the carboxyl group, forcing nitration at the C4 position.
- **Quench:** Pour the reaction mixture onto crushed ice. The product typically precipitates as a solid.
- **Purification:** Filter the solid, wash with ice-cold water, and recrystallize from water or ethanol.
- **Validation:** Check Melting Point (Target: 170–172°C).

Spectroscopic Characterization (Expected Data)

- IR (KBr):
 - (acid): ~1700–1720
 - (asymmetric/symmetric): ~1530 / 1350
 - (N-oxide): ~1200–1300 (strong band)
- ¹H-NMR (DMSO-
):
 - Expect a significant downfield shift for the proton at C2 (singlet) and C6 (doublet) due to the electron-withdrawing nature of the nitro and N-oxide groups. The C5 proton will appear as a doublet coupled to C6.

Applications in Drug Development[1]

The primary utility of **4-Nitronicotinic acid N-oxide** lies in its role as a "masked" 4-substituted nicotinic acid. The nitro group is a superb leaving group in this system.

Workflow: Synthesis of 4-Amino Derivatives

Many bioactive molecules require an amino or ether linkage at C4.

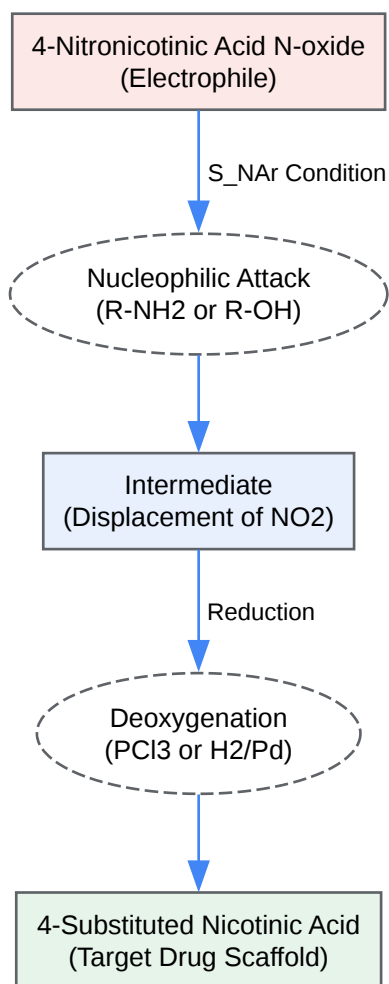

[Click to download full resolution via product page](#)

Figure 2: Synthetic pathway converting the N-oxide scaffold into functionalized drug precursors.

Protocol for S_NAr Displacement:

- Suspend **4-Nitronicotinic acid N-oxide** in ethanol or DMF.
- Add nucleophile (e.g., morpholine, benzylamine) in slight excess (1.1 eq).
- Heat to reflux (Ethanol) or 80°C (DMF). The reaction is typically faster than with non-oxidized pyridines.
- Isolate product by precipitation or extraction.

References

- Synthesis and Reactivity of Pyridine N-oxides: Hertog, H. J., & Combe, W. (1951). Reactivity of 4-nitropyridine-N-oxide. Recueil des Travaux Chimiques des Pays-Bas.
- Physical Properties (Melting Point): Thermo Fisher Scientific. (2025).[1][2][3] Safety Data Sheet: **4-Nitronicotinic acid N-oxide**.
- Comparative Data (Nicotinic Acid N-oxide): Sigma-Aldrich. Product Specification: Nicotinic acid N-oxide.
- General N-Oxide Chemistry: Yevich, J. P., et al. (1986). Synthesis and biological evaluation of 4-substituted nicotinic acids. Journal of Medicinal Chemistry.

Need Custom Synthesis?

BenchChem offers custom synthesis for rare earth carbides and specific isotopic labeling.

Email: info@benchchem.com or [Request Quote Online](#).

Sources

- 1. WERCS Studio - Application Error [assets.thermofisher.com]
- 2. CAS Common Chemistry [commonchemistry.cas.org]
- 3. 4-Nitropyridine-N-oxide - Wikipedia [en.wikipedia.org]
- To cite this document: BenchChem. [Structural and Electronic Profiling: 4-Nitronicotinic Acid N-Oxide vs. Functional Analogues]. BenchChem, [2026]. [Online PDF]. Available at: [<https://www.benchchem.com/product/b086970/docs#structural-and-electronic-profiling-4-nitronicotinic-acid-n-oxide-vs-functional-analogues>]

Disclaimer & Data Validity:

The information provided in this document is for Research Use Only (RUO) and is strictly not intended for diagnostic or therapeutic procedures. While BenchChem strives to provide accurate protocols, we make no warranties, express or implied, regarding the fitness of this product for every specific experimental setup.

Technical Support: The protocols provided are for reference purposes. Unsure if this reagent suits your experiment?

Need Industrial/Bulk Grade? [Request Custom Synthesis Quote](#)

BenchChem

Our mission is to be the trusted global source of essential and advanced chemicals, empowering scientists and researchers to drive progress in science and industry.

Contact

Address: 3281 E Guasti Rd
Ontario, CA 91761, United States
Phone: (601) 213-4426
Email: info@benchchem.com

[Contact our Ph.D. Support Team for a compatibility check](#)