

# Application Note & Protocol: A Comprehensive Guide to the Synthesis of Tricyclodecenyl Acetate

**Author:** BenchChem Technical Support Team. **Date:** May 2026

## Compound of Interest

Compound Name:	<i>3a,4,5,6,7,7a-Hexahydro-4,7-methano-1H-inden-5-ol</i>
CAS No.:	133-21-1
Cat. No.:	B086801

[Get Quote](#)

## Abstract

This document provides a detailed protocol and in-depth scientific rationale for the synthesis of tricyclodecenyl acetate, a key fragrance ingredient valued for its complex woody and green aroma.[1] Primarily targeting researchers and process development chemists, this guide elucidates the acid-catalyzed addition of acetic acid to dicyclopentadiene. We will explore the critical underlying mechanisms, including the requisite retro-Diels-Alder reaction of the starting material, and present a robust, field-proven protocol. This document emphasizes safety, efficiency, and purification strategies designed to yield a high-purity product suitable for fragrance applications.[2]

## Introduction: The Chemistry and Application of Tricyclodecenyl Acetate

Tricyclodecanyl acetate, known by trade names such as Cyclacet®, Jasmacyclene®, and Verdyl Acetate, is a widely utilized synthetic fragrance component.[3][4][5] Its chemical structure, a mixture of isomers of acetoxytricyclo[5.2.1.0<sup>2,6</sup>]decene, imparts a distinctive fresh, green, and slightly woody-fruity scent to a variety of consumer products, including perfumes, soaps, detergents, and air fresheners.[5][6]

The industrial synthesis of tricyclodecanyl acetate is an elegant example of electrophilic addition to an olefin. The process hinges on the reaction of dicyclopentadiene (DCPD) with acetic acid in the presence of a strong acid catalyst.[4] A critical, yet often overlooked, aspect of this synthesis is that commercial dicyclopentadiene exists as a dimer. It must first undergo a thermal retro-Diels-Alder reaction to generate the reactive monomer, cyclopentadiene, in situ.[7][8] This monomer then readily reacts with the acid. Understanding this equilibrium is fundamental to controlling the reaction.

This guide will provide a comprehensive methodology, from reactant preparation to final product characterization, emphasizing the scientific principles that govern each step.

## Safety & Handling

Prior to commencing any experimental work, a thorough review of the Safety Data Sheets (SDS) for all reagents is mandatory.

- Dicyclopentadiene (DCPD): Flammable liquid and vapor. Harmful if swallowed or inhaled. Causes skin and eye irritation.
- Acetic Acid (Glacial): Flammable liquid. Causes severe skin burns and eye damage.
- Trifluoromethanesulfonic Acid (Triflic Acid): Causes severe skin burns and eye damage. Reacts violently with water.
- Tricyclodecanyl Acetate: Flammable liquid.[9] Harmful to aquatic life with long-lasting effects. [9][10] Classified as a skin irritant.[6]

Personal Protective Equipment (PPE): Throughout the procedure, the following PPE must be worn:

- Chemical-resistant gloves (e.g., nitrile).[11]

- Splash-proof safety goggles and a face shield.
- Flame-retardant lab coat.[11]
- All operations should be conducted within a certified chemical fume hood with adequate ventilation.[11]

An emergency eyewash and safety shower must be readily accessible. A suitable fire extinguisher (e.g., CO<sub>2</sub>, dry chemical, or alcohol-resistant foam) should be on hand.[9][11]

## Reaction Mechanism & Scientific Principles

The synthesis of tricyclodecenyyl acetate is a two-stage process occurring concurrently in the reaction vessel.

**Stage 1: Retro-Diels-Alder Reaction** Dicyclopentadiene is the stable dimer of cyclopentadiene, formed via a spontaneous Diels-Alder reaction at room temperature.[8] To generate the reactive alkene needed for the subsequent addition reaction, DCPD must be "cracked" back into its monomeric form. This is achieved by heating the DCPD, which shifts the equilibrium back towards the starting materials.[8] This is a classic example of a retro-Diels-Alder reaction, a pericyclic process that is favored at higher temperatures.[8][12]

**Stage 2: Acid-Catalyzed Electrophilic Addition & Esterification** Once cyclopentadiene is formed, the acid catalyst (in this protocol, triflic acid) protonates the acetic acid, which then acts as an electrophile. The cyclopentadiene attacks the protonated acetic acid, leading to the formation of a carbocation intermediate. This intermediate is then attacked by an acetate anion to form the final ester product, tricyclodecenyyl acetate. The use of a strong acid catalyst like triflic acid is crucial for achieving a practical reaction rate.[3][4]

Below is a diagram illustrating the overall reaction pathway.

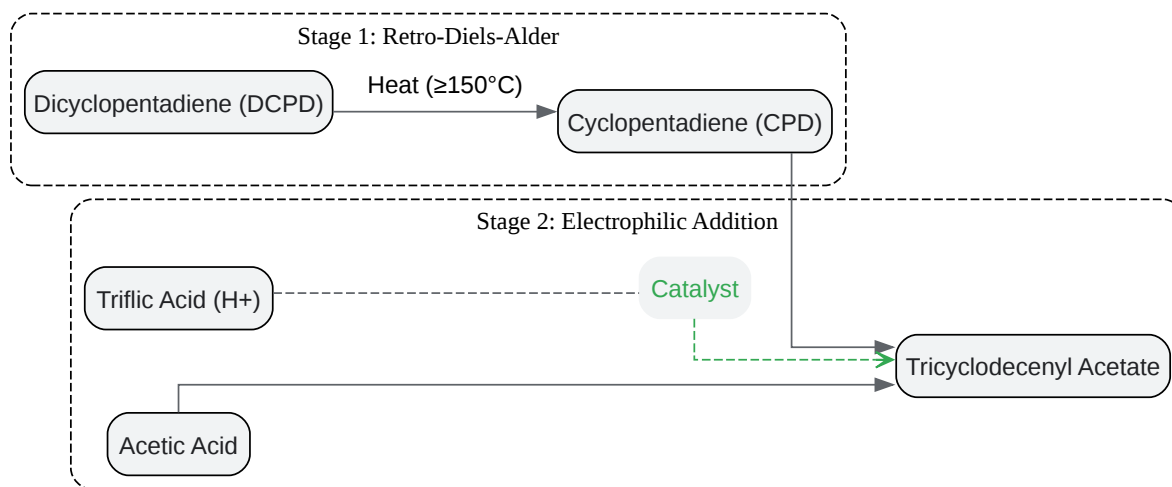

[Click to download full resolution via product page](#)

Caption: Overall reaction pathway for the synthesis of tricyclodecenyl acetate.

## Experimental Protocol

This protocol is adapted from established industrial processes, prioritizing safety and a streamlined purification process.[2][4] It avoids a traditional aqueous workup, which can lead to emulsion formation and complicates the recovery of excess reactants.[4]

## Reagents and Equipment

Reagent	CAS No.	Molecular Weight	Quantity	Moles (approx.)
Dicyclopentadiene (DCPD), ~90%	77-73-6	132.21 g/mol	147 g	1.0
Acetic Acid, Glacial	64-19-7	60.05 g/mol	63 g	1.05
Trifluoromethane sulfonic Acid	1493-13-6	150.08 g/mol	0.75 g	0.005
Sodium Hydroxide (50% aq. sol.)	1310-73-2	40.00 g/mol	0.80 g	0.01

#### Equipment:

- 500 mL three-neck round-bottom flask
- Heating mantle with a magnetic stirrer and stir bar
- Reflux condenser
- Dropping funnel
- Thermometer or thermocouple
- Distillation apparatus (fractional distillation column, condenser, receiving flasks)
- Vacuum pump and gauge

## Synthesis Procedure

The entire workflow is summarized in the diagram below.

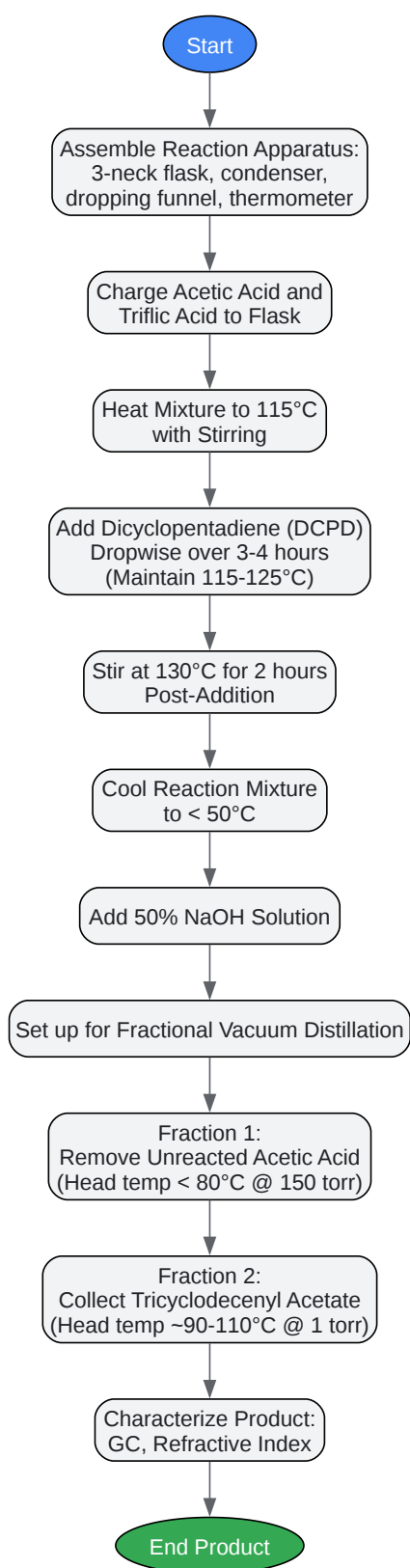

[Click to download full resolution via product page](#)

### Need Custom Synthesis?

BenchChem offers custom synthesis for rare earth carbides and specific isotopic labeling.

Email: [info@benchchem.com](mailto:info@benchchem.com) or [Request Quote Online](#).

## Sources

- [1. atamankimya.com](http://atamankimya.com) [[atamankimya.com](http://atamankimya.com)]
- [2. US7446221B1 - Process for making tricyclodecenyl esters - Google Patents](#) [[patents.google.com](http://patents.google.com)]
- [3. EP2155652A1 - Process for making tricyclodecenyl esters - Google Patents](#) [[patents.google.com](http://patents.google.com)]
- [4. WO2008153658A1 - Process for making tricyclodecenyl esters - Google Patents](#) [[patents.google.com](http://patents.google.com)]
- [5. TRICYCLODECENYL ACETATE | 2500-83-6](#) [[chemicalbook.com](http://chemicalbook.com)]
- [6. guidechem.com](http://guidechem.com) [[guidechem.com](http://guidechem.com)]
- [7. The Diels-Alder Reaction](http://cs.gordon.edu) [[cs.gordon.edu](http://cs.gordon.edu)]
- [8. masterorganicchemistry.com](http://masterorganicchemistry.com) [[masterorganicchemistry.com](http://masterorganicchemistry.com)]
- [9. capotchem.cn](http://capotchem.cn) [[capotchem.cn](http://capotchem.cn)]
- [10. olaughlinco.com](http://olaughlinco.com) [[olaughlinco.com](http://olaughlinco.com)]
- [11. chemicalbook.com](http://chemicalbook.com) [[chemicalbook.com](http://chemicalbook.com)]
- [12. Diels–Alder reaction - Wikipedia](https://en.wikipedia.org) [[en.wikipedia.org](https://en.wikipedia.org)]
- To cite this document: BenchChem. [Application Note & Protocol: A Comprehensive Guide to the Synthesis of Tricyclodecenyl Acetate]. BenchChem, [2026]. [Online PDF]. Available at: [<https://www.benchchem.com/product/b086801/docs#application-note-protocol-a-comprehensive-guide-to-the-synthesis-of-tricyclodecenyl-acetate>]

---

### Disclaimer & Data Validity:

The information provided in this document is for Research Use Only (RUO) and is strictly not intended for diagnostic or therapeutic procedures. While BenchChem strives to provide

accurate protocols, we make no warranties, express or implied, regarding the fitness of this product for every specific experimental setup.

**Technical Support:** The protocols provided are for reference purposes. Unsure if this reagent suits your experiment?

**Need Industrial/Bulk Grade?** [Request Custom Synthesis Quote](#)

## BenchChem

Our mission is to be the trusted global source of essential and advanced chemicals, empowering scientists and researchers to drive progress in science and industry.

### Contact

Address: 3281 E Guasti Rd

Ontario, CA 91761, United States

Phone: (601) 213-4426

Email: [info@benchchem.com](mailto:info@benchchem.com)

[Contact our Ph.D. Support Team for a compatibility check](#)