

Application Note: N-Boc Protection of 2-Azaspiro[4.5]decane Derivatives

Author: BenchChem Technical Support Team. **Date:** January 2026

Compound of Interest

Compound Name: 2-Azaspiro[4.5]decane

Cat. No.: B086298

[Get Quote](#)

Audience: Researchers, scientists, and drug development professionals.

Introduction

The **2-azaspiro[4.5]decane** scaffold is a privileged structural motif in medicinal chemistry, appearing in a variety of biologically active compounds targeting the central nervous system and inflammatory processes.[1][2][3] During the multi-step synthesis of complex molecules containing this scaffold, protection of the secondary amine is often a critical step to prevent unwanted side reactions. The tert-butoxycarbonyl (Boc) group is one of the most widely used protecting groups for amines due to its stability in a wide range of reaction conditions, including basic and nucleophilic environments, and its straightforward removal under mild acidic conditions.[4][5]

This application note provides a detailed, generalized protocol for the N-Boc protection of **2-Azaspiro[4.5]decane** derivatives using di-tert-butyl dicarbonate (Boc₂O).

Reaction Principle

The N-Boc protection of a secondary amine, such as a **2-Azaspiro[4.5]decane** derivative, proceeds via a nucleophilic acyl substitution. The nitrogen atom of the amine attacks one of the electrophilic carbonyl carbons of di-tert-butyl dicarbonate. This forms a tetrahedral intermediate which then collapses, yielding the N-Boc protected product along with tert-butanol and carbon dioxide as byproducts.[6] The release of CO₂ gas serves as a thermodynamic driving force for the reaction.[6]

Experimental Protocol

This protocol is a general and widely applicable method for the N-Boc protection of **2-Azaspiro[4.5]decane** derivatives.

Materials:

- **2-Azaspiro[4.5]decane** derivative (1.0 equiv)
- Di-tert-butyl dicarbonate (Boc₂O) (1.1 - 1.5 equiv)
- Solvent (e.g., Dichloromethane (DCM), Tetrahydrofuran (THF), Methanol (MeOH))
- Base (optional, e.g., Triethylamine (TEA), 4-Dimethylaminopyridine (DMAP), Sodium Bicarbonate (NaHCO₃)) (1.0 - 2.0 equiv)
- Saturated aqueous Sodium Bicarbonate (NaHCO₃) solution
- Brine (saturated aqueous NaCl solution)
- Anhydrous Magnesium Sulfate (MgSO₄) or Sodium Sulfate (Na₂SO₄)
- Round-bottom flask
- Magnetic stirrer and stir bar
- Standard laboratory glassware for extraction and filtration
- Rotary evaporator
- Thin Layer Chromatography (TLC) plates and chamber

Procedure:

- **Dissolution:** In a clean, dry round-bottom flask, dissolve the **2-Azaspiro[4.5]decane** derivative (1.0 equiv) in an appropriate solvent (e.g., Dichloromethane).
- **Base Addition (Optional):** If a base is used, add it to the solution and stir for several minutes at room temperature.^[6] For reactions sensitive to temperature changes, the mixture can be

cooled in an ice bath.[6]

- Reagent Addition: Slowly add di-tert-butyl dicarbonate (Boc₂O) (1.1 - 1.5 equiv) to the stirring solution.
- Reaction: Allow the reaction to stir at room temperature. Reaction times can vary from 1 to 12 hours.[6]
- Monitoring: Monitor the progress of the reaction by Thin Layer Chromatography (TLC) until the starting material is consumed.
- Work-up:
 - Upon completion, quench the reaction by adding saturated aqueous NaHCO₃ solution or water.[6][7]
 - Transfer the mixture to a separatory funnel and extract the product with an organic solvent (e.g., Dichloromethane or Ethyl Acetate).
 - Combine the organic layers and wash with brine.
 - Dry the organic layer over anhydrous MgSO₄ or Na₂SO₄, filter, and concentrate under reduced pressure using a rotary evaporator to obtain the crude product.
- Purification: If necessary, purify the crude product by column chromatography on silica gel to yield the pure N-Boc protected **2-Azaspiro[4.5]decane** derivative.

Data Presentation

The efficiency of N-Boc protection is influenced by the specific substrate, solvent, and the use of a base or catalyst.[6] The following table summarizes typical reaction conditions reported for the Boc protection of various secondary amines, which are applicable to **2-Azaspiro[4.5]decane** derivatives.

| Substrate | Reagent (equiv) | Base/Catalyst (equiv) | Solvent | Time (h) | Temp. | Yield (%) | Reference |
|-----------------|----------------------------------|-----------------------|-----------------------|-----------|-------|----------------|-----------|
| Secondary Amine | (Boc) ₂ O (1.2) | Triethylamine (2.5) | Dichloromethane (DCM) | 4 | RT | Good-Excellent | [7] |
| Secondary Amine | (Boc) ₂ O (1.1 - 1.5) | DMAP (catalytic) | Tetrahydrofuran (THF) | ~12 | RT | Not Specified | [6] |
| Secondary Amine | (Boc) ₂ O (1.0 - 1.2) | None | Water-Acetone | Short | RT | Excellent | [5][6] |
| Secondary Amine | (Boc) ₂ O (1.0) | Sodium Hydroxide (aq) | Tetrahydrofuran (THF) | Overnight | RT | ~91 | [6] |
| Secondary Amine | (Boc) ₂ O (1.0) | Iodine (catalytic) | Solvent-free | Short | RT | Good-Excellent | [4] |

Note: Yields are highly dependent on the specific substrate and purification method.

Visualizations

Reaction Workflow and Mechanism

To aid in the conceptualization of the experimental process and the underlying chemical transformation, the following diagrams are provided.

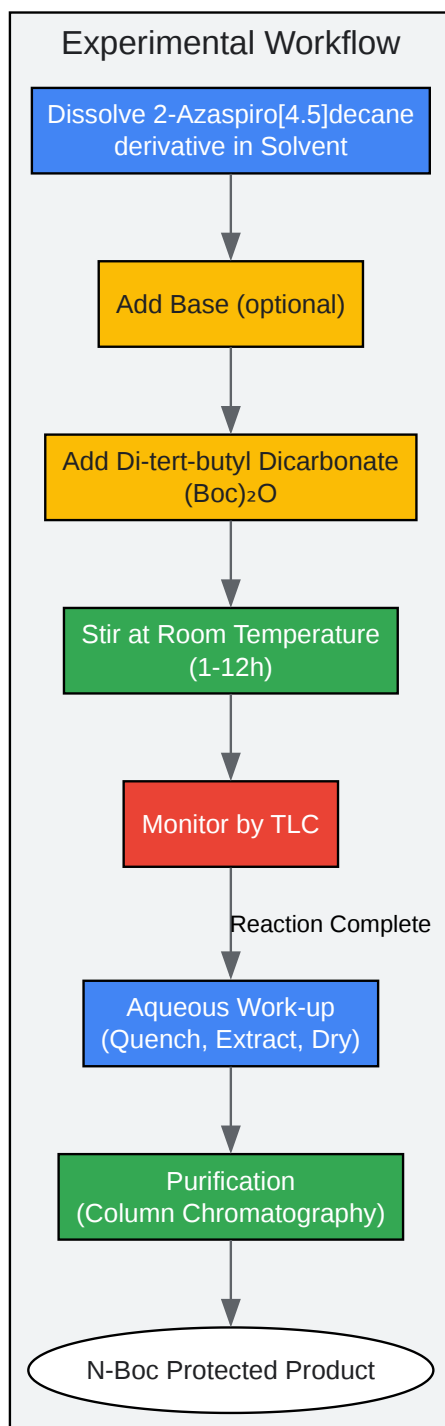

[Click to download full resolution via product page](#)

Caption: General experimental workflow for the N-Boc protection of amines.

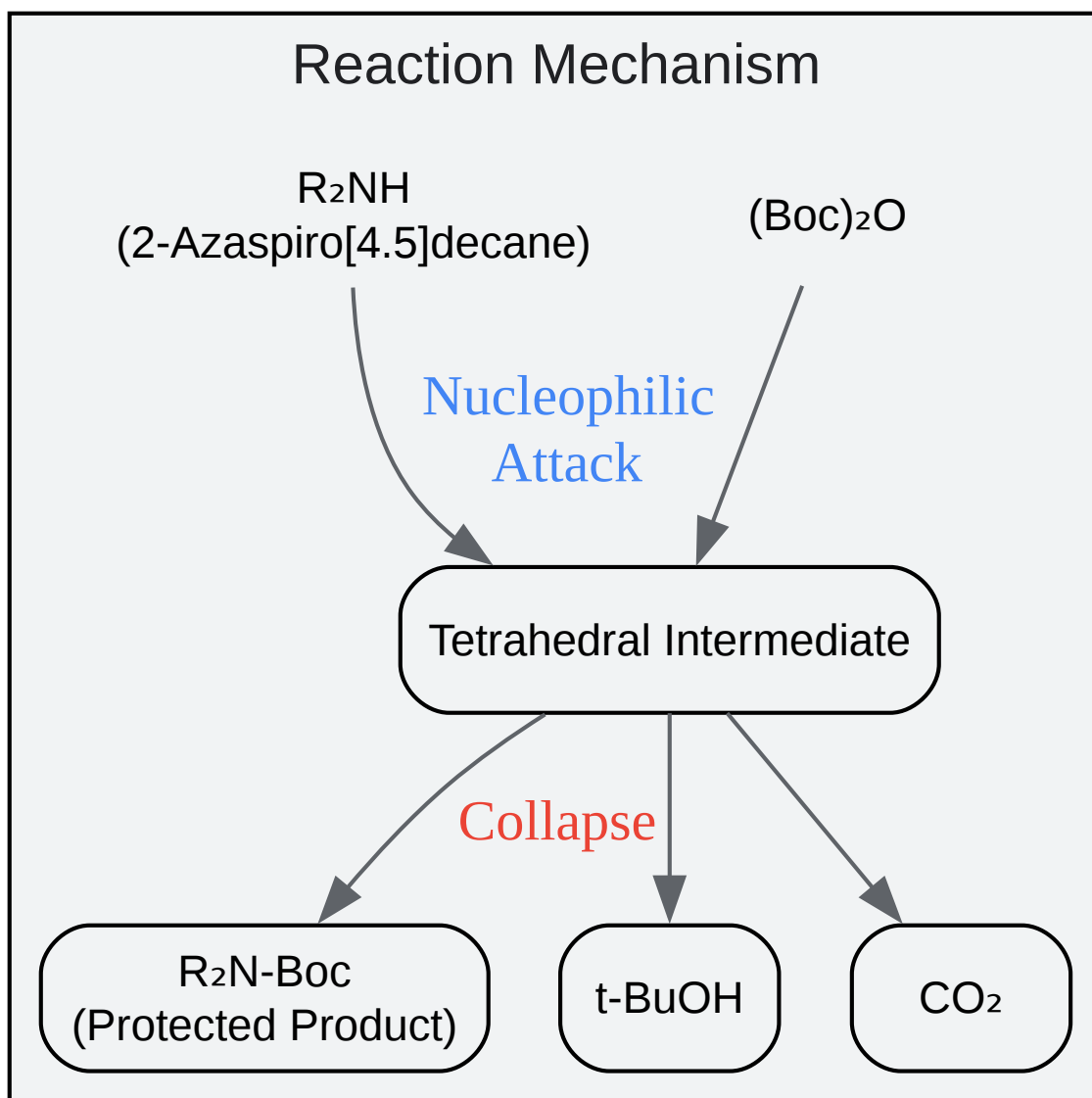

[Click to download full resolution via product page](#)

Caption: Simplified mechanism for the N-Boc protection of a secondary amine.

Need Custom Synthesis?

BenchChem offers custom synthesis for rare earth carbides and specific isotopic labeling.

Email: info@benchchem.com or [Request Quote Online](#).

References

- 1. benchchem.com [benchchem.com]
- 2. Discovery of novel 2,8-diazaspiro[4.5]decan-1-one derivatives as potent RIPK1 kinase inhibitors - PubMed [pubmed.ncbi.nlm.nih.gov]
- 3. Identification of a Novel 2,8-Diazaspiro[4.5]decan-1-one Derivative as a Potent and Selective Dual TYK2/JAK1 Inhibitor for the Treatment of Inflammatory Bowel Disease - PubMed [pubmed.ncbi.nlm.nih.gov]
- 4. Boc-Protected Amino Groups [organic-chemistry.org]
- 5. N-tert-Butoxycarbonylation of Structurally Diverse Amines and Sulfamides under Water-Mediated Catalyst-Free Conditions - PMC [pmc.ncbi.nlm.nih.gov]
- 6. benchchem.com [benchchem.com]
- 7. A One-Pot Selective Synthesis of N-Boc Protected Secondary Amines: Tandem Direct Reductive Amination/N-Boc Protection - PMC [pmc.ncbi.nlm.nih.gov]
- To cite this document: BenchChem. [Application Note: N-Boc Protection of 2-Azaspiro[4.5]decane Derivatives]. BenchChem, [2026]. [Online PDF]. Available at: [https://www.benchchem.com/product/b086298#n-boc-protection-of-2-azaspiro-4-5-decane-derivatives-protocol]

Disclaimer & Data Validity:

The information provided in this document is for Research Use Only (RUO) and is strictly not intended for diagnostic or therapeutic procedures. While BenchChem strives to provide accurate protocols, we make no warranties, express or implied, regarding the fitness of this product for every specific experimental setup.

Technical Support: The protocols provided are for reference purposes. Unsure if this reagent suits your experiment? [[Contact our Ph.D. Support Team for a compatibility check](#)]

Need Industrial/Bulk Grade? [Request Custom Synthesis Quote](#)

BenchChem

Our mission is to be the trusted global source of essential and advanced chemicals, empowering scientists and researchers to drive progress in science and industry.

Contact

Address: 3281 E Guasti Rd
Ontario, CA 91761, United States
Phone: (601) 213-4426
Email: info@benchchem.com