

Aminoguanidine Sulfate and Nitric Oxide Synthase: A Technical Guide to Their Interaction

Author: BenchChem Technical Support Team. **Date:** December 2025

Compound of Interest

Compound Name: *Aminoguanidine sulfate*

Cat. No.: *B086207*

[Get Quote](#)

For Researchers, Scientists, and Drug Development Professionals

This technical guide provides an in-depth exploration of the interaction between **aminoguanidine sulfate** and nitric oxide synthase (NOS). Overproduction of nitric oxide (NO) by the inducible isoform of nitric oxide synthase (iNOS) is implicated in the pathophysiology of various inflammatory diseases and diabetic complications.[1] Aminoguanidine has been identified as a selective inhibitor of iNOS, making it a valuable tool for research and a potential therapeutic agent.[2][3] This document details the mechanism of action, quantitative inhibition data, experimental protocols for assessing its activity, and the relevant signaling pathways.

Core Interaction: Selective Inhibition of iNOS

Aminoguanidine is a nucleophilic hydrazine compound that acts as a selective, mechanism-based inactivator of inducible nitric oxide synthase (iNOS).[4][5] Its selectivity for iNOS over the constitutive isoforms, endothelial NOS (eNOS) and neuronal NOS (nNOS), is a key feature of its pharmacological profile.[1][2] Studies have shown that aminoguanidine is significantly more potent in inhibiting iNOS, with some reports indicating it is 10 to 100-fold less potent as an inhibitor of the constitutive isoforms.[1] This selectivity is crucial for therapeutic applications, as constitutive NOS isoforms are responsible for essential physiological functions.

The mechanism of inactivation involves aminoguanidine acting as a substrate for the enzyme, and during the catalytic turnover, it inactivates the enzyme.[6] This inactivation is time- and concentration-dependent and requires the presence of cofactors necessary for NOS activity.[5] The inactivation of nNOS by aminoguanidine involves alteration of the prosthetic heme group.

[7] In contrast, the inactivation of iNOS by aminoguanidine does not appear to involve heme destruction but rather proceeds through covalent modification of the iNOS protein and the heme residue while maintaining the integrity of the porphyrin ring.[8]

Quantitative Inhibition Data

The inhibitory potency of aminoguanidine against the different NOS isoforms has been quantified in various studies. The following table summarizes key quantitative data, including IC50 and Ki values. It is important to note that these values can vary depending on the experimental conditions, such as substrate concentration and the source of the enzyme.

NOS Isoform	Parameter	Value	Species/Cell Type	Reference
iNOS	IC50	2.1 μ M	Mouse	[9]
Ki	16 μ M	Murine Macrophage	[5]	
nNOS	Ki	0.83 mM	GH3 Pituitary cNOS	[5]
eNOS	-	Millimolar range inhibition	Endothelial cNOS	[5]
iNOS vs. nNOS/eNOS	Selectivity	10 to 100-fold less potent on constitutive isoforms	-	[1]
iNOS vs. nNOS/eNOS	Selectivity	Over 50-fold more effective on iNOS	-	[2]

Experimental Protocols

In Vitro Nitric Oxide Synthase Inhibition Assay

This protocol outlines a general method for determining the inhibitory effect of aminoguanidine on NOS activity by measuring the conversion of L-arginine to L-citrulline.

1. Enzyme Preparation:

- Recombinant human iNOS, nNOS, or eNOS can be used. Alternatively, lysates from cells or tissues known to express the specific isoform can be prepared. For example, iNOS can be induced in RAW 264.7 macrophages by stimulation with lipopolysaccharide (LPS) and interferon-gamma.[9]

2. Reaction Mixture Preparation:

- Prepare a reaction buffer (e.g., 50 mM HEPES, pH 7.4) containing the following components (final concentrations):
 - 1 mM NADPH
 - 10 μ M FAD
 - 10 μ M FMN
 - 10 μ M Tetrahydrobiopterin (BH4)
 - 1 mM CaCl₂ (for constitutive isoforms)
 - 10 μ g/ml Calmodulin (for constitutive isoforms)
 - L-[14C]arginine (specific activity adjusted to desired final concentration, e.g., 10-100 μ M)
 - Varying concentrations of **aminoguanidine sulfate** or vehicle control.

3. Initiation of Reaction:

- Pre-incubate the enzyme preparation with the reaction mixture containing all components except L-[14C]arginine for 5 minutes at 37°C.
- Initiate the reaction by adding L-[14C]arginine.

4. Incubation:

- Incubate the reaction mixture for a defined period (e.g., 15-30 minutes) at 37°C. The incubation time should be within the linear range of the enzyme activity.

5. Termination of Reaction:

- Stop the reaction by adding a stop buffer (e.g., 100 mM HEPES, pH 5.5, containing 10 mM EDTA).

6. Separation of L-Citrulline:

- The product, L-[14C]citrulline, is separated from the unreacted substrate, L-[14C]arginine, using cation-exchange chromatography.
- Apply the reaction mixture to a column packed with Dowex AG50WX-8 resin (Na⁺ form).
- L-[14C]citrulline, being neutral, will pass through the column, while the positively charged L-[14C]arginine will be retained.
- Elute the L-[14C]citrulline with water or a suitable buffer.

7. Quantification:

- The amount of L-[14C]citrulline in the eluate is quantified using liquid scintillation counting.
- Enzyme activity is expressed as pmol of L-citrulline formed per minute per mg of protein.
- The inhibitory effect of aminoguanidine is calculated as the percentage of inhibition compared to the vehicle control. IC₅₀ values can be determined by plotting the percentage of inhibition against the logarithm of the aminoguanidine concentration.

Signaling Pathways and Logical Relationships

The interaction of aminoguanidine with the nitric oxide synthase pathway is central to its pharmacological effects. The following diagrams illustrate the mechanism of NOS activation and the point of intervention for aminoguanidine.

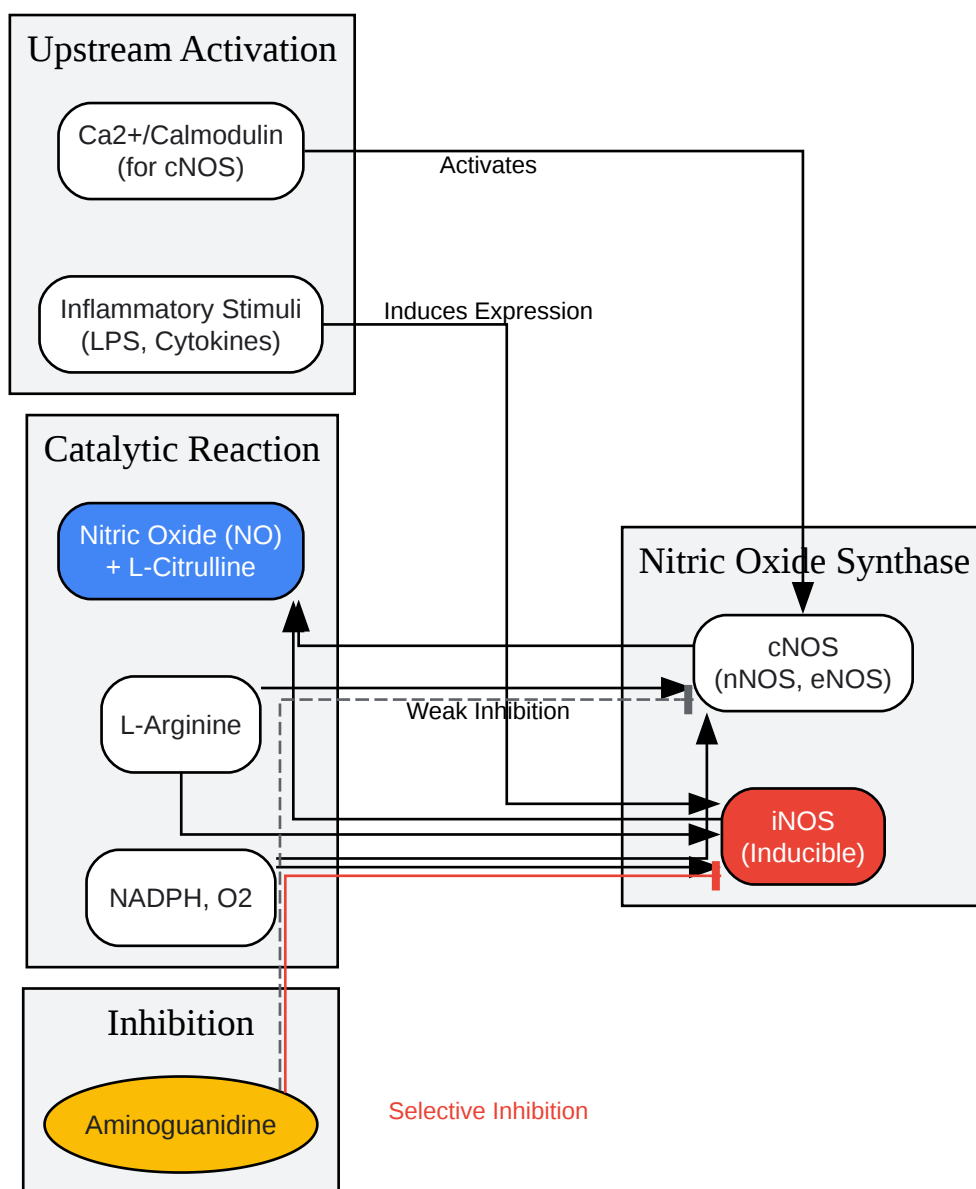

[Click to download full resolution via product page](#)

Caption: General overview of NOS activation and aminoguanidine inhibition.

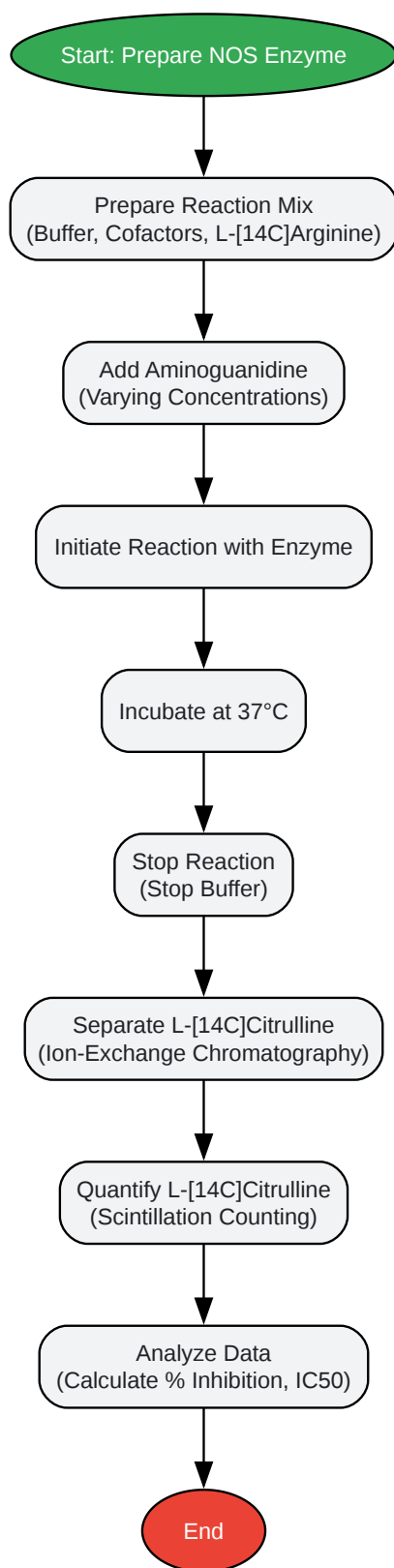

[Click to download full resolution via product page](#)

Caption: Workflow for in vitro NOS inhibition assay.

The selective inhibition of iNOS by aminoguanidine has been demonstrated in various experimental models, including isolated enzymes, cultured cells, and in vivo studies.[1][3] For instance, in endotoxin-treated rats, aminoguanidine effectively reduces the production of nitric oxide.[3] Furthermore, its therapeutic potential has been explored in conditions characterized by iNOS overexpression, such as autoimmune diabetes and experimental autoimmune encephalomyelitis.[2][4][10] In these models, aminoguanidine has been shown to delay disease onset and reduce severity.[2][4][10] These findings underscore the importance of the aminoguanidine-iNOS interaction as a target for drug development.

Need Custom Synthesis?

BenchChem offers custom synthesis for rare earth carbides and specific isotopic labeling.

Email: info@benchchem.com or [Request Quote Online](#).

References

- 1. Selective inhibition of the inducible nitric oxide synthase by aminoguanidine - PubMed [pubmed.ncbi.nlm.nih.gov]
- 2. The Use of Aminoguanidine, a Selective iNOS Inhibitor, to Evaluate the Role of Nitric Oxide in the Development of Autoimmune Diabetes - PubMed [pubmed.ncbi.nlm.nih.gov]
- 3. Aminoguanidine selectively inhibits inducible nitric oxide synthase - PubMed [pubmed.ncbi.nlm.nih.gov]
- 4. dm5migu4zj3pb.cloudfront.net [dm5migu4zj3pb.cloudfront.net]
- 5. Aminoguanidine is an isoform-selective, mechanism-based inactivator of nitric oxide synthase - PubMed [pubmed.ncbi.nlm.nih.gov]
- 6. Inactivation of nitric oxide synthase by substituted aminoguanidines and aminoisothioureas - PubMed [pubmed.ncbi.nlm.nih.gov]
- 7. Aminoguanidine-mediated inactivation and alteration of neuronal nitric-oxide synthase - PubMed [pubmed.ncbi.nlm.nih.gov]
- 8. Mechanism of inducible nitric oxide synthase inactivation by aminoguanidine and L-N⁶-(1-iminoethyl)lysine. [vivo.weill.cornell.edu]
- 9. Discovery of novel inhibitors of inducible nitric oxide synthase - PubMed [pubmed.ncbi.nlm.nih.gov]

- 10. Aminoguanidine, a selective inhibitor of the inducible nitric oxide synthase, has different effects on experimental allergic encephalomyelitis in the induction and progression phase - PubMed [pubmed.ncbi.nlm.nih.gov]
- To cite this document: BenchChem. [Aminoguanidine Sulfate and Nitric Oxide Synthase: A Technical Guide to Their Interaction]. BenchChem, [2025]. [Online PDF]. Available at: [https://www.benchchem.com/product/b086207#aminoguanidine-sulfate-and-nitric-oxide-synthase-interaction]

Disclaimer & Data Validity:

The information provided in this document is for Research Use Only (RUO) and is strictly not intended for diagnostic or therapeutic procedures. While BenchChem strives to provide accurate protocols, we make no warranties, express or implied, regarding the fitness of this product for every specific experimental setup.

Technical Support: The protocols provided are for reference purposes. Unsure if this reagent suits your experiment? [[Contact our Ph.D. Support Team for a compatibility check](#)]

Need Industrial/Bulk Grade? [Request Custom Synthesis Quote](#)

BenchChem

Our mission is to be the trusted global source of essential and advanced chemicals, empowering scientists and researchers to drive progress in science and industry.

Contact

Address: 3281 E Guasti Rd
Ontario, CA 91761, United States
Phone: (601) 213-4426
Email: info@benchchem.com