

A Comparative Guide to Polymer Synthesis and Characterization Using Dibutyl Xanthogen Disulfide

Author: BenchChem Technical Support Team. **Date:** May 2026

Compound of Interest

Compound Name: *Dibutyl xanthogen disulfide*

CAS No.: 105-77-1

Cat. No.: B086037

[Get Quote](#)

For Researchers, Scientists, and Drug Development Professionals

Introduction: Precision in Polymer Engineering with Dibutyl Xanthogen Disulfide

In the pursuit of advanced polymeric materials for applications ranging from sophisticated drug delivery systems to specialized industrial materials, the ability to control polymer architecture with precision is paramount. Reversible Addition-Fragmentation chain Transfer (RAFT) polymerization has emerged as a powerful and versatile technique for synthesizing polymers with well-defined molecular weights, low polydispersities, and complex architectures.[1][2] The choice of the RAFT agent, or chain transfer agent (CTA), is critical and dictates the range of monomers that can be effectively polymerized and the degree of control achievable.[2][3]

This guide provides an in-depth technical comparison of polymers synthesized using **Dibutyl Xanthogen Disulfide** (DBXD), a member of the xanthate class of RAFT agents. While much of the available literature focuses on its close analog, diisopropyl xanthogen disulfide (DIP), the

principles and performance characteristics are largely translatable to DBXD. We will objectively compare the performance of xanthogen disulfides with other common RAFT agents, supported by experimental data, and provide detailed protocols for synthesis and characterization. This guide is intended to equip researchers, scientists, and drug development professionals with the necessary insights to effectively utilize DBXD in their polymer synthesis endeavors.

The Mechanism of RAFT Polymerization with Dibutyl Xanthogen Disulfide

Dibutyl xanthogen disulfide is not the active chain transfer agent itself but rather a precursor that generates the active xanthate RAFT agent in situ.^[1] This process is initiated by the thermal decomposition of a standard radical initiator, such as Azobisisobutyronitrile (AIBN). The resulting radicals react with the DBXD to form the active S-(cyano)isopropyl xanthate, which then mediates the polymerization through the established RAFT mechanism.^[1] This mechanism involves a dynamic equilibrium between active (propagating radical) and dormant (thiocarbonylthio-capped) polymer chains, allowing for controlled chain growth.^{[1][3]}

The in situ generation of the active RAFT agent simplifies experimental procedures by eliminating the need for the synthesis and isolation of a dedicated CTA.^[4] This technique, a variant of Macromolecular Design via Interchange of Xanthates (MADIX), provides excellent control over the molecular weight and results in polymers with low polydispersity indices (PDI).^[4]

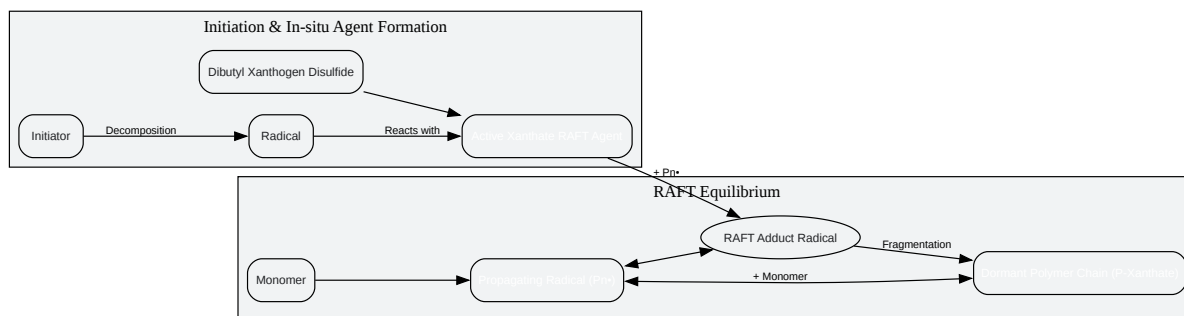

[Click to download full resolution via product page](#)

Caption: In-situ formation of the active RAFT agent from **Dibutyl Xanthogen Disulfide** and the subsequent RAFT polymerization cycle.

Performance Comparison of Dibutyl Xanthogen Disulfide with Alternative RAFT Agents

The effectiveness of a RAFT agent is highly dependent on the nature of the monomer being polymerized. Monomers are broadly classified as "More Activated Monomers" (MAMs), such as styrenes and acrylates, which form relatively stable propagating radicals, and "Less Activated Monomers" (LAMs), like vinyl acetate and N-vinylpyrrolidone, which form highly reactive, less stable propagating radicals.[2][3]

Xanthates, including DBXD, are generally considered less active RAFT agents.[2] This characteristic makes them exceptionally well-suited for controlling the polymerization of LAMs. [2] For MAMs, their control is often less effective, leading to broader molecular weight distributions.[2] In contrast, trithiocarbonates and dithiobenzoates are more active RAFT agents and are generally preferred for the polymerization of MAMs.[3]

The following tables summarize the expected performance of xanthogen disulfides (represented by the well-studied diisopropyl xanthogen disulfide) in comparison to other common RAFT agents for different monomer types.

Table 1: Performance Comparison for Less Activated Monomers (e.g., Vinyl Acetate)

RAFT Agent	Typical Mn (g/mol)	Typical PDI	Monomer Conversion (%)	Notes
Xanthogen Disulfide	High	< 1.3	High	Excellent control, well-suited for vinyl acetate.[2]
Trithiocarbonate	Low to Moderate	> 1.5	Low	Generally inhibit or poorly control the polymerization. [2]
Dithiobenzoate	Low	> 1.8	Very Low	Inhibit the polymerization of vinyl acetate.[2]

Table 2: Performance Comparison for More Activated Monomers (e.g., Styrene)

RAFT Agent	Typical Mn (g/mol)	Typical PDI	Monomer Conversion (%)	Notes
Xanthogen Disulfide	Moderate to High	> 1.5	Moderate	Generally poor control for styrene.[2]
Trithiocarbonate	High	< 1.3	High	Good control, versatile for various styrenic monomers.[2]
Dithiobenzoate	High	< 1.2	High	Excellent control, but potential for retardation.[2]

Table 3: Performance Comparison for More Activated Monomers (e.g., Methacrylates)

RAFT Agent	Typical Mn (g/mol)	Typical PDI	Monomer Conversion (%)	Notes
Xanthogen Disulfide	Moderate	> 1.5	Moderate	Not ideal for methacrylates, poor control.[2]
Trithiocarbonate	High	< 1.3	High	Effective control, suitable for a range of methacrylates.[2]
Dithiobenzoate	High	< 1.2	High	Very good control, often the preferred choice. [2]

Experimental Protocols

The following protocols are provided as a guide for the synthesis and characterization of polymers using a xanthogen disulfide precursor. These are based on established procedures for the closely related diisopropyl xanthogen disulfide and should be optimized for specific experimental setups and desired polymer characteristics.

Protocol 1: RAFT Polymerization of N-vinylpyrrolidone (NVP)

This protocol describes the synthesis of poly(N-vinylpyrrolidone) (PNVP), a biocompatible polymer with significant applications in the pharmaceutical and biomedical fields.[4]

Materials:

- N-vinylpyrrolidone (NVP), inhibitor removed
- **Dibutyl xanthogen disulfide** (DBXD)
- Azobisisobutyronitrile (AIBN)
- Anhydrous 1,4-dioxane
- Schlenk flask, magnetic stirrer, rubber septum
- Nitrogen or Argon source
- Oil bath

Procedure:

- **Reactant Preparation:** In a 50 mL Schlenk flask, combine NVP (e.g., 5.0 g, 45 mmol), **Dibutyl xanthogen disulfide** (e.g., 120 mg, 0.45 mmol), and AIBN (e.g., 14.8 mg, 0.09 mmol).[1]
- **Solvent Addition:** Add anhydrous 1,4-dioxane (e.g., 10 mL) to the flask.[1]
- **Degassing:** Seal the flask with a rubber septum and perform three freeze-pump-thaw cycles to remove dissolved oxygen.[1]

- Initiation: Place the flask in a preheated oil bath at 60-70°C and begin stirring.[\[1\]](#)
- Polymerization: Allow the reaction to proceed for the desired time (e.g., 4-24 hours). Samples can be taken periodically via a degassed syringe to monitor conversion.[\[1\]](#)
- Termination: To stop the polymerization, remove the flask from the oil bath and expose the solution to air. The solution can be cooled in an ice bath.[\[1\]](#)

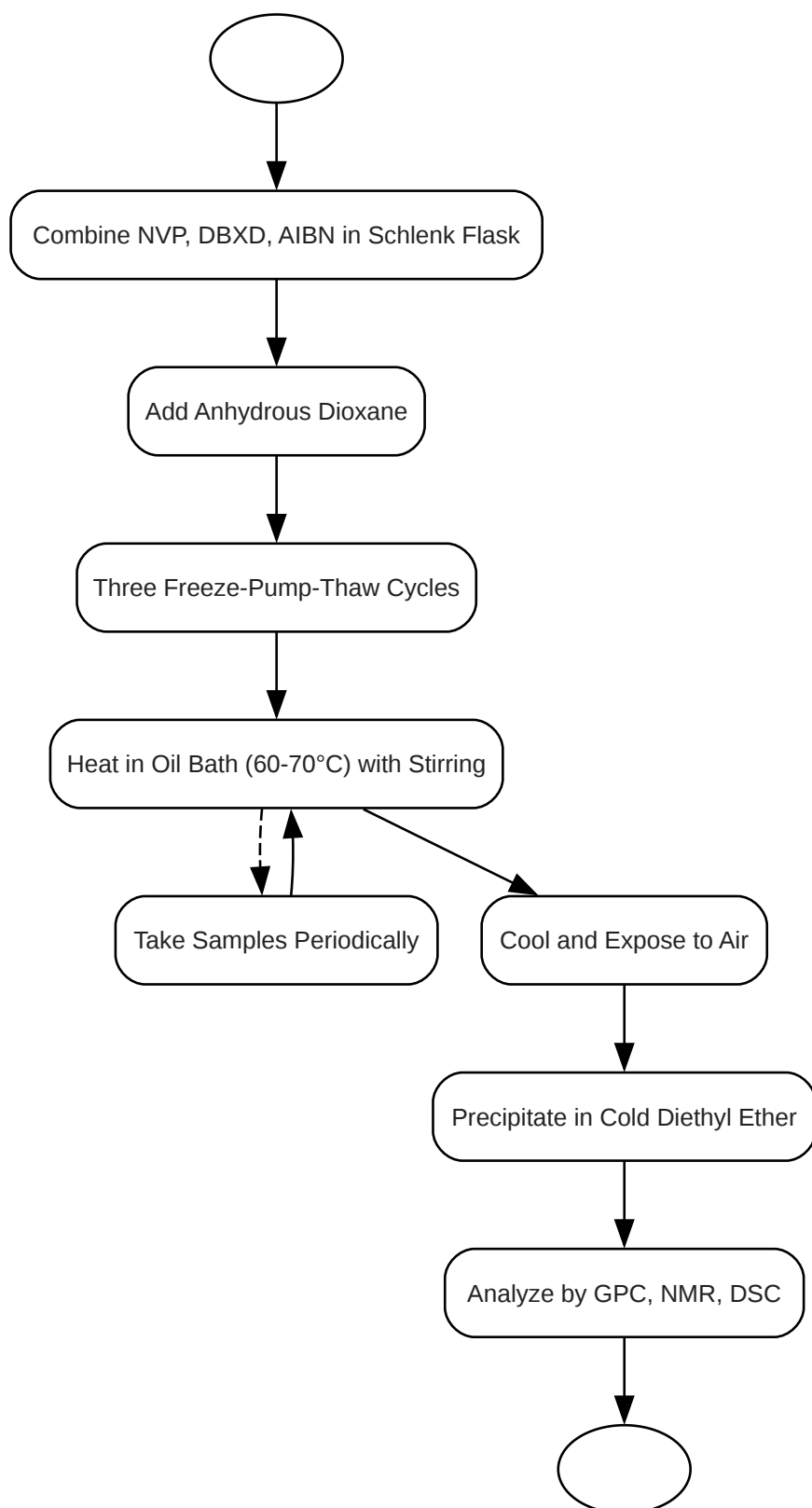

[Click to download full resolution via product page](#)

Caption: Workflow for a typical RAFT polymerization experiment using **Dibutyl Xanthogen Disulfide**.

Protocol 2: Polymer Purification

Materials:

- Polymer solution from Protocol 1
- Cold diethyl ether
- Centrifuge and tubes or filtration apparatus
- Vacuum oven

Procedure:

- **Precipitation:** Slowly pour the polymer solution from the reaction flask into a beaker containing a large excess of cold diethyl ether (e.g., 200 mL) while stirring vigorously. The polymer will precipitate as a solid.[\[1\]](#)
- **Isolation:** Isolate the polymer by either centrifugation or vacuum filtration.[\[1\]](#)
- **Washing:** Wash the collected polymer with fresh cold diethyl ether two more times to ensure the removal of unreacted monomer and initiator.[\[1\]](#)
- **Drying:** Dry the purified polymer in a vacuum oven at a moderate temperature (e.g., 40°C) overnight until a constant weight is achieved.[\[1\]](#)

Protocol 3: Characterization by Gel Permeation Chromatography (GPC/SEC)

GPC/SEC is used to determine the number-average molecular weight (M_n), weight-average molecular weight (M_w), and the polydispersity index ($PDI = M_w/M_n$) of the synthesized polymer.

Methodology:

- Mobile Phase: Tetrahydrofuran (THF) or Dimethylformamide (DMF) with 0.05 M LiBr, depending on polymer solubility.[1]
- Columns: A set of polystyrene-divinylbenzene columns.[1]
- Flow Rate: 1.0 mL/min.[1]
- Temperature: 40°C.[1]
- Detection: Differential Refractive Index (RI) detector.[1]
- Calibration: Use narrow polydispersity polystyrene or poly(methyl methacrylate) standards to generate a calibration curve.[1]
- Sample Preparation: Dissolve the dried polymer in the mobile phase at a concentration of approximately 1-2 mg/mL. Filter the solution through a 0.22 μm syringe filter before injection.
[1]

Protocol 4: Characterization by ^1H NMR Spectroscopy

^1H NMR spectroscopy is used to confirm the polymer structure and to determine monomer conversion.

Methodology:

- Solvent: Deuterated chloroform (CDCl_3) or deuterated water (D_2O).[1]
- Sample Preparation: Dissolve 5-10 mg of the purified polymer in ~ 0.7 mL of the deuterated solvent. For conversion analysis, use a sample taken directly from the reaction mixture.[1]
- Analysis:
 - Polymer Structure: Identify the broad peaks corresponding to the polymer backbone protons.[1]
 - Monomer Conversion: Compare the integration of the vinyl proton peaks of the monomer to the integration of the polymer backbone peaks. The disappearance or reduction of the monomer peaks indicates polymerization.[1]

Protocol 5: Characterization by Differential Scanning Calorimetry (DSC)

DSC is used to measure thermal transitions, most notably the glass transition temperature (T_g), which provides insight into the polymer's physical state.

Methodology:

- Sample Preparation: Accurately weigh 5-10 mg of the dry polymer into an aluminum DSC pan and seal it.[1]
- Heating/Cooling Cycle:
 - Heat the sample from room temperature to a temperature well above the expected T_g at a rate of $10^\circ\text{C}/\text{min}$ to erase the polymer's thermal history.[1]
 - Cool the sample back down to room temperature at $10^\circ\text{C}/\text{min}$.[1]
 - Heat the sample a second time at $10^\circ\text{C}/\text{min}$.[1]
- Analysis: Determine the glass transition temperature (T_g) from the inflection point in the heat flow curve of the second heating scan.[1]

Applications in Drug Development

The precise control over polymer characteristics afforded by RAFT polymerization using agents like DBXD is critical in drug development.[1] Polymer properties such as molecular weight and purity directly impact drug loading, release kinetics, and biocompatibility.[1] Polymers synthesized from LAMs, such as PNVP, are of significant interest in the biomedical and pharmaceutical fields due to their biocompatibility and solubility in both aqueous and organic media.[4]

The ability to synthesize well-defined block copolymers using RAFT allows for the creation of amphiphilic structures that can self-assemble into micelles or vesicles. These nanostructures can encapsulate hydrophobic drugs, enhancing their solubility and enabling targeted delivery.[5] Furthermore, the end-functionality inherent to RAFT-synthesized polymers allows for the straightforward conjugation of targeting ligands or therapeutic agents. While the potential

toxicity of the thiocarbonylthio end-groups has been a consideration, studies suggest that for many applications, the concentrations used are below the toxicity threshold, and these end-groups can be readily removed if necessary.[6]

Conclusion

Dibutyl xanthogen disulfide stands out as a highly effective RAFT agent precursor for the controlled polymerization of less activated monomers. Its ability to generate the active RAFT agent in situ simplifies the experimental process, making it an accessible choice for researchers. For applications requiring well-defined polymers from monomers like N-vinylpyrrolidone and vinyl acetate, DBXD and other xanthogen disulfides offer superior control over molecular weight and polydispersity compared to more active RAFT agents. This level of precision is particularly advantageous in the field of drug development, where polymer architecture directly influences therapeutic efficacy. While further research is needed to fully delineate the performance of DBXD with a broader range of monomers and to establish a more extensive library of quantitative data, the existing evidence strongly supports its utility as a valuable tool in the synthesis of advanced polymeric materials.

References

- Synthesis of polystyrene-block-poly(vinyl acetate) via combined RAFT and click chemistry. ResearchGate. [\[Link\]](#)
- RAFT Polymerization of Vinyl Esters: Synthesis and Applications. ResearchGate. [\[Link\]](#)
- RAFT Polymerization of Vinyl Esters: Synthesis and Applications. MDPI. [\[Link\]](#)
- Bioapplications of RAFT Polymerization. ACS Publications. [\[Link\]](#)
- Biomedical applications of polymers derived by reversible addition - fragmentation chain-transfer (RAFT). PubMed. [\[Link\]](#)
- ¹H NMR spectra of (a) poly(N-vinylpyrrolidone)-block-poly(vinyl... ResearchGate. [\[Link\]](#)
- DSC, TGA and DTA data of the obtained polymers. ResearchGate. [\[Link\]](#)

- Block Copolymers of Poly(N-Vinyl Pyrrolidone) and Poly(Vinyl Esters) Bearing n-alkyl Side Groups via Reversible Addition-Fragmentation Chain-Transfer Polymerization: Synthesis, Characterization, and Thermal Properties. MDPI. [\[Link\]](#)
- Recent Advances in the Synthesis of Complex Macromolecular Architectures Based on Poly(N-vinyl pyrrolidone) and the RAFT Polymerization Technique. PubMed Central. [\[Link\]](#)
- ¹H NMR spectra of the PVP samples: undegraded and degraded at 753 K. ResearchGate. [\[Link\]](#)
- A guide to the synthesis of block copolymers using reversible-addition fragmentation chain transfer (RAFT) polymerization. RSC Publishing. [\[Link\]](#)
- Substituent Effects in Xanthate-Mediated Polymerization of Vinyl Acetate: Ab Initio Evidence for an Alternative Fragmentation Pathway. ResearchGate. [\[Link\]](#)
- ¹H NMR spectrum of vinyl PB (B in Table I). ResearchGate. [\[Link\]](#)
- RAFT-Polymerization of N-Vinyl Pyrrolidone and Methyl Methacrylate for Synthesis of Functional Co-Blockpolymer Binders for. Diva-portal.org. [\[Link\]](#)
- Synthesis of poly(vinyl acetate) block copolymers by successive RAFT and ATRP with a bromoxanthate iniferter. RSC Publishing. [\[Link\]](#)
- Differential Scanning Thermal Analysis in Polymeric Materials. AZoM.com. [\[Link\]](#)
- Characterization of Polymers using Differential Scanning Calorimetry (DSC). Eurofins. [\[Link\]](#)
- ¹H NMR spectrum of a mixture of NVP and its hydration products collected upon distillation in CDCl₃. ResearchGate. [\[Link\]](#)
- Synthesis of Poly(vinyl acetate) and Poly(vinyl alcohol) Containing Block Copolymers by Combination of Cobalt-Mediated Radical Polymerization and ATRP. ResearchGate. [\[Link\]](#)
- Investigation of Polymers with Differential Scanning Calorimetry. MIT OpenCourseWare. [\[Link\]](#)
- Thermal Analysis of Polymers. Part 3: DSC of Thermosets. Mettler Toledo. [\[Link\]](#)

- Biocompatible Polymer-Grafted TiO₂ Nanoparticle Sonosensitizers Prepared Using Phosphonic Acid-Functionalized RAFT Agent. MDPI. [\[Link\]](#)
- Synthesis of Well-Defined Poly(vinyl alcohol-co-vinyl acetate) Copolymers by Alcoholysis of Poly(vinyl acetate) Synthesized by Macromolecular Design via Interchange of Xanthate Polymerization, and Their Use as a Stabilizer in Emulsion (Co)polymerization of Vinyl Acetate. ResearchGate. [\[Link\]](#)

Need Custom Synthesis?

BenchChem offers custom synthesis for rare earth carbides and specific isotopic labeling.

Email: info@benchchem.com or [Request Quote Online](#).

Sources

- [1. pdf.benchchem.com \[pdf.benchchem.com\]](#)
- [2. pdf.benchchem.com \[pdf.benchchem.com\]](#)
- [3. pdf.benchchem.com \[pdf.benchchem.com\]](#)
- [4. pdf.benchchem.com \[pdf.benchchem.com\]](#)
- [5. researchgate.net \[researchgate.net\]](#)
- [6. Biomedical applications of polymers derived by reversible addition - fragmentation chain-transfer \(RAFT\) - PubMed \[pubmed.ncbi.nlm.nih.gov\]](#)
- To cite this document: BenchChem. [A Comparative Guide to Polymer Synthesis and Characterization Using Dibutyl Xanthogen Disulfide]. BenchChem, [2026]. [Online PDF]. Available at: [\[https://www.benchchem.com/product/b086037/docs#a-comparative-guide-to-polymer-synthesis-and-characterization-using-dibutyl-xanthogen-disulfide\]](https://www.benchchem.com/product/b086037/docs#a-comparative-guide-to-polymer-synthesis-and-characterization-using-dibutyl-xanthogen-disulfide)

Disclaimer & Data Validity:

The information provided in this document is for Research Use Only (RUO) and is strictly not intended for diagnostic or therapeutic procedures. While BenchChem strives to provide accurate protocols, we make no warranties, express or implied, regarding the fitness of this product for every specific experimental setup.

Technical Support: The protocols provided are for reference purposes. Unsure if this reagent suits your experiment?

Need Industrial/Bulk Grade? [Request Custom Synthesis Quote](#)

BenchChem

Our mission is to be the trusted global source of essential and advanced chemicals, empowering scientists and researchers to drive progress in science and industry.

Contact

Address: 3281 E Guasti Rd
Ontario, CA 91761, United States
Phone: (601) 213-4426
Email: info@benchchem.com

[Contact our Ph.D. Support Team for a compatibility check](#)