

# Williamson ether synthesis protocols for 3-(3-Chlorobenzoyloxy)pyrrolidine

**Author:** BenchChem Technical Support Team. **Date:** April 2026

## Compound of Interest

Compound Name: 3-(3-Chlorobenzoyloxy)pyrrolidine

Cat. No.: B8581838

[Get Quote](#)

Application Note: Optimized Synthesis of **3-(3-Chlorobenzoyloxy)pyrrolidine** via Williamson Etherification

## Abstract & Scope

This application note details the optimized protocols for the synthesis of **3-(3-Chlorobenzoyloxy)pyrrolidine**, a valuable scaffold in medicinal chemistry often found in GPCR ligands and kinase inhibitors. The synthesis hinges on the construction of the C–O ether bond via Williamson Ether Synthesis.<sup>[1][2][3][4]</sup>

Two distinct protocols are provided to address different scale and resource constraints:

- Method A (Standard): Sodium Hydride (NaH) in DMF (High yield, small-to-mid scale).
- Method B (Green/Scalable): Phase Transfer Catalysis (PTC) using Toluene/NaOH (Process-friendly).

Critical Pre-requisite: To prevent competing N-alkylation, the pyrrolidine nitrogen must be protected. This guide utilizes (3R)-1-Boc-3-pyrrolidinol (or the racemate) as the starting nucleophile.

## Strategic Analysis & Mechanism

The formation of the ether linkage involves the nucleophilic attack of a pyrrolidinyl alkoxide on 3-chlorobenzyl bromide.

- **Regioselectivity:** The N-Boc group renders the nitrogen non-nucleophilic, forcing reaction exclusively at the oxygen.
- **Reactivity:** 3-Chlorobenzyl bromide is a highly reactive electrophile (primary benzylic halide). Consequently, the reaction proceeds rapidly via an SN2 mechanism.[1]
- **Side Reactions:**
  - **Elimination:** Minimal, as benzylic halides do not undergo E2 elimination easily.
  - **Hydrolysis:**[5][6] Moisture will consume the benzylic halide to form the benzyl alcohol. Anhydrous conditions are critical for Method A.

## Visualizing the Reaction Pathway

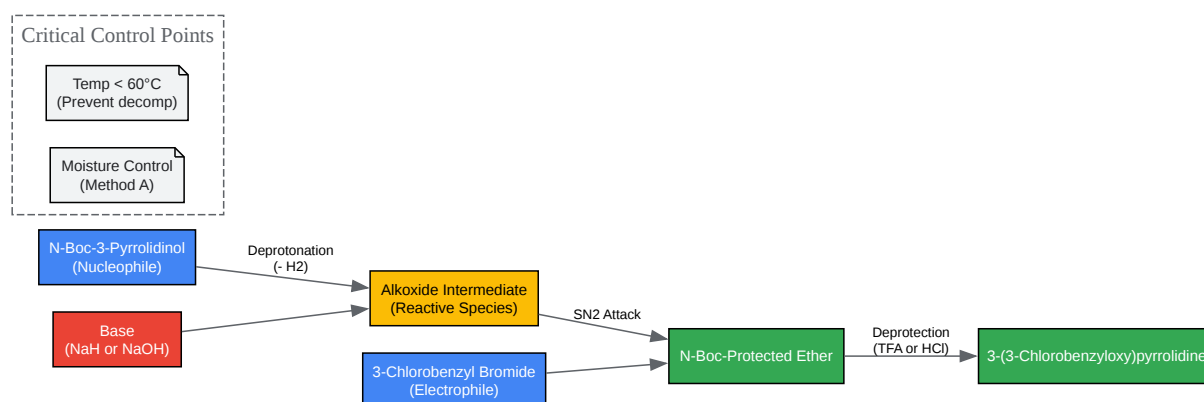

[Click to download full resolution via product page](#)

Figure 1: Reaction pathway from starting material to deprotected amine. Note the critical intermediate alkoxide formation.

## Safety Profile: 3-Chlorobenzyl Bromide[7][8]

Before proceeding, researchers must acknowledge the hazards of the electrophile.

Hazard Class	Description	Mitigation
Lachrymator	Causes severe eye irritation and tearing.	Handle only in a functioning fume hood.
Corrosive	Causes skin burns and eye damage (Skin Corr.[7][8] 1B).	Wear nitrile gloves, lab coat, and chemical splash goggles.
Inhalation	Destructive to mucous membranes.[9]	Avoid breathing vapors; keep vessels closed.

Reference: Fisher Scientific SDS [1]; Sigma-Aldrich SDS [2].

## Protocol A: Sodium Hydride (NaH) in DMF

Best for: Discovery chemistry, small scales (<10g), and maximizing yield.

### Reagents & Stoichiometry

- 1-Boc-3-pyrrolidinol: 1.0 equiv.
- Sodium Hydride (60% in oil): 1.2 equiv.
- 3-Chlorobenzyl bromide: 1.1 equiv.[9]
- DMF (Anhydrous): 0.2 M concentration relative to alcohol.

### Step-by-Step Procedure

- Setup: Flame-dry a 2-neck round-bottom flask equipped with a magnetic stir bar and nitrogen inlet.

- Base Suspension: Add NaH (60% dispersion) to the flask. (Optional: Wash NaH with dry hexane to remove oil if high purity is required, though usually unnecessary). Add anhydrous DMF and cool to 0 °C in an ice bath.
- Alkoxide Formation: Dissolve 1-Boc-3-pyrrolidinol in a minimal amount of DMF. Add this solution dropwise to the NaH suspension.
  - Observation: Hydrogen gas evolution will occur.[10]
  - Time: Stir at 0 °C for 30 minutes, then warm to Room Temperature (RT) for 30 minutes to ensure complete deprotonation.
- Alkylation: Cool the mixture back to 0 °C. Add 3-chlorobenzyl bromide dropwise (neat or in minimal DMF).
- Reaction: Remove ice bath and stir at RT for 4–6 hours.
  - Monitor: Check TLC (Hexane/EtOAc 3:1). The bromide spot should disappear.
- Quench: Cool to 0 °C. Carefully add water dropwise to quench excess NaH.
- Workup: Dilute with Ethyl Acetate (EtOAc). Wash organic layer with water (3x) to remove DMF, then brine (1x). Dry over Na<sub>2</sub>SO<sub>4</sub>, filter, and concentrate.
- Purification: Flash column chromatography (Silica gel, 0-30% EtOAc in Hexanes).

## Protocol B: Phase Transfer Catalysis (PTC)

Best for: Process chemistry, scale-up (>10g), and avoiding hazardous NaH.

### Reagents & Stoichiometry

- 1-Boc-3-pyrrolidinol: 1.0 equiv.
- 3-Chlorobenzyl bromide: 1.2 equiv.
- NaOH (50% aq. solution): 5.0 equiv.
- Tetrabutylammonium bromide (TBAB): 0.05 equiv (5 mol%).

- Toluene: 3-5 volumes (mL/g).

## Step-by-Step Procedure

- Reaction Mixture: In a round-bottom flask, combine 1-Boc-3-pyrrolidinol, 3-chlorobenzyl bromide, TBAB, and Toluene.
- Base Addition: Add 50% NaOH solution in one portion.
- Reaction: Heat the biphasic mixture to 50–60 °C with vigorous stirring (high RPM is critical for phase transfer).
  - Time: 4–12 hours.
- Workup: Cool to RT. Separate phases. Extract the aqueous layer once with Toluene.
- Wash: Wash combined organics with water and brine.<sup>[4][10]</sup>
- Concentration: Evaporate solvent to yield the crude oil. (Often sufficiently pure for deprotection without chromatography).

## Deprotection (Boc Removal)

To obtain the final target **3-(3-chlorobenzoyloxy)pyrrolidine**:

- Dissolve the intermediate in DCM (0.2 M).
- Add Trifluoroacetic acid (TFA) (10–20 equiv).
- Stir at RT for 2 hours.
- Concentrate in vacuo.
- Free Basing: Redissolve residue in DCM, wash with sat. NaHCO<sub>3</sub>, dry, and concentrate.

## Process Control & Analytics

### Decision Matrix: Method Selection

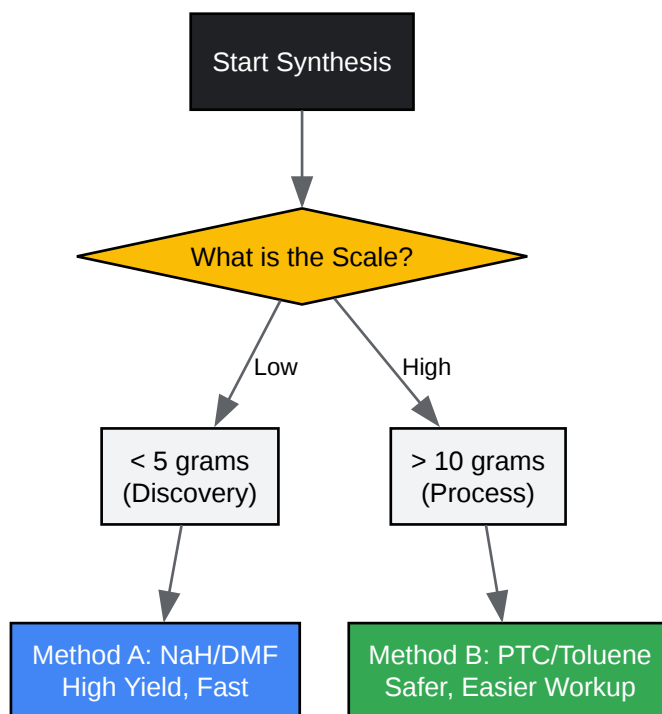

[Click to download full resolution via product page](#)

Figure 2: Decision matrix for selecting the appropriate synthesis protocol.

## Diagnostic Analytical Data (Expected)

- $^1\text{H}$  NMR ( $\text{CDCl}_3$ , 400 MHz):
  - Benzylic Protons:  $\delta$  4.50 (s, 2H) – Distinct singlet.
  - Ether Methine:  $\delta$  4.10–4.20 (m, 1H) – Shifted downfield by oxygen.
  - Aromatic:  $\delta$  7.15–7.40 (m, 4H) – Pattern characteristic of 3-substituted benzene.
  - Boc-Group (Intermediate):  $\delta$  1.45 (s, 9H).

## References

- Freedman, H. H., & Dubois, R. A. (1975).[11] An improved Williamson ether synthesis using phase transfer catalysis.[11] *Tetrahedron Letters*, 16(38), 3251-3254. [[Link](#)]
- Master Organic Chemistry. (2014).[1] The Williamson Ether Synthesis. Retrieved from [[Link](#)]

- Organic Chemistry Portal. Protective Groups: Boc. Retrieved from [[Link](#)]

### Need Custom Synthesis?

BenchChem offers custom synthesis for rare earth carbides and specific isotopic labeling.

Email: [info@benchchem.com](mailto:info@benchchem.com) or [Request Quote Online](#).

## Sources

- 1. [masterorganicchemistry.com](https://www.masterorganicchemistry.com) [[masterorganicchemistry.com](https://www.masterorganicchemistry.com)]
- 2. [Williamson ether synthesis - Wikipedia](https://en.wikipedia.org/wiki/Williamson_ether_synthesis) [[en.wikipedia.org](https://en.wikipedia.org)]
- 3. [scholarship.richmond.edu](https://scholarship.richmond.edu) [[scholarship.richmond.edu](https://scholarship.richmond.edu)]
- 4. [pdf.smolcule.com](https://pdf.smolcule.com) [[pdf.smolcule.com](https://pdf.smolcule.com)]
- 5. [ijirset.com](https://www.ijirset.com) [[ijirset.com](https://www.ijirset.com)]
- 6. [Progress in the Stereoselective Synthesis Methods of Pyrrolidine-Containing Drugs and Their Precursors](https://www.mdpi.com) [[mdpi.com](https://www.mdpi.com)]
- 7. [fishersci.com](https://www.fishersci.com) [[fishersci.com](https://www.fishersci.com)]
- 8. [3-Chlorobenzyl Bromide | 766-80-3 | TCI AMERICA](https://www.tcichemicals.com) [[tcichemicals.com](https://www.tcichemicals.com)]
- 9. [synquestlabs.com](https://www.synquestlabs.com) [[synquestlabs.com](https://www.synquestlabs.com)]
- 10. [pdf.benchchem.com](https://pdf.benchchem.com) [[pdf.benchchem.com](https://pdf.benchchem.com)]
- 11. [semanticscholar.org](https://www.semanticscholar.org) [[semanticscholar.org](https://www.semanticscholar.org)]
- To cite this document: BenchChem. [Williamson ether synthesis protocols for 3-(3-Chlorobenzoyloxy)pyrrolidine]. BenchChem, [2026]. [Online PDF]. Available at: [<https://www.benchchem.com/product/b8581838/docs#williamson-ether-synthesis-protocols-for-3-3-chlorobenzoyloxy-pyrrolidine>]

---

### Disclaimer & Data Validity:

The information provided in this document is for Research Use Only (RUO) and is strictly not intended for diagnostic or therapeutic procedures. While BenchChem strives to provide accurate protocols, we make no warranties, express or implied, regarding the fitness of this product for every specific experimental setup.

**Technical Support:** The protocols provided are for reference purposes. Unsure if this reagent suits your experiment?

**Need Industrial/Bulk Grade?** [Request Custom Synthesis Quote](#)

## BenchChem

Our mission is to be the trusted global source of essential and advanced chemicals, empowering scientists and researchers to drive progress in science and industry.

### Contact

Address: 3281 E Guasti Rd  
Ontario, CA 91761, United States  
Phone: (601) 213-4426  
Email: [info@benchchem.com](mailto:info@benchchem.com)

[Contact our Ph.D. Support Team for a compatibility check](#)